

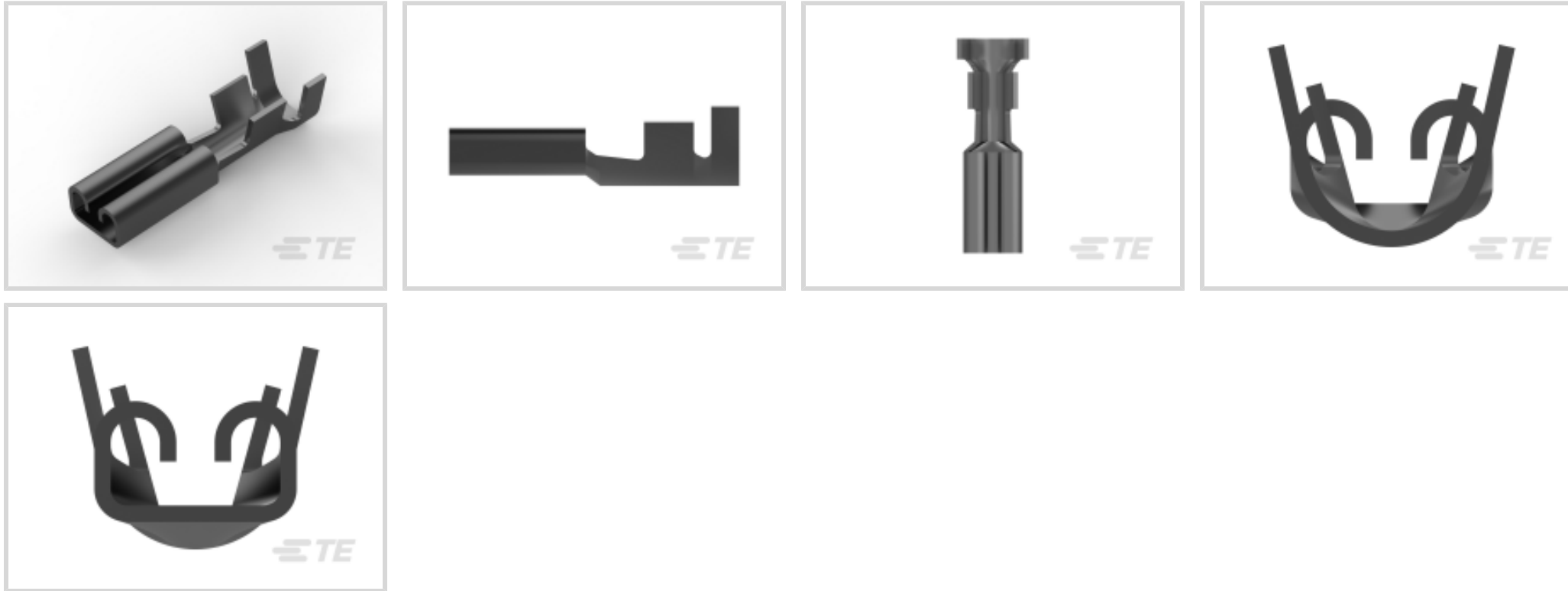

Terminals & Splices > Quick Disconnects



Quick Disconnect Terminal Type: **Receptacle**

Wire Size: .5 – 1.5 mm²

Mating Tab Width: 2.8 mm [.11 in]

Mating Tab Thickness: .8 mm [.032 in]

Features

Configuration Features

Compatible With Wire & Cable Type	Discrete Wire
Connection Capacity	Single

Contact Features

Quick Disconnect Terminal Type	Receptacle
Mating Tab Width	2.8 mm [.11 in]
Mating Tab Thickness	.8 mm [.032 in]
Terminal Orientation	Straight
Contact Base Material	Brass
Terminal Plating Material	Tin
Crimp Type	F-Crimp
Barrel Type	Open

Termination Features

Product Terminates To	Wire & Cable
-----------------------	--------------

Mechanical Attachment

--	--



Wire Insulation Support	With
-------------------------	------

Mating Retention Type	Dimple
-----------------------	--------

Dimensions

Product Length	13.4 mm [.527 in]
----------------	-------------------

Compatible Insulation Diameter Range	1.5 – 2.8 mm [.059 – .11 in]
--------------------------------------	------------------------------

Terminal Material Thickness	.3 mm [.012 in]
-----------------------------	-----------------

Wire Size	.5 – 1.5 mm ²
-----------	--------------------------

Usage Conditions

Insulation Option	Uninsulated
-------------------	-------------

Operating Temperature Range	-40 – 110 °C [-40 – 230 °F]
-----------------------------	-----------------------------

Industry Standards

Compatible With Agency/Standards Products	CSA, UL
---	---------

Packaging Features

Packaging Quantity	15000
--------------------	-------

Packaging Method	Strip/Reel
------------------	------------

Product Compliance

[For compliance documentation, visit the product page on TE.com>](#)

EU RoHS Directive 2011/65/EU	Compliant
------------------------------	-----------

EU ELV Directive 2000/53/EC	Compliant
-----------------------------	-----------

China RoHS 2 Directive MIIT Order No 32, 2016	No Restricted Materials Above Threshold
---	---

EU REACH Regulation (EC) No. 1907/2006	Current ECHA Candidate List: JAN 2025 (247) Candidate List Declared Against: JAN 2025 (247) Does not contain REACH SVHC
--	---

Halogen Content	Low Halogen - Br, Cl, F, I < 900 ppm per homogenous material. Also BFR/CFR/PVC Free
-----------------	---

Solder Process Capability	Not applicable for solder process capability
---------------------------	--

Product Compliance Disclaimer

This information is provided based on reasonable inquiry of our suppliers and represents our current actual knowledge based on the information they provided. This information is subject to change. The part numbers that TE has identified as EU RoHS compliant have a maximum concentration of 0.1% by weight in homogenous materials for lead, hexavalent chromium, mercury, PBB, PBDE, DBP, BBP, DEHP, DIBP, and 0.01% for cadmium, or qualify for an exemption to these limits as defined in the Annexes of Directive 2011/65/EU (RoHS2). Finished electrical and electronic equipment products will be CE marked as required by Directive 2011/65/EU. Components may not be CE marked. Additionally, the part



numbers that TE has identified as EU ELV compliant have a maximum concentration of 0.1% by weight in homogenous materials for lead, hexavalent chromium, and mercury, and 0.01% for cadmium, or qualify for an exemption to these limits as defined in the Annexes of Directive 2000/53/EC (ELV). Regarding the REACH Regulation, the information TE provides on SVHC in articles for this part number is based on the latest European Chemicals Agency (ECHA) 'Guidance on requirements for substances in articles' posted at this URL: <https://echa.europa.eu/guidance-documents/guidance-on-reach>

Compatible Parts



TE Part # 2150457-2
OCEAN_2.0_Applicator-E-080F140F-REA



TE Part # 7-2150457-7
OCEAN_2.0_SPARE_PART_KIT-080F140F



TE Part # 2150457-1
OCEAN_2.0_Applicator-E-080F140F-REM

Also in the Series | FASTON 110

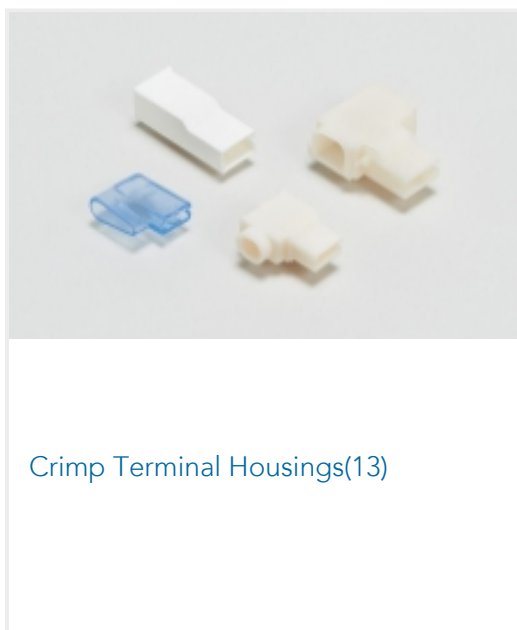

Crimp Terminal Housings(13)

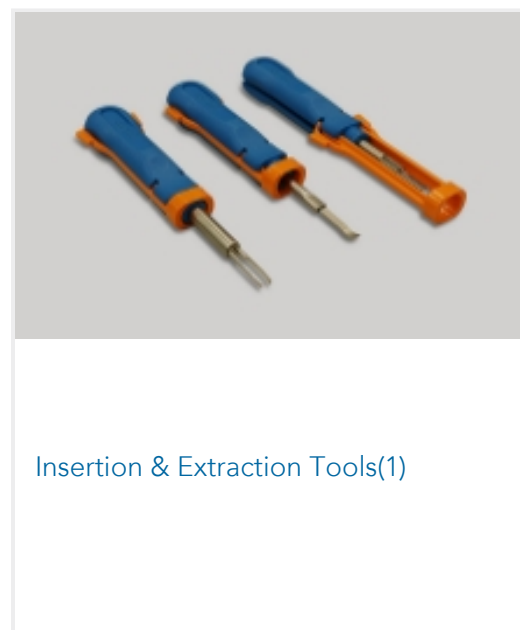

Insertion & Extraction Tools(1)



PCB Terminals(22)

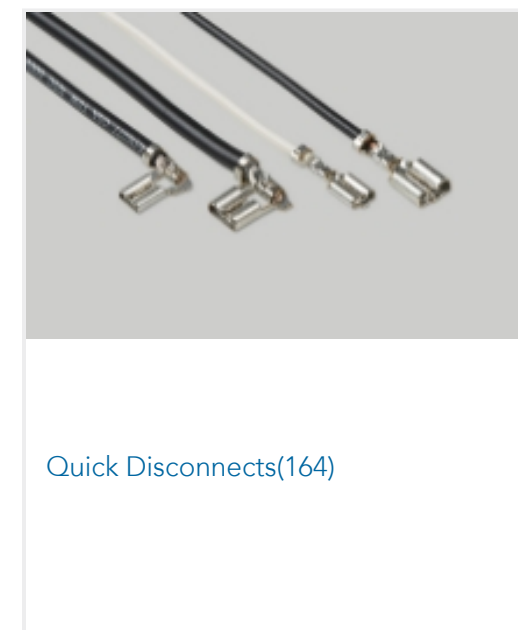

Quick Disconnects(164)

Customers Also Bought



TE Part #1-967621-4
JUN-POW-TIM GEH 9P



TE Part #1217138-1
110 FASTON,FLAG,REC.,22-18 AWG, PTBR



TE Part #2377780-2
36POS,AMP MCP 1.5K,REC HSG ASSY, UNSLD



TE Part #3870043009
44A1111-24-9-9



TE Part #5-1418760-3
MCON 1.2 LL TAB STC AG



TE Part #9-2334942-1
HD MATEnet COVER FOR SWS, GRP D



TE Part #1-480435-0
FASTON 187 REC HSG NYLON NAT



TE Part #174204-1
250 FASTON HSG.,REC.,6 POS, NATURAL

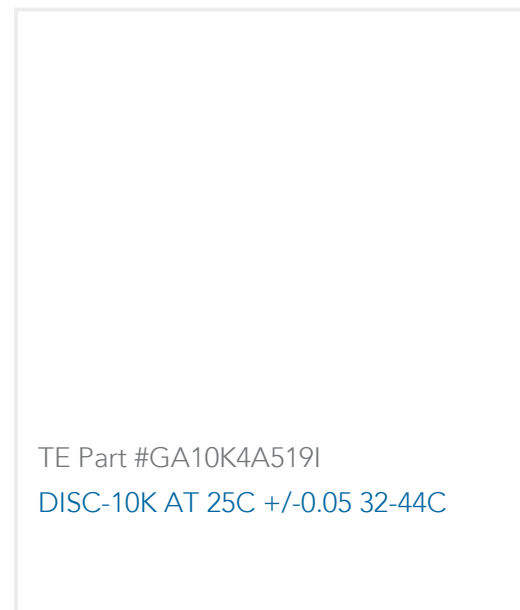

Documents

Product Drawings

[110 FASTON,REC.,20-16 AWG,TPBR](#)

English

CAD Files

Customer View Model

[ENG_CVM_CVM_180423-2_AG.2d_dxf.zip](#)

English

[3D PDF](#)

3D

Customer View Model

[ENG_CVM_CVM_180423-2_AG.3d_igs.zip](#)

English

Customer View Model

[ENG_CVM_CVM_180423-2_AG.3d_stp.zip](#)

English

By downloading the CAD file I accept and agree to the [Terms and Conditions](#) of use.

Datasheets & Catalog Pages

[1654742_HOUSEHOLD_APPLIANCES_RAST5](#)

English

Product Specifications

[Application Specification](#)

English