

## MCX Jack Right Angle Commercial Grade Connector Solder Attachment Thru Hole PCB

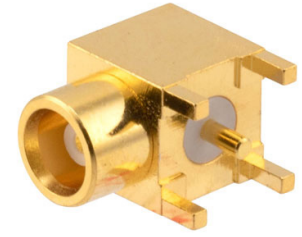

### PE51698

#### Configuration

- MCX Jack Connector
- 50 Ohms
- Right Angle Body Geometry
- Connector Interface Types: Thru Hole
- Commercial Grade Design

#### Features

- Max. Operating Frequency 6 GHz
- Good VSWR of 1.3:1
- Gold Plated Beryllium copper Contact

#### Applications

- General Purpose Test
- PCB Applications

#### Description

Pasternack's PE51698 Right Angle, MCX, Commercial Grade, connector with solder attachment for Thru Hole PCB is part of our full line of RF components available for same-day shipping. Our MCX jack connector operates up to a maximum frequency of 6 GHz and offers good VSWR of 1.3:1. Its right angle body geometry allows for easier connections in tight spaces.

Our MCX jack right angle connector PE51698 datasheet specifications and drawing with dimensions are shown below in this PDF. Pasternack's broad catalog of RF, microwave and millimeter wave connectors allows designers to configure and customize their signal connections however they like. Whether the need is to provide an I/O for a board design, or simply create a custom cable assembly configuration, Pasternack has the right connector for the job. Pasternack can also expertly build your custom cable assemblies for you and ship same-day.

#### Electrical Specifications

Description	Minimum	Typical	Maximum	Units
Frequency Range	DC		6	GHz
VSWR			1.3:1	
Insertion Loss			0.4	dB
Impedance		50		Ohms

#### Mechanical Specifications

##### Size

Length	0.37 in [9.4 mm]
Width	0.32 in [8.13 mm]
Height	0.16 in [4.06 mm]
Weight	0.02 lbs [9.07 g]

#### Material Specifications

Description	Material	Plating
Contact	Beryllium copper	Gold
Insulation	PTFE	
Body	Brass	Gold

## MCX Jack Right Angle Commercial Grade Connector Solder Attachment Thru Hole PCB

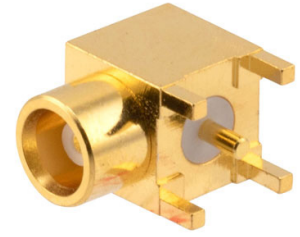

### PE51698

---

#### Environmental Specifications

Temperature

**Compliance Certifications** (see [product page](#) for current document)

#### Plotted and Other Data

Notes:

MCX Jack Right Angle Commercial Grade Connector Solder Attachment Thru Hole PCB from Pasternack Enterprises has same day shipment for domestic and International orders. Our RF, microwave and millimeter wave products maintain a 99.4% availability and are part of the broadest selection in the industry.

Click the following link (or enter part number in "SEARCH" on website) to obtain additional part information including price, inventory and certifications: [MCX Jack Right Angle Commercial Grade Connector Solder Attachment Thru Hole PCB PE51698](#)

URL: <https://www.pasternack.com/mcx-jack-thru-hole-pcb-connector-pe51698-p.aspx>

The information contained within this document is accurate to the best of our knowledge and representative of the part described herein. It may be necessary to make modifications to the part and/or the documentation of the part in order to impliment improvements. Pasternack Enterprises reserves the right to make such changes as required. Unless otherwise stated, all specifications are nominal. Pasternack Enterprises does not make any representation or warranty regarding the suitability of the part described herein for any particular purpose, and Pasternack Enterprises does not assume liability arising out of the use of any part or document.

# PE51698 CAD Drawing

MCX Jack Right Angle Commercial Grade Connector Solder Attachment Thru Hole PCB

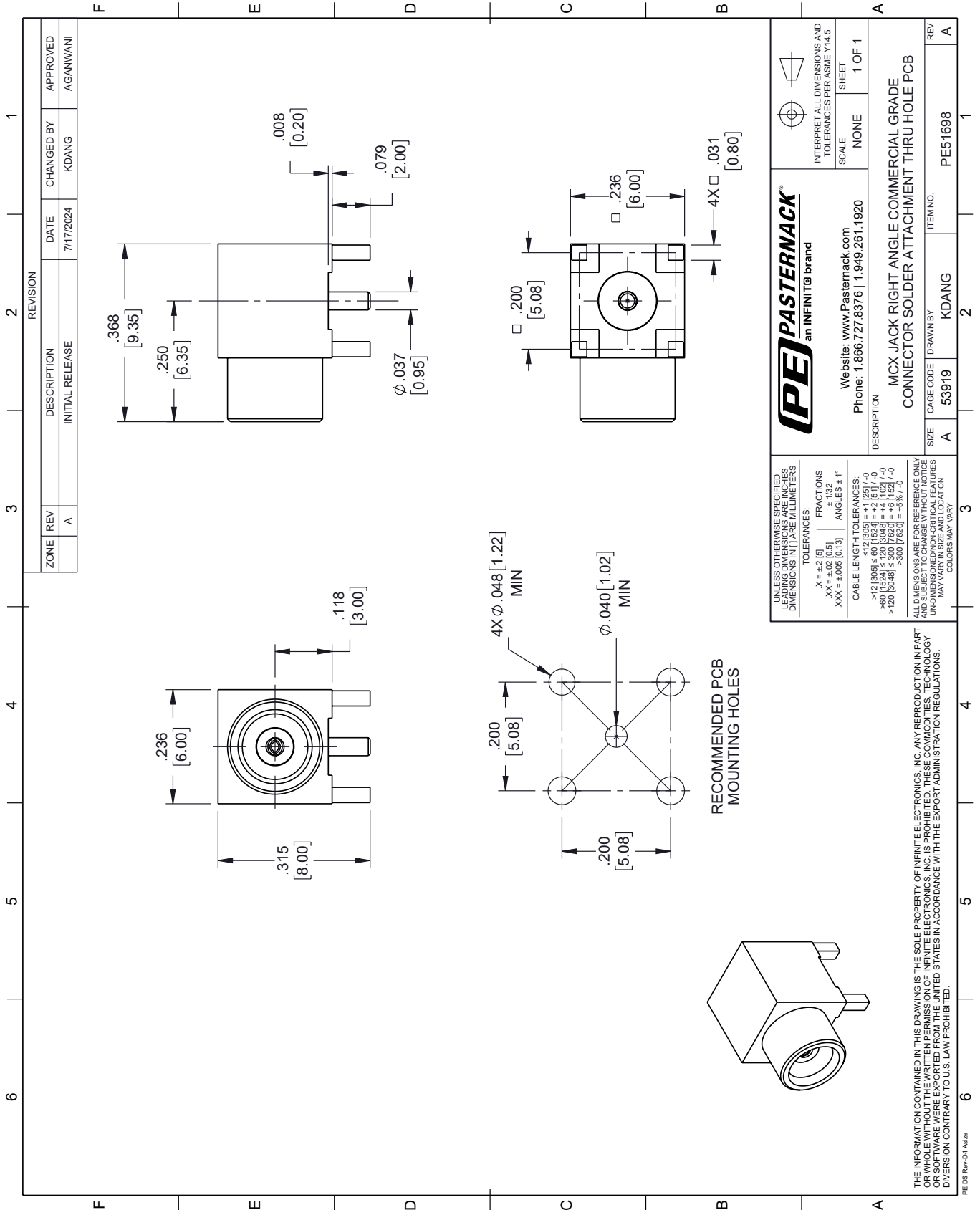

**(PE) PASTERNAK®**  
an INFINIT® brand

Website: [www.Pasternack.com](http://www.Pasternack.com)  
 Phone: 1.866.727.8376 | 1.949.261.1920

INTERPRET ALL DIMENSIONS AND TOLERANCES PER ASME Y14.5

SCALE: NONE      SHEET: 1 OF 1

DESCRIPTION: MCX JACK RIGHT ANGLE COMMERCIAL GRADE CONNECTOR SOLDER ATTACHMENT THRU HOLE PCB

SIZE: A      CAGE CODE: 53919      DRAWN BY: KDANG      ITEM NO.: PE51698

REV: A