

Ultra Low Power sub 1GHz Multichannels Radio Transceiver

The **RC-CC1314R** module is based on Texas Instruments CC1314R106T0RGZ component. This device combines a flexible, very low power RF transceiver with a powerful 48 MHz ARM Cortex M33 processor in a platform supporting multiple physical layers and RF standard. This device is pin to pin compatible with the module RC-CC1310-XXX and RC-CC1312R-XXX.

Operative Frequency Band : 868MHz / 915MHz



Sub-1GHz technology is becoming one of the chief driving forces behind the **Internet of Things (IoT)**, in particular this type of module is ideal for this applications basically for the following reasons :

Ultra low power consumption, the consumption of this device is 5.5mA when receiving and 23.5mA when transmitting at +14dBm (13.4mA at +10dBm) in sleep mode the consumption is 0.6µA (microamps).

Long range operations, the sensitivity parameter is -110dBm at data rates of 50 kbps and down to -124dBm when the data rate is 0.625kbps.

Interference from other wireless communications can be overcome with 90dB of blocking.

The RF output power levels can reach up to +14dBm.

All this ensure a robust signaling for long range communications.

SimpleLink-Easylink compatibility, ultra-low power platform designed (from TI) to easily implement the long-range connectivity with low power consumption on the Internet of Things projects (IoT).

TI-15.4 Stack, IEEE802.15.4e/g Standard Based Star Networking Software Designed for long range & robust star networks

6LoWPAN compatibility with mesh network stack for **Contiki**.

Applications :

- Low-Power Wireless Systems
- Smart Grid and Automatic Meter Reading
- Home and Building Automation
- Wireless Sensor Network
- 6LoWPAN systems

Feature :

- IEEE 802.15.4g mode switch support
- Ultra Low consumption technology
- Powerful ARM Cortex M4
- Supported by the open platform Contiki 6LoWPAN.
- Very Small size

Technical Characteristics

RC-CC1314R					
Parameter	Symbol	Min.	Typ.	Max.	Units
Operating Voltage	V_{CC}	1.8	3.00	3.8	VDC
Supply Current RX Mode	I_{CRX}		5.80		mA
Supply Current TX Mode +10dBm	I_{CTX1}		13.40		mA
Supply Current TX Mode +14dBm	I_{CTX2}		24.90		mA
Supply Current Standby Mode	I_{CSTB}		0,85		μ A
Supply Current Shut Down Mode	I_{CSHU}		150		nA
Operative Frequency	F_{of}		868/915		MHz
Frequency Error	F_{pp}		± 10		ppm
RF Power Output 50ohm (*)	P_{oo}	-10.0		+14.0	dBm
RF Sensibility 50kbps	S_d		-110.0		dBm
RF Sensibility Long Range Mode 625bps	S_{LR}		-121.0		dBm
Data Rate (*)	D_{CC}	0,01		4.0	Mbit/s
Operative Temperature	T_{LR}	-30		+75	$^{\circ}$ C

(*) Programmable parameter.

MICROCONTROLLER:

- Powerful 48MHz ARM Cortex - M33 Processor
- 1024KB of in-system Programmable Flash
- 256KB of ROM for protocol and library function
- 8KB of SRAM for Cache
- 256KB of Ultralow Leakege SRAM
- Support Over-the-Air Upgrade (OTA)

Development Tools and Software from TI

- LP-EM-CC1314R10
- SimpleLink™ CC13X2-CC26X2 Software Development Kit
- SmartRF™ Studio for simple radio configuration
- Sensor Controller Studio for building low-power sensing applications

For more information and details, please refer to the CC1314R Texas Instruments datasheet.

Block Diagram

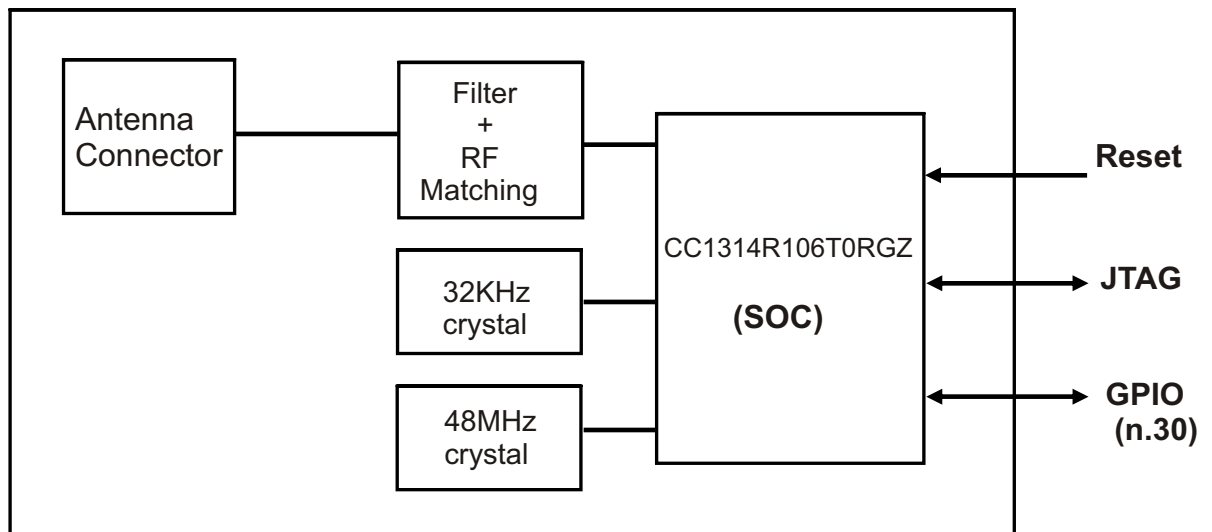

Reference Schematics

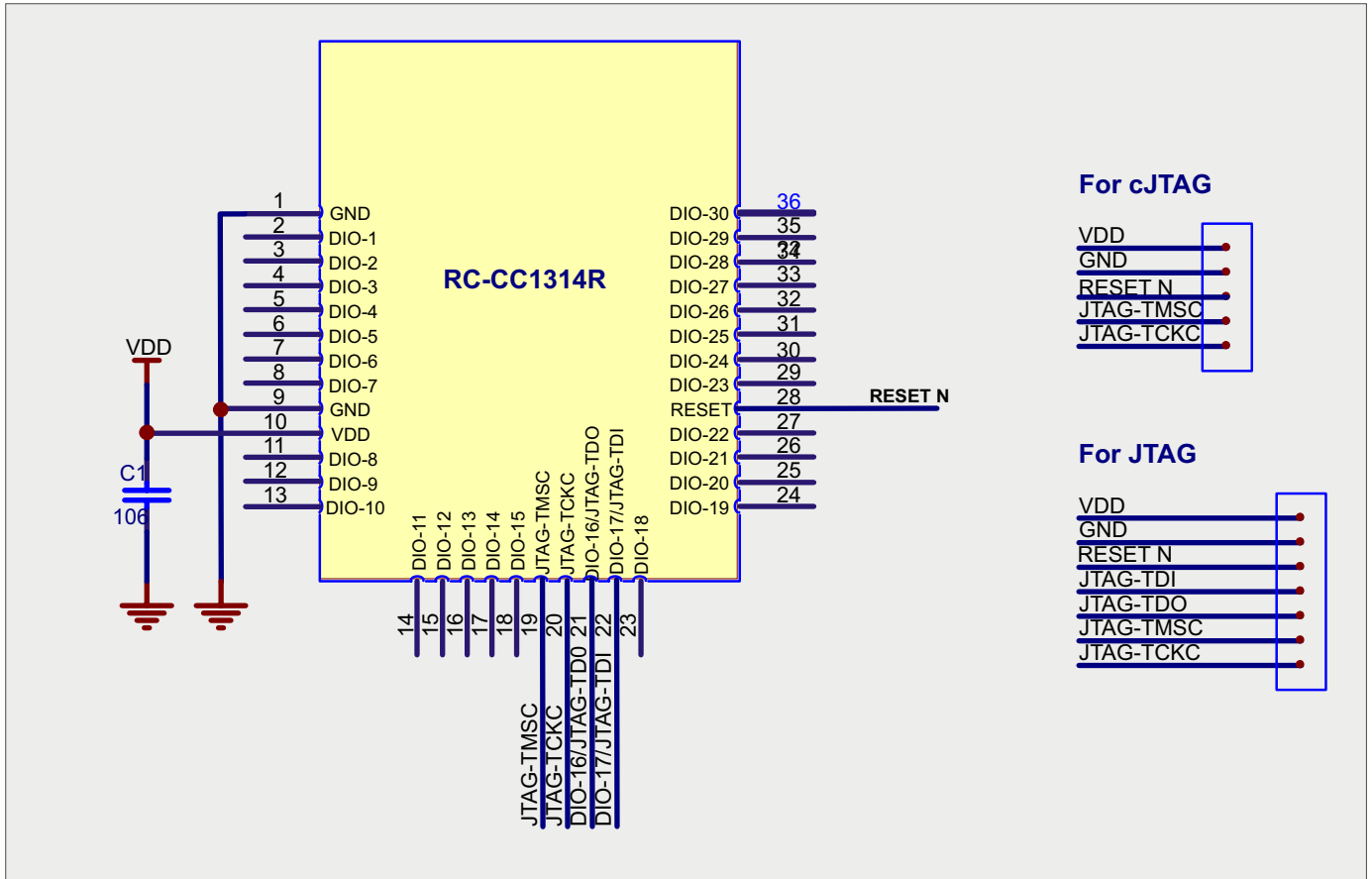

Mechanical Dimension

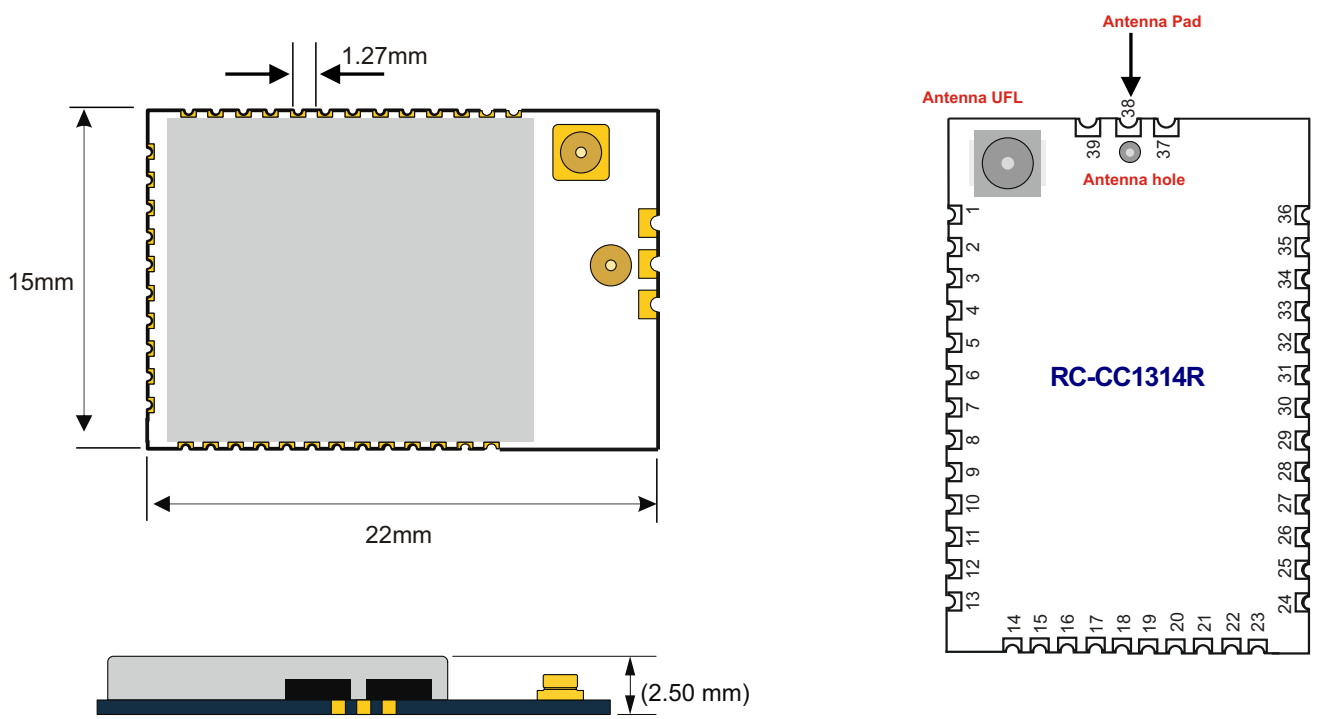

Terminal description RC-CC1314R

Pads	Name	Description
1	GND	Ground
2	DIO-1	GPIO
3	DIO-2	GPIO
4	DIO-3	GPIO
5	DIO-4	GPIO
6	DIO-5	GPIO, High drive capability
7	DIO-6	GPIO, High drive capability
8	DIO-7	GPIO, High drive capability
9	GND	Ground
10	VDD	Power
11	DIO-8	GPIO
12	DIO-9	GPIO
13	DIO-10	GPIO
14	DIO-11	GPIO
15	DIO-12	GPIO
16	DIO-13	GPIO
17	DIO-14	GPIO
18	DIO-15	GPIO
19	JTAG-TMSC	JTAG TMSC, High drive capability
20	JTAG-TCKC	JTAG TCKC
21	DIO-16	GPIO, JTAG -TDO, High drive capability
22	DIO-17	GPIO, JTAG-TDI, High drive capability
23	DIO-18	GPIO
24	DIO-19	GPIO
25	DIO-20	GPIO
26	DIO-21	GPIO
27	DIO-22	GPIO
28	RESET-N	RESET, (Active low - Internal pull up)
29	DIO-23	GPIO, Analog capability
30	DIO-24	GPIO, Analog capability
31	DIO-25	GPIO, Analog capability
32	DIO-26	GPIO, Analog capability
33	DIO-27	GPIO, Analog capability
34	DIO-28	GPIO, Analog capability
35	DIO-29	GPIO, Analog capability
36	DIO-30	GPIO, Analog capability
37	GND	Ground
38	Antenna	Antenna PAD
39	GND	Ground

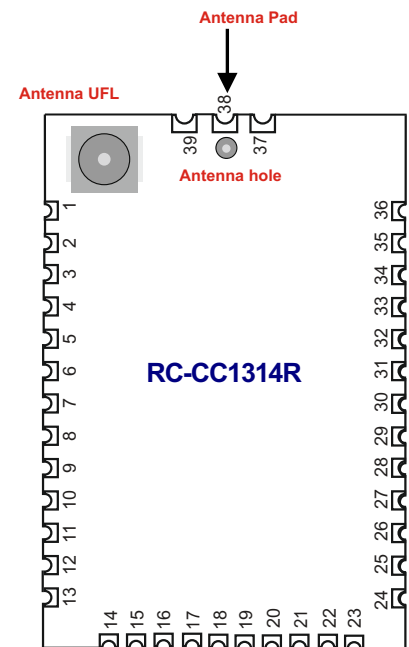

Pin out device

Type of Antenna connection

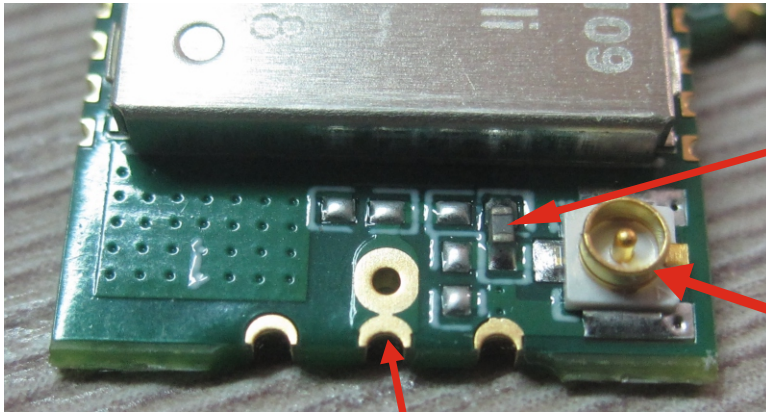

Antenna pad connector

Chip selector

UFL connector

Difference between standard version and «H» version

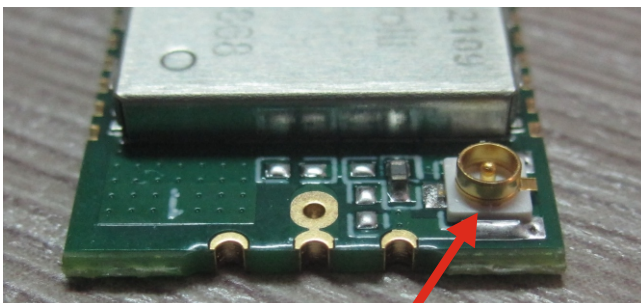

RC-CC1314R

- With UFL Connector
- Antenna connection to the UFL connector

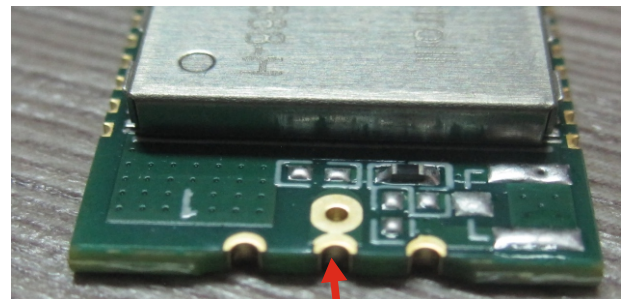

RC-CC1314R-H

- Without UFL Connector
- Antenna connection to hole and pad



RC-CC1314R



RC-CC1314R-H

RC-CC1314R Adapter board

To make immediate usable the RC-CC1314R module with TI development systems has been realized the following board adapter.



Adapter board front

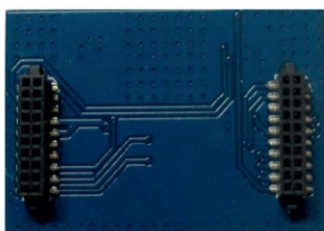

Adapter board rear



SMART RF06 Evaluation board (TI)

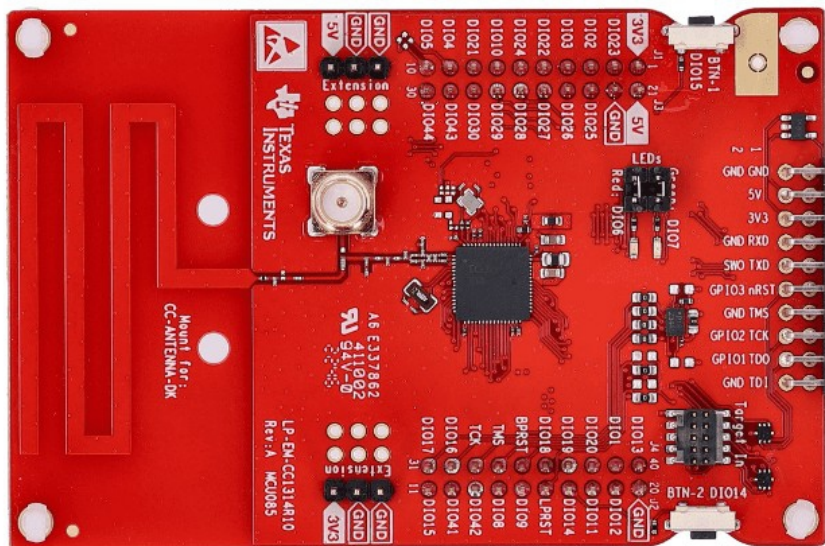

- GND to pin 9
- 3V3 to pin 10
- RST to pin 28
- TMS to pin 19
- TCK to pin 20
- TDO to pin 21
- TDI to pin 22

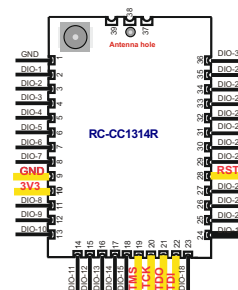

Texas Instruments Launchpad Connection

Recommended Hardware design

1) Hardware

All unused pins should be left floating; do not ground.
All GND pins must be well grounded.
Traces should not be routed underneath the module.

2) Power Supply

The transceiver module must be powered from a regulated voltage.
It is recommended to keep the power supply line for VCC as short and low impedance as possible. Near the power pins it is recommended to insert a ceramic the decoupling capacitor (100nF).

3) Ground Plane

It is recommended to have a copper ground plane under the shielded zone of the module. The ground plane should be unbroken.

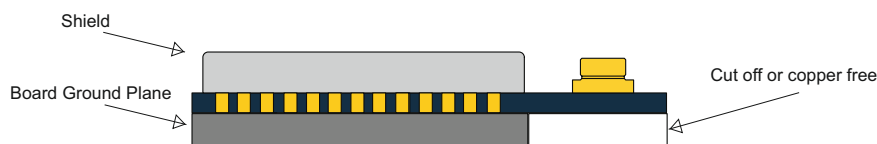

4) Module Placement

The antenna on the PCB has an omnidirectional radiation pattern. To maximize antenna efficiency, an adequate grounding plane must be provided under the module. Instead the areas underneath and surrounding the antenna area must be free of copper.

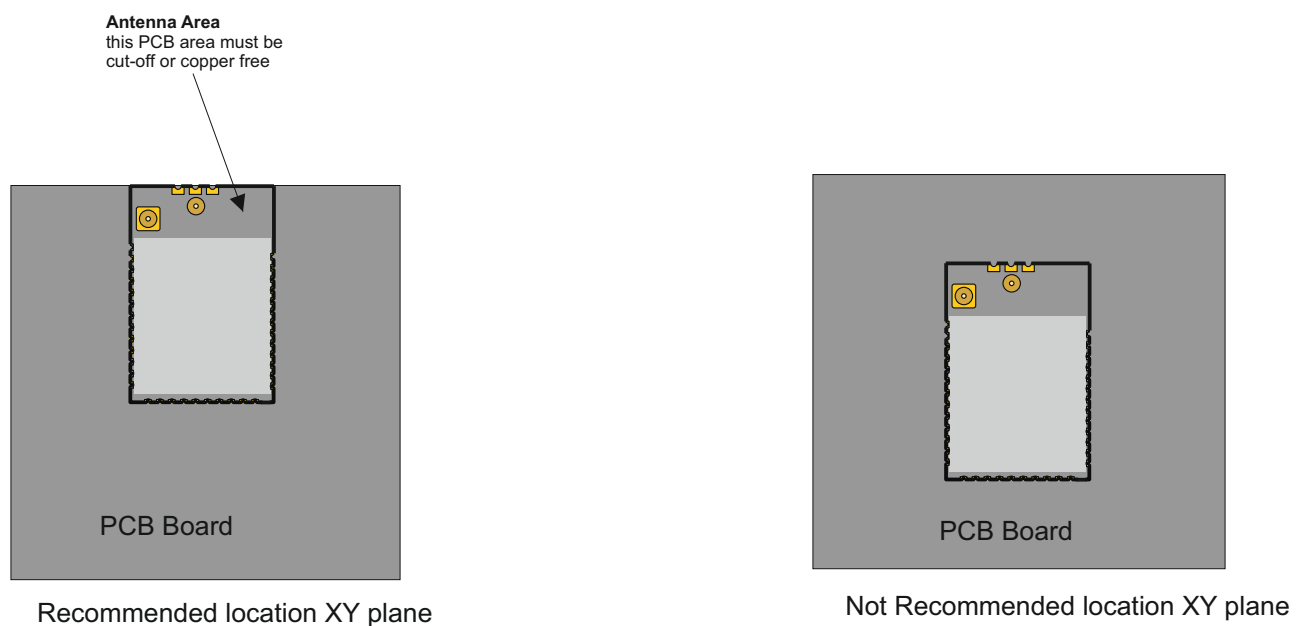

REEL DIMENSIONS

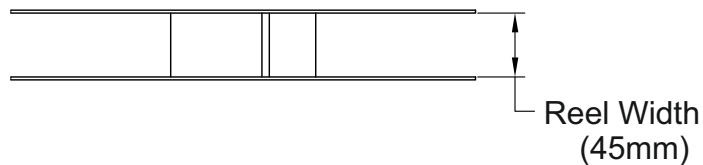
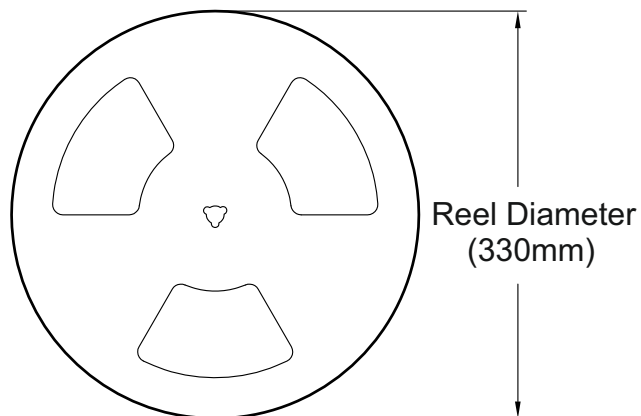

TAPE DIMENSIONS

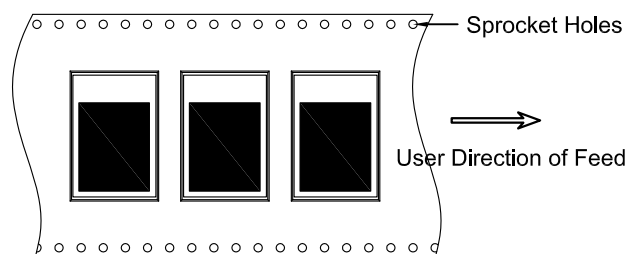
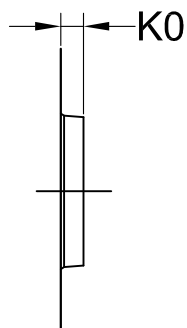
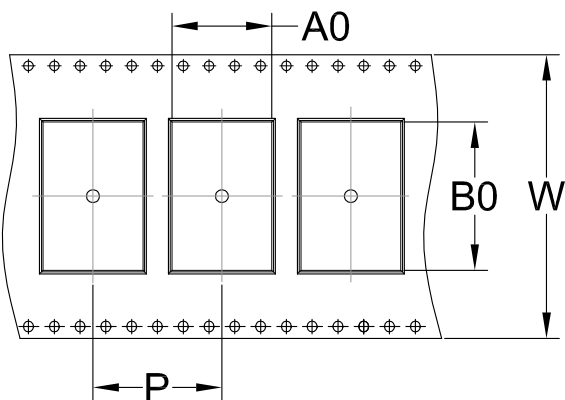

A0	Dimension designed to accommodate the component width	15.5mm ± 0.10mm
B0	Dimension designed to accommodate the component length	23.0mm ± 0.10mm
K0	Dimension designed to accommodate the component thickness	3.5mm ± 0.10mm
W	Overall width of the carrier tape	44.0mm ± 0.30mm
P	Pitch between successive cavity centers	20.0mm ± 0.10mm