

## ZBF-603Xcc3B

### 5G Cellular Adhesive Blade antenna

The Joymax ZBF-603Xcc3B series antennas are adhesive-mount, dipole antennas designed for use in 5G New Radio FR1, LTE, and Cellular IoT (LTE-M, NB-IoT) applications with broad band coverage from 617 MHz to 7125 MHz, the antenna also supports CBRS (3550 MHz to 3700MHz), Public Safety (4940 MHz to 4990 MHz), and a growing number of C-Band solutions.

The antennas feature a low-profile, durable housing that mounts permanently with integral adhesive to flat, non-conductive surfaces such as windows, drywall, ceiling tiles, plastic, etc. Connection is made to the radio via a coaxial cable terminated in an SMA plug (male pin).



#### Features

- Bandwidth 617 MHz to 7125 MHz
- Performance at 617 MHz to 960 MHz  
VSWR:  $\leq 1.9$   
Peak Gain: 3.2dBi  
Efficiency: 46%
- Ground plane independence dipole design
- Compact size, low profile
- Adhesive backing permanently adheres to non-metallic enclosure/chassis using 3M 1600TG
- Custom length cable for OEM customers

#### Applications

- 5G NR FR1, 4G, 3G, 2G, CBRS
- Cellular IoT: LTE-M (Cat-M1), NB-IoT
- CBRS Private Network (3550 to 3700MHz)
- C-Band applications (3700 to 4200MHz)
- Public Safety networks (4940 to 4990MHz)
- Internet of Things (IoT) devices

#### Ordering Information

Part Number	Description
<b>ZBF-603XSA3B-P100</b>	5G Cellular Adhesive Mount Blade antenna with SMA plug (male pin), L=1000mm
<b>ZBF-603XSA3B-P200</b>	5G Cellular Adhesive Mount Blade antenna with SMA plug (male pin), L=2000mm
<b>ZBF-603XFK3B-P100</b>	5G Cellular Adhesive Mount Blade antenna with Fakra Plug connector, L=1000mm
<b>ZBF-603XFK3B-P200</b>	5G Cellular Adhesive Mount Blade antenna with Fakra Plug connector, L=2000mm

Available from Joymax Electronics and select distributors and representatives.

**Table 1: Electrical Specifications**

ZBF-603Xcc3B	5G NR / LTE Bands (MHz)					
Frequency Range	617~960	1710~2690	3300~4200	4400~5000	5150~5850	5925-7125
VSWR (Max)	1.9	1.6	1.6	1.6	1.6	1.8
Peak Gain (dBi)	3.2	2.5	0.3	-1.5	0.5	0.2
Average Gain (dBi)	-3.5	-4.2	-5.7	-7.8	-7.3	-9.0
Efficiency (%)	46	39	28	17	19	13
Polarization	Linear					
Radiation	Omni directional					
Max Power	1 W					
Wavelength	$\frac{1}{2}\lambda$					
Electrical Type	Dipole					
Impedance	50 $\Omega$					

Electrical specifications and plots measured with the antenna adheres to a non-conductive plate (150x150mm) with 2 meter long coax cable.

**Table 2: Mechanical Specifications**

Parameter	Value
Connection	SMA Plug (male pin) or Fakra Plug Connector
Operating Temp.	-30°C to +70°C
Weight	37 g
Dimension	110 mm x 20 mm x 5.4 mm
Antenna Color	Black
Ingress Protection	N/A

## Packaging Information

The ZBF-603Xcc3B antennas are individually sealed in a clear plastic bag. **Figure 1.** 200 pcs per carton, 420 mm x 310 mm x 260 mm (16.5 in x 12.2 in x 10.2 in), total weight 8.4 kgs (18.5 lb) Distribution channels may offer alternative packaging options.



1 pce antenna/ 1 PE bag

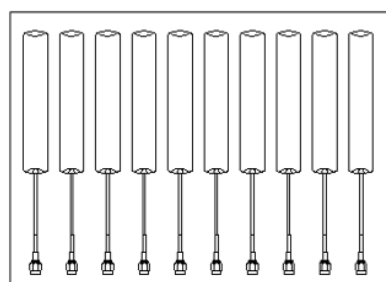

20 pcs antenna/ 1 Bigger PE bag

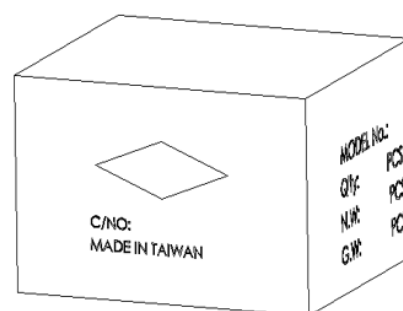

200 pcs antenna/1 Carton

**Figure 1. Antenna Packaging**

### Product Dimensions

Figure 2 provides dimensions of the ZBF-603Xcc3B in mm measurement unit. The antenna mounts permanently with integral 3M 1600TG adhesive to flat, non-conductive surfaces such as windows, drywall, ceiling tiles, plastic, etc. Connection is made to the radio via a coaxial cable terminated in an SMA plug (male pin).

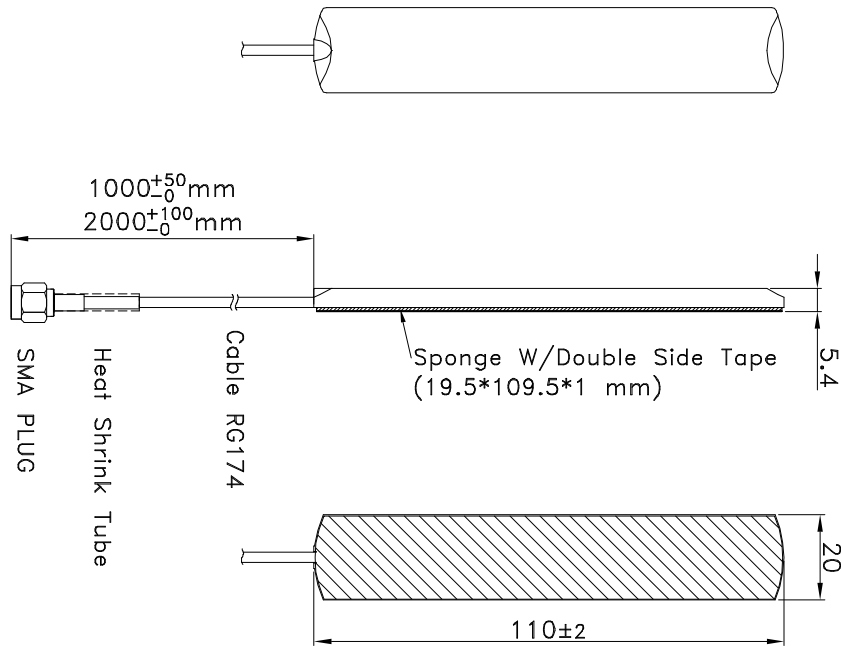

Figure 2. Antenna Dimensions

### Antenna Test Setup

The ZBF-603Xcc3B antenna is tested with adhere to a 150mm x 150mm non-conductive plate with 2 meter long coax cable as shown in Figure 3. That provides insights into antenna performance for real case adhesive mount installation. The charts on the following pages represent data taken with the antenna mount on the center of the non-conductive plate.

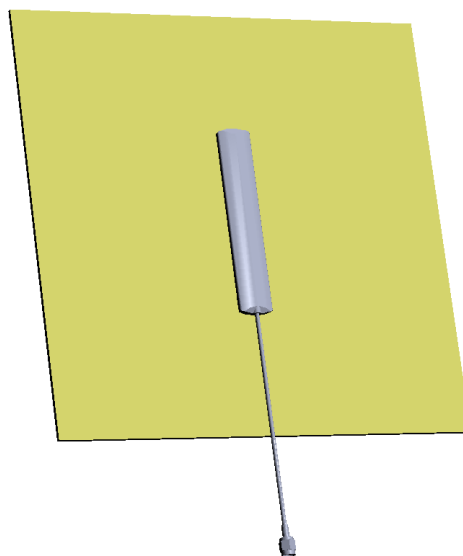

Figure 3. Antenna Test Setup

### VSWR

Figure 4 provides the voltage standing wave ratio (VSWR) across the antenna bandwidth. VSWR is a function of the reflection coefficient, which describes the power reflected from the antenna back to the radio. A lower VSWR value indicates better antenna performance at a given frequency. Reflected power is also shown on the right-side vertical axis as a gauge of the percentage of transmitter power reflected back from the antenna.

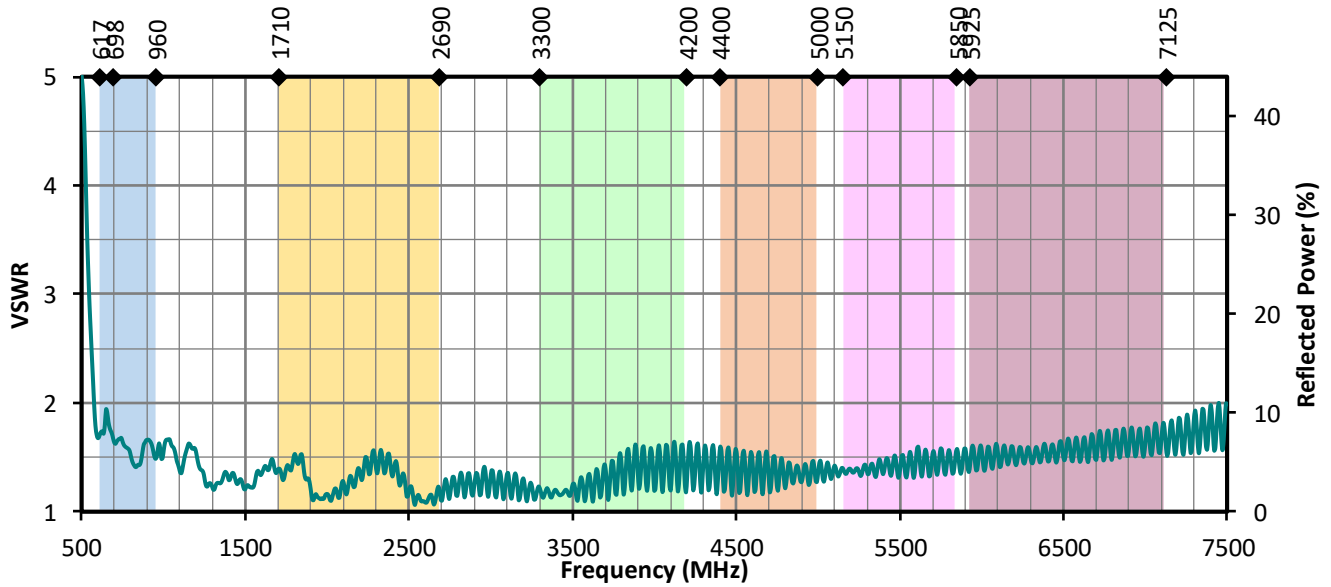

Figure 4. Antenna VSWR, No ground plane

### Return Loss

Return loss (Figure 5), represents the loss in power at the antenna due to reflected signals. Like VSWR, a lower return loss value indicates better antenna performance at a given frequency.

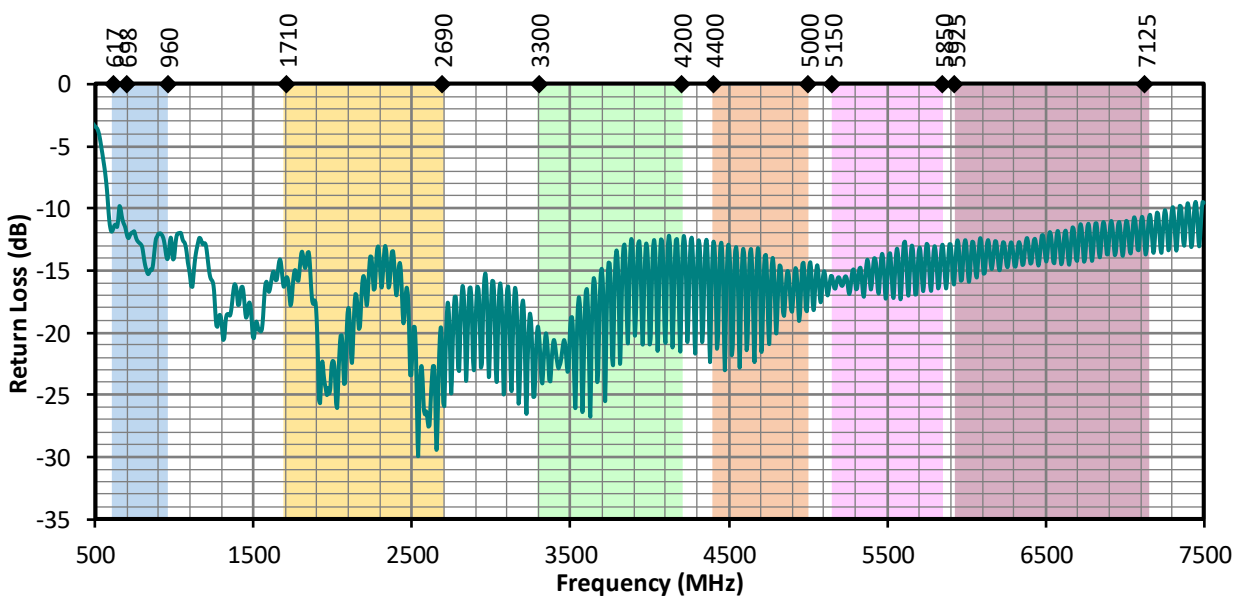

Figure 5. Antenna Return Loss, No ground plane

### Peak Gain

The peak gain across the antenna bandwidth is shown in **Figure 6**. Peak gain represents the maximum antenna input power concentration across 3-dimensional space, and therefore peak performance at a given frequency, but does not consider any directionality in the gain pattern.

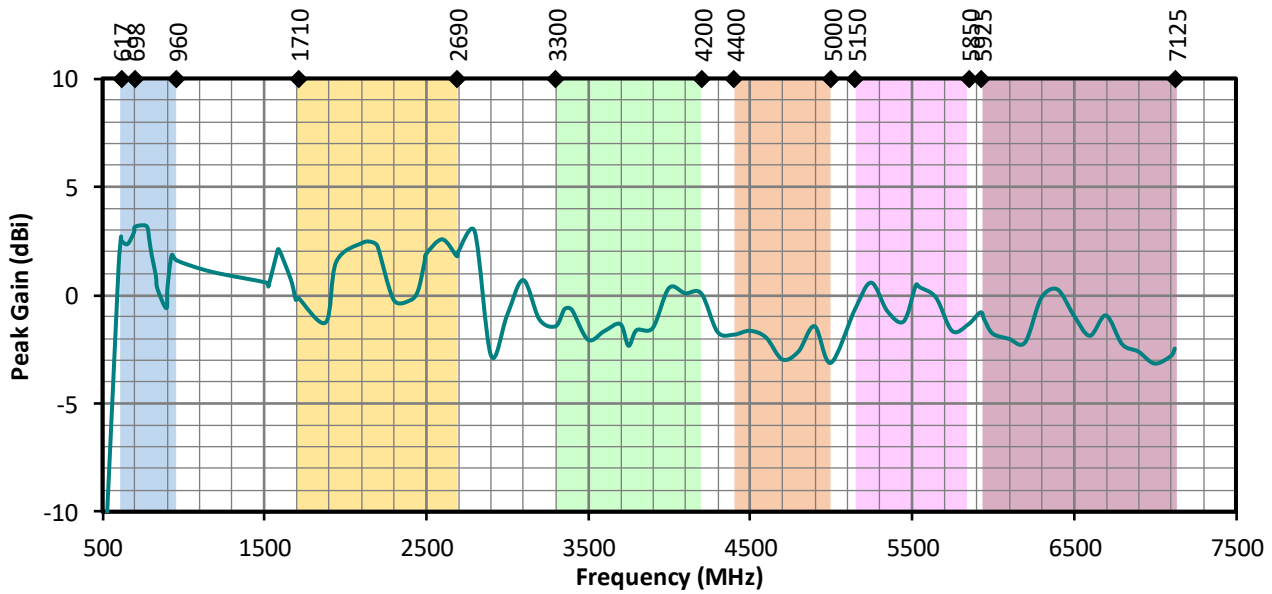

Figure 6. Antenna Peak Gain, No ground plane

### Average Gain

Average gain (**Figure 7**), is the average of all antenna gain in 3-dimensional space at each frequency, providing an indication of overall performance without expressing antenna directionality.

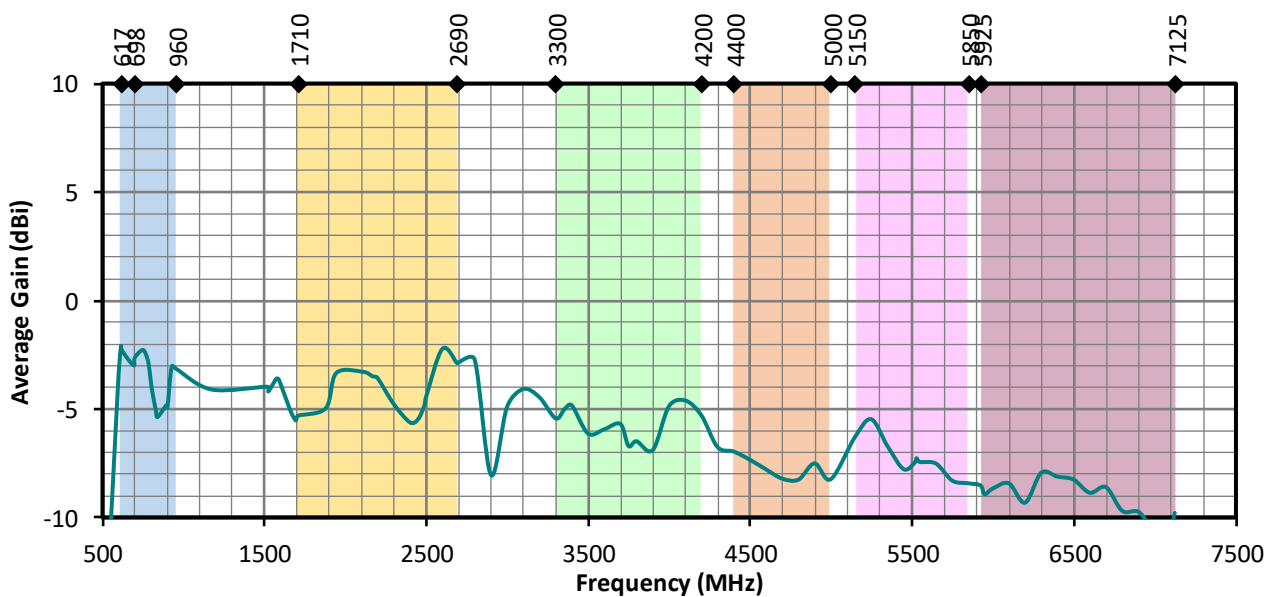

Figure 7. Antenna Average Gain, No ground plane

### Radiation Efficiency

Radiation efficiency (**Figure 8**), shows the ratio of power radiated by the antenna relative to the power supplied to the antenna, expressed as a percentage, where a higher percentage indicates better performance at a given frequency. An ideal antenna has 100% efficiency. But in really world, usually an external antenna radiates only 50~60% of power supplied to it.

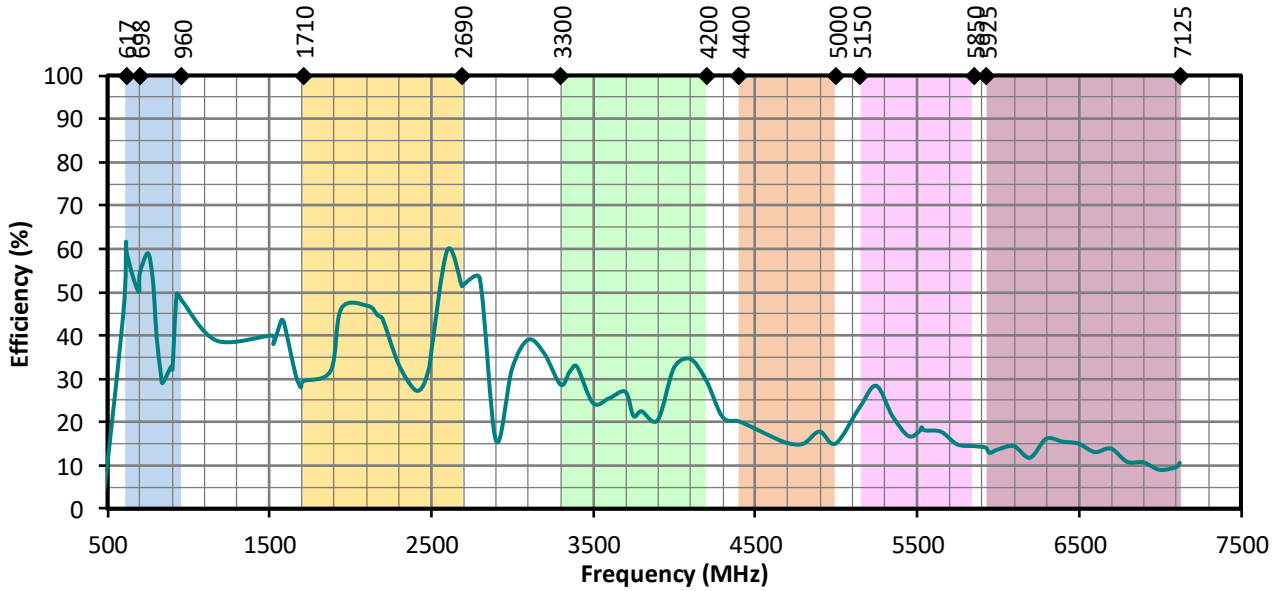
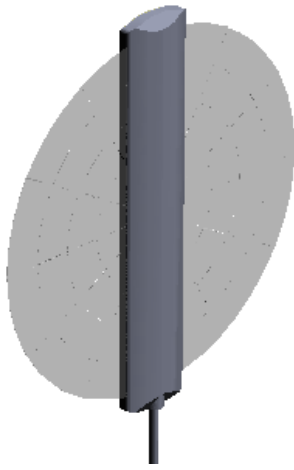

Figure 8. Antenna Efficiency, No ground plane

### Radiation Patterns

Radiation patterns provide information about the directionality and 3-dimensional gain performance of the antenna by plotting gain at specific frequencies in three orthogonal planes. Antenna radiation patterns for a straight orientation are shown in **Figure 9** using polar plots covering 360 degrees. The antenna graphic at the top of the page provides reference to the plane of the column of plots below it.



XZ-Plane Gain

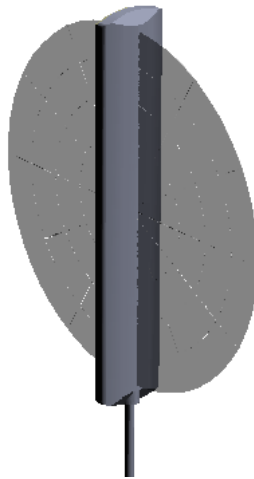

YZ-Plane Gain

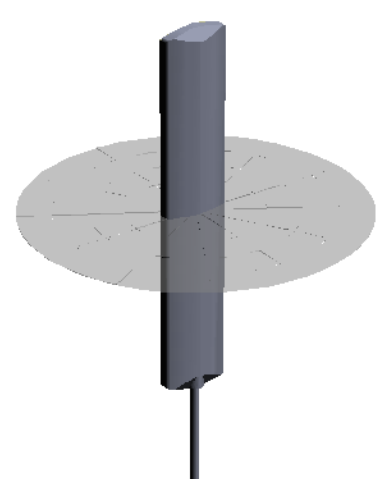

XY-Plane Gain

### 617 MHz to 960 MHz (778 MHz)

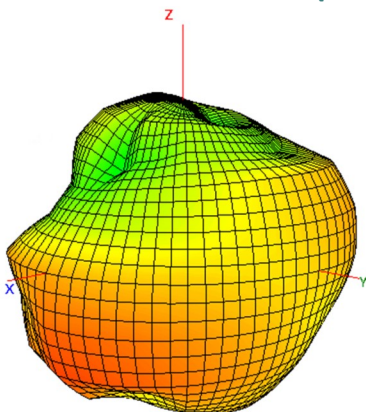

617 MHz

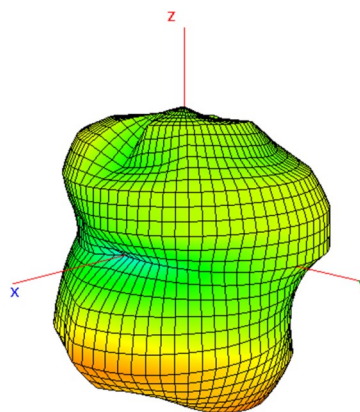

778 MHz

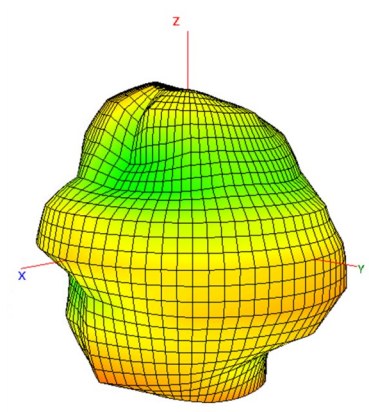

960 MHz

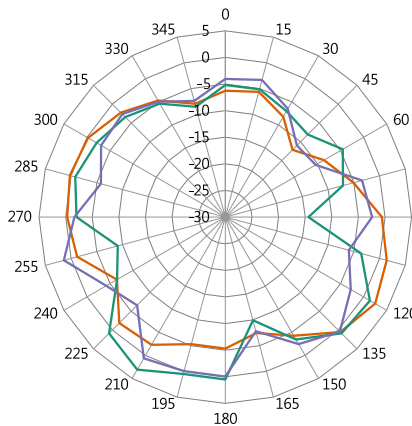

XZ-Plane Gain

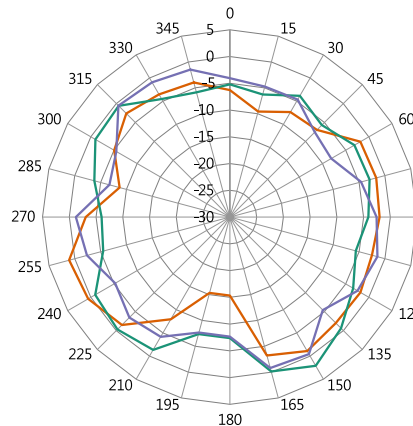

YZ-Plane Gain

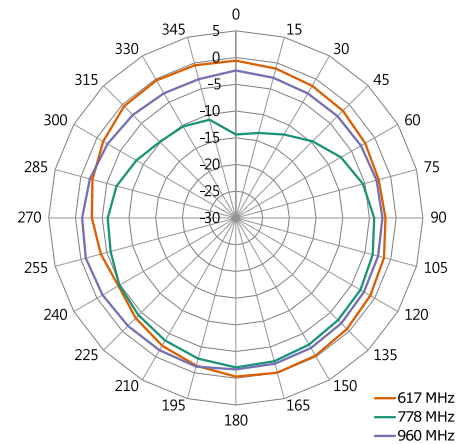

XY-Plane Gain

Figure 9. Antenna Radiation Patterns

1710 MHz to 5000 MHz (3355 MHz)

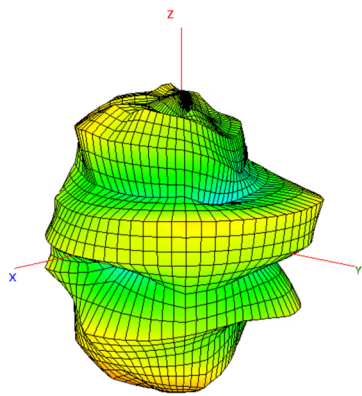

1710 MHz

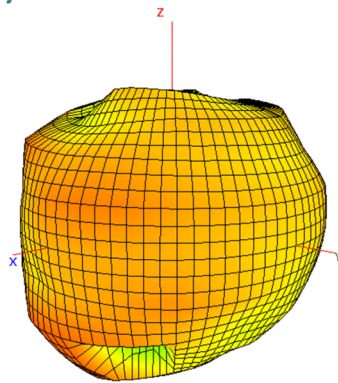

3355 MHz

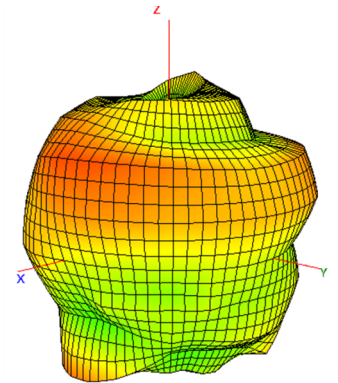

5000 MHz

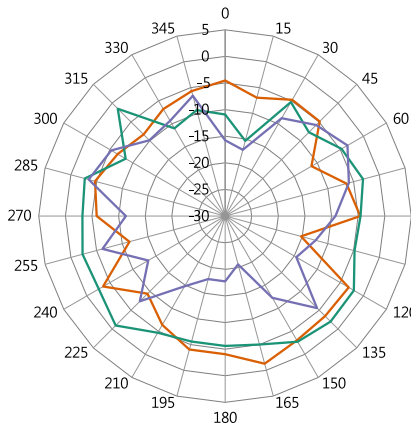

XZ-Plane Gain

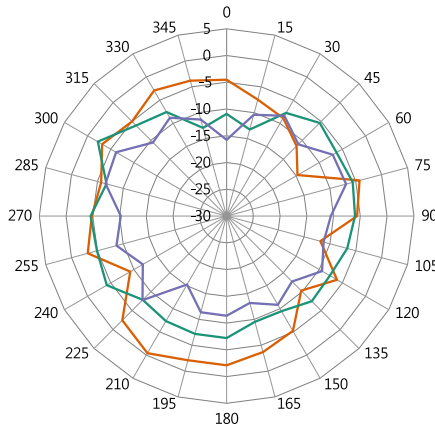

YZ-Plane Gain

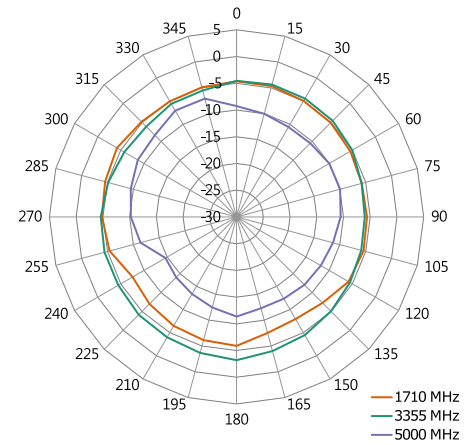

XY-Plane Gain

5150 MHz to 5850 MHz (5550 MHz)

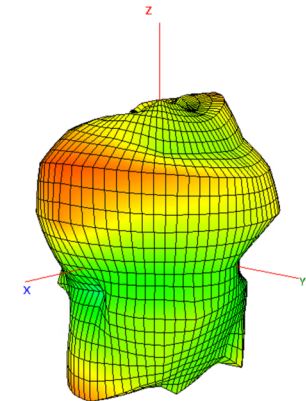

5150 MHz

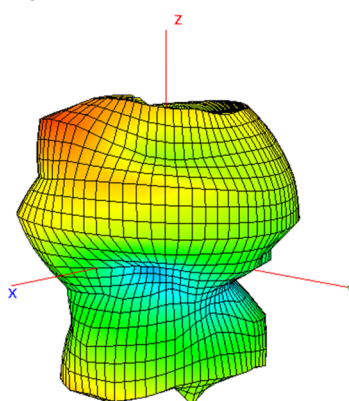

5500 MHz

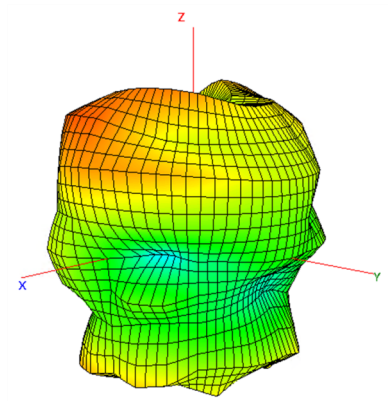

5850 MHz

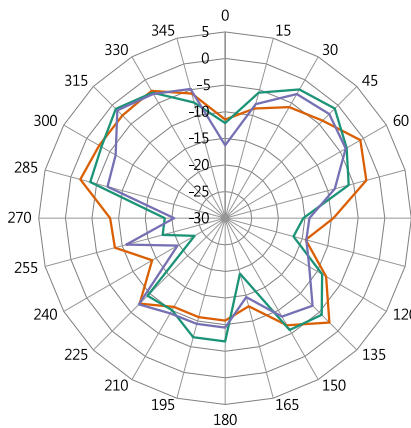

XZ-Plane Gain

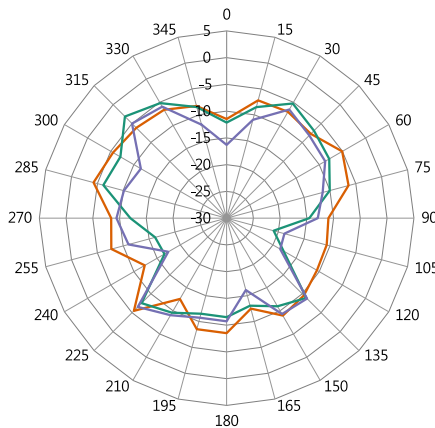

YZ-Plane Gain

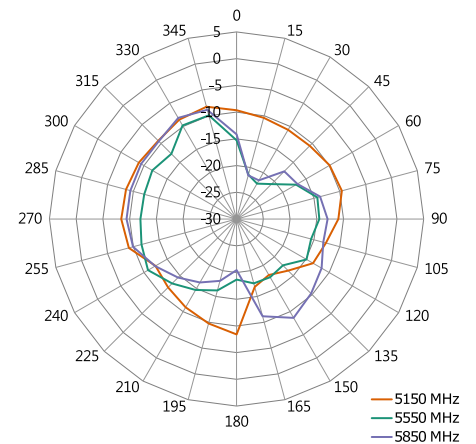

XY-Plane Gain

5925MHz to 7125MHz (6525MHz)

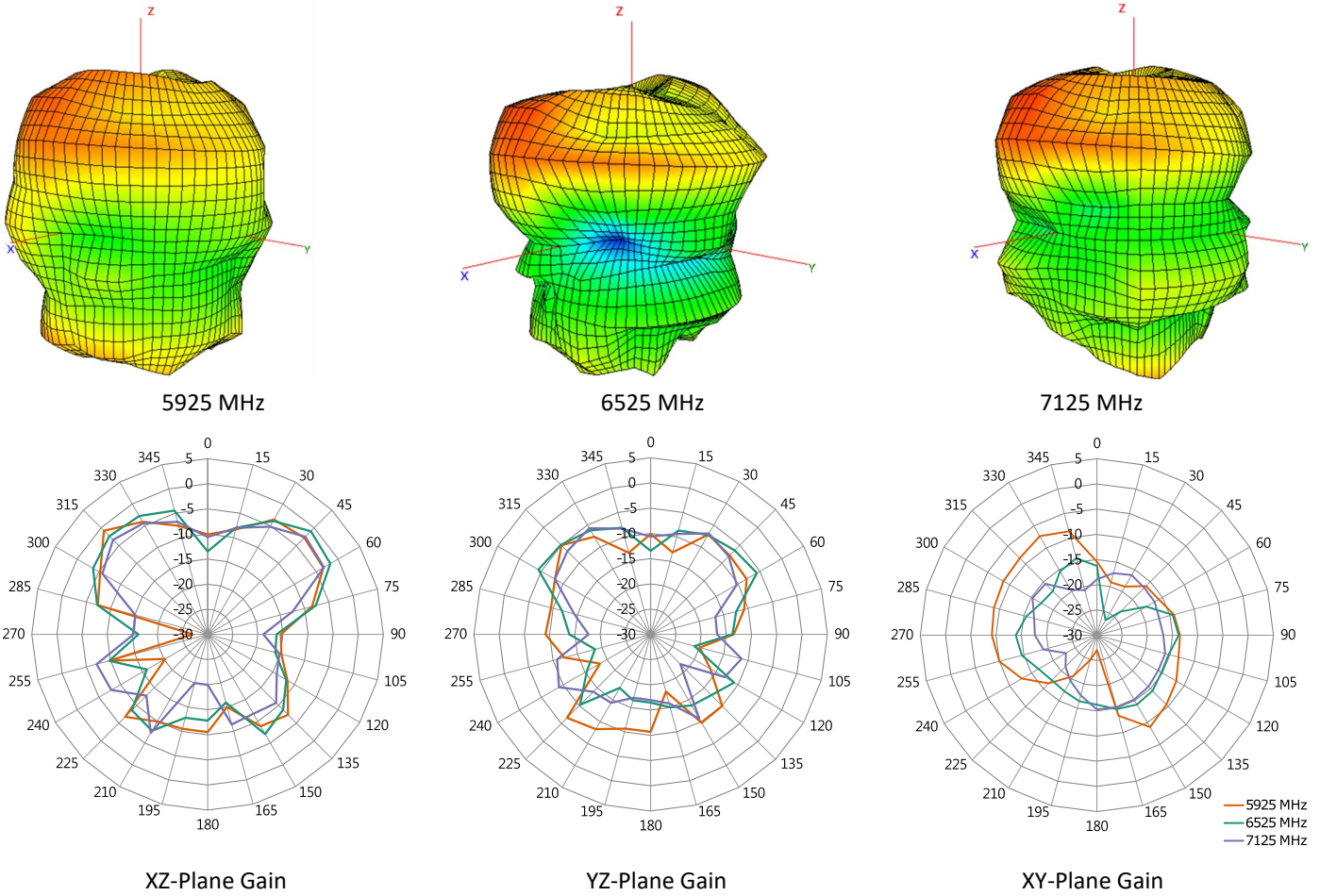

Figure 9-1. Antenna Radiation Patterns

## Antenna FAQs

### Q: What is an antenna?

An antenna is used for transmission or reception of radio signals in wireless communication.

### Q: How do antennas work?

Electricity flowing into the transmitter antenna makes electrons vibrate up and down it, producing radio waves. The radio waves travel through the air at the speed of light. When the waves arrive at the receiver antenna, they make electrons vibrate inside it.

### Q: Does antenna size matter?

A bigger antenna, properly designed, will always have more **gain** than a smaller one. And it will be the best kind of **gain**, much better than using a small antenna and simply over-amplifying it, because a small antenna just won't pull in truly weak signals like this gigantic one will.

### Q: What is the advantage of external antennas?

External antennas usually offer **better bandwidth** and **high performance** due to the nature of their larger size. This often results in a higher rated **gain** (dBi) than their internal counterparts. Due to its smaller size, an internal antenna would not function well to support lower frequencies.

Ease of integration – an external antenna requires fewer design resources and shorter time to integrate to allow for a more rapid time-to-market. An internal antenna's performance is influenced by device environment – PCB ground plane, nearby metal part, and enclosure. That would require much more effort such as impedance matching network to complete antenna design.





### Q: Why is most antenna impedance 50 Ohm?

50 Ohm is an industry standard of coax cables and power amplifiers. It was chosen as a tradeoff between maximum power handling for the transmit coax and the copper losses. The optimum would have been anyway in the range of **30 to 100 ohm** with average at 50 Ohm.

### Q: Why does GNSS require RHCP (Right-hand-circularly-polarized) antennas?

Satellite's signal has a low power density, especially after propagating through the **atmosphere** (**ionosphere** affect radio wave). Polarized waves oscillate in more than one direction, which deliver satellite's signal to receiver on Earth surface more effectively.

## MATING COMPONENTS: RF COAXIAL CONNECTOR AND CABLE ASSEMBLY

Part Number	Image	Connector 1 (Receptacle)	Connector 2 (Plug)	Cable Length		Cable Diameter (mm)
				mm	Inch	
<a href="#">CX-SAS0MMPA1W0007</a>		SMA Jack Female Socket Straight	MHF1	70	2.76	1.13
<a href="#">CT-SAB11X-006M</a>		SMA Jack Female Socket Right Angle	N/A	N/A	N/A	N/A
<a href="#">CT-SAD12X-006M</a>		RP-SMA Jack Male Pin Straight	N/A	N/A	N/A	N/A
<a href="#">CT-SAD11X-006M</a>		RP-SMA Jack Male Pin Right Angle	N/A	N/A	N/A	N/A
<a href="#">CX-SAT0MFA1W0030</a>		RP-SMA Jack Female Socket Straight	MHF4L	300	11.8	1.13

Website: <https://www.joymax.com.tw>

Offices: 5, Dong-Yuan 2<sup>nd</sup> Road, Zhong-Li Dist., Tao-Yuan City 32063 Taiwan (R.O.C.)

Phone: +886 3 433 5698

E-MAIL: [info@joymax.com.tw](mailto:info@joymax.com.tw)

Joymax Electronics reserves the right to make changes to the product(s) or information contained herein without notice. No liability is assumed as a result of their use or application. No rights under any patent accompany the sale of any such product(s) or information.

EnJOY MAX Wireless is a registered trademark of Joymax Electronics Co., Ltd. Other product and brand names may be trademarks or registered trademarks of their respective owners.

Copyright © 2024 Joymax Electronics  
All Rights Reserved.

01/24 RevA