

RC-SM1278-433

based on Semtech SX1278

It's a SX1278 LoRa module with SPI interface.



The RC-SM1278-433 module is designed based on Sx1278. The SX1278 incorporates the LoRa™ spread spectrum modem which is capable of achieving significantly longer range than existing systems based on FSK or OOK modulation. At maximum data rates of LoRa™ the sensitivity is 8dB better than FSK, but using a low cost bill of materials with a 20ppm XTAL LoRa™ can improve receiver sensitivity by more than 20dB compared to FSK. LoRa™ also provides significant advances in selectivity and blocking performance, further improving communication reliability. For maximum flexibility the user may decide on the spread spectrum modulation bandwidth (BW), spreading factor (SF) and error correction rate (CR). Another benefit of the spread modulation is that each spreading factor is orthogonal - thus multiple transmitted signals can occupy the same channel without interfering. This also permits simple coexistence with existing FSK based systems. Standard GFSK, FSK, OOK, and GMSK modulation is also provided to allow compatibility with existing systems or standards such as wireless MBUS and IEEE 802.15.4g.

Features

- LoRa™ Modem
- 168 dB maximum link budget
- +20 dBm - 100 mW constant RF output vs. V supply
- +14 dBm high efficiency PA
- Programmable bit rate up to 300 kbps
- High sensitivity: down to -148 dBm
- Bullet-proof front end: IIP3 = -11 dBm
- Excellent blocking immunity
- Low RX current of 12 mA, 200 nA register retention
- Fully integrated synthesizer with a resolution of 61 Hz
- FSK, GFSK, MSK, GMSK, LoRa™ and OOK modulation
- Built-in bit synchronizer for clock recovery

- Preamble detection
- 127 dB Dynamic Range RSSI
- Automatic RF Sense and CAD with ultra-fast AFC
- Packet engine up to 256 bytes with CRC
- Built-in temperature sensor and low battery indicator

Applications

- Automatic Measure Reading.
- Home and Building Automation.
- Wireless Security Systems.
- Home and Building Automation

1.0 Block Diagram

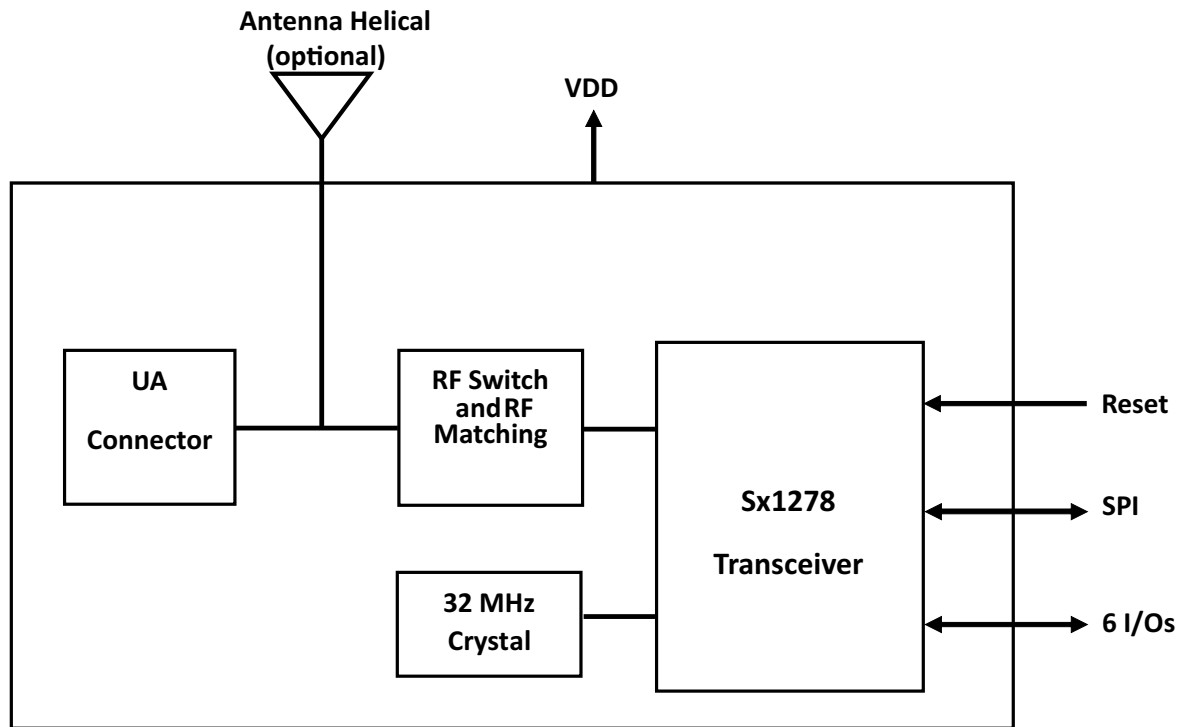

2.0 Technical Specifications

Characteristics	MIN	TYP	MAX	UNIT
Supply Voltage	1.8		3.6	VDC
Supply Current RX mode Bands 2&3		12.0	13.0	mA
Supply Current Sleep Mode		0.2	1	µA
Supply Current Transmit Mode RFOP=+20dBm		120	130	mA
RF Power Output(for LORA Modulation)		+18	+20	dBm
Frequency Band		433		Mhz
RF Sensitivity (for LORA Modulation)		- 139		dBm
Operative Temperature	-20		+70	°C

3.0 Pin Out and Mechanical Dimension

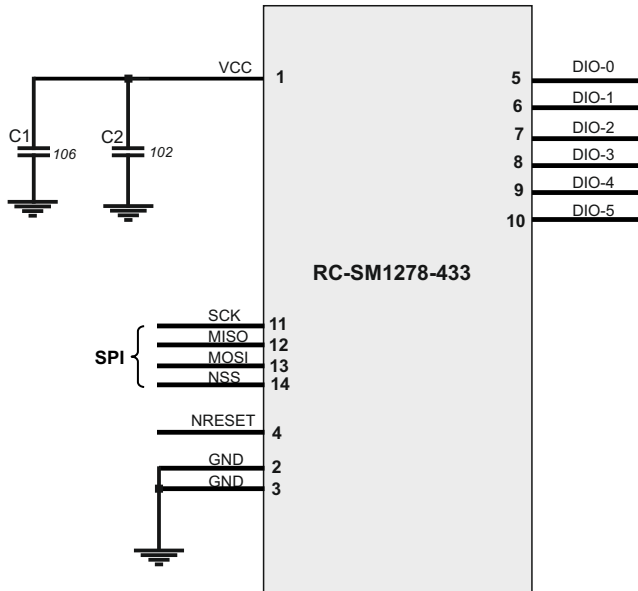

Mechanical Dimension

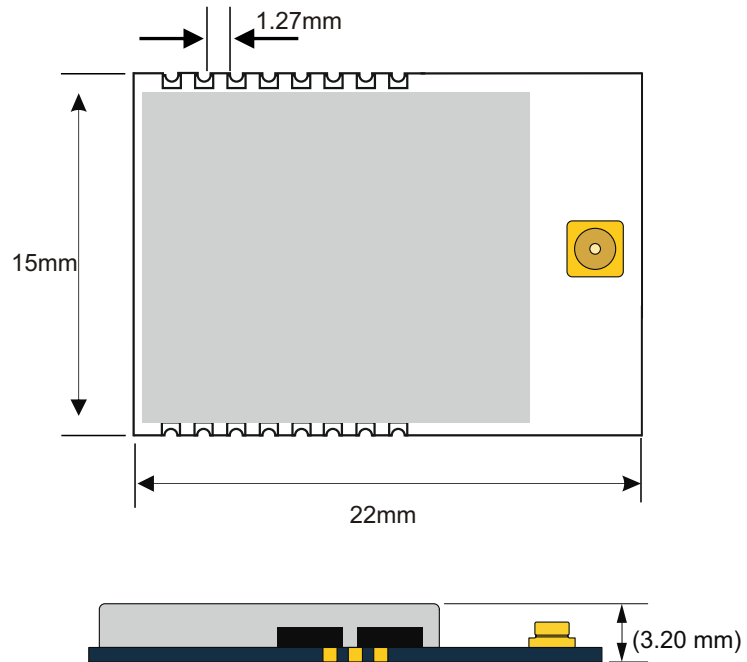

Pin out device

Pads	Name	Description
1	VDD	Power 1.8 to 3.6 Volt
2	GND	Ground
3	GND	Ground
4	NRESET	Reset Trigger Input
5	DIO-0	Digital I/O
6	DIO-1/DCLK	Digital I/O
7	DIO-2/DATA	Digital I/O
8	DIO-3	Digital I/O
9	DIO-4	Digital I/O
10	DIO- 5	Digital I/O
11	SCK	SPI Clock Input
12	MISO	SPI Data Output
13	MOSI	SPI Data Input
14	NSS	SPI Chip Select Input
15	NC	Not connected
16	NC	Not connected

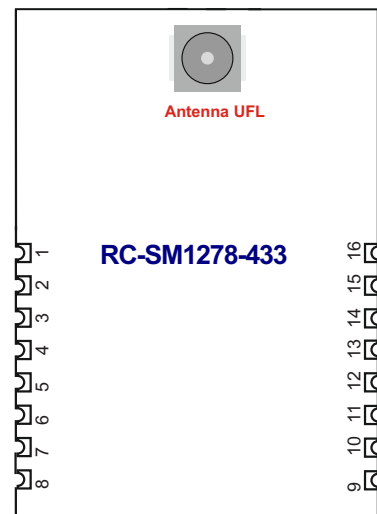

4.0 Recommended PCB Layout

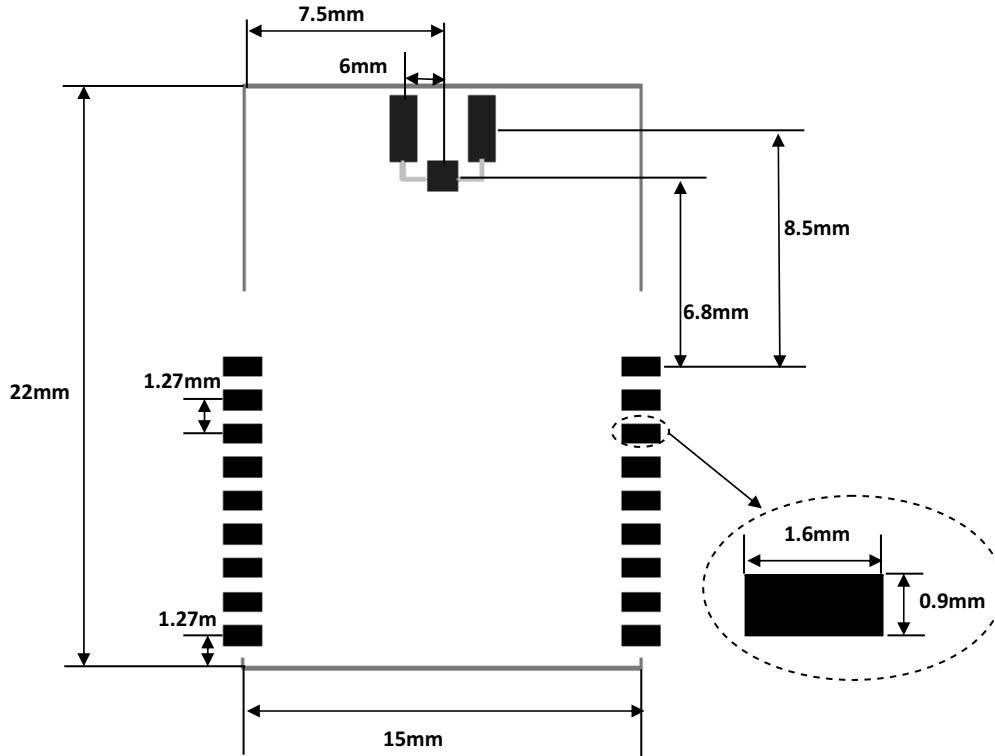

5.0 Recommended Reflow Profile for Lead Free Solder

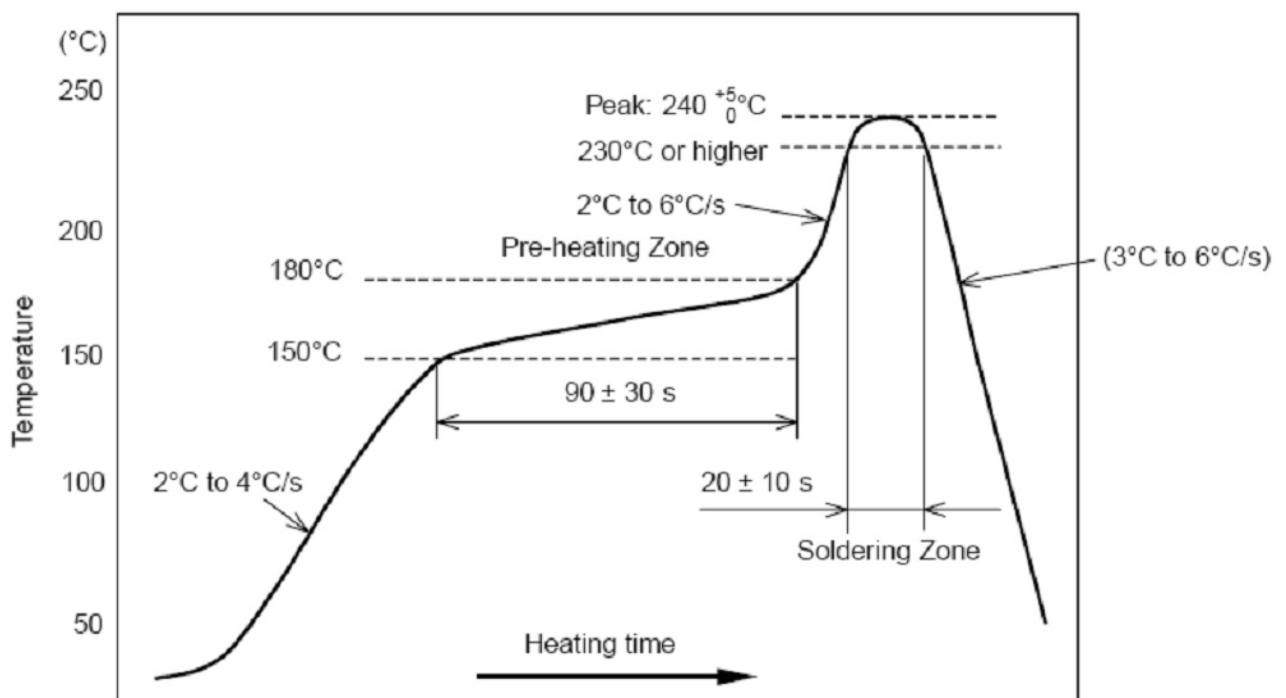

6.0 Reel and Tape dimensions

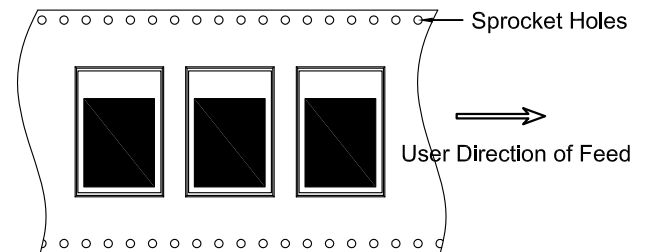
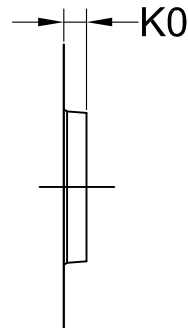
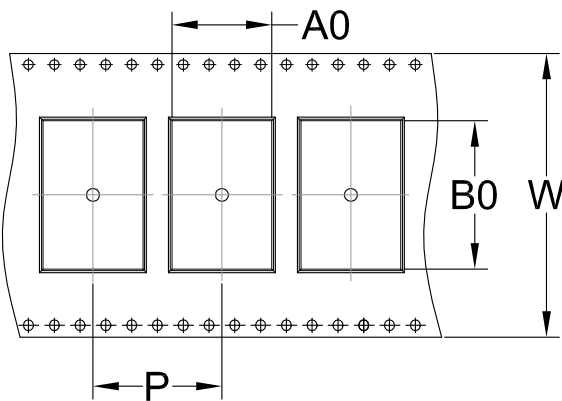
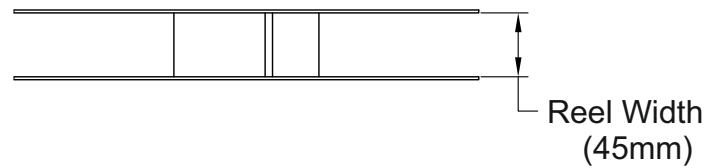
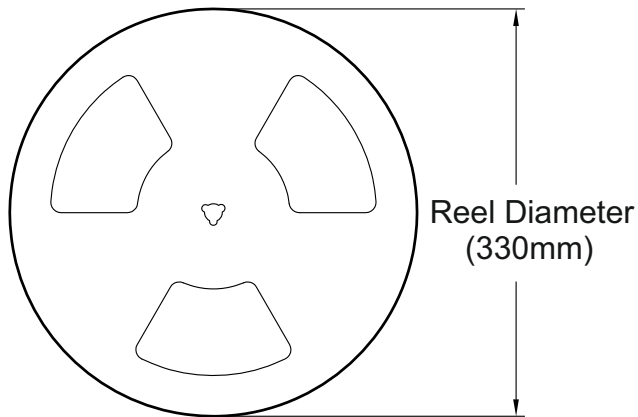

A0	Dimension designed to accommodate the component width	15.5mm ± 0.10mm
B0	Dimension designed to accommodate the component length	23.0mm ± 0.10mm
K0	Dimension designed to accommodate the component thickness	3.5mm ± 0.10mm
W	Overall width of the carrier tape	44.0mm ± 0.30mm
P	Pitch between successive cavity centers	20.0mm ± 0.10mm