



Automotive NJG1187AKGC-A GNSS High Gain Low Noise Amplifier

FEATURES

- AEC-Q100 grade 2
- Supply voltage 3.3 V typ.
- Low current consumption 8 mA typ.
- High gain
 - 34 dB typ. @ L1 band
 - 37 dB typ. @ L2/5 band
 - 36 dB typ. @ L6 band
- Low noise figure
 - 0.60 dB typ. @ L1 band
 - 0.65 dB typ. @ L2/5/6 band
- Package with wettable flank
 - 1.6 x 1.6 x 0.78 mm typ., pin pitch 0.5 mm
- RoHS compliant and Halogen Free, MSL1

GENERAL DESCRIPTION

The NJG1187AKGC-A is a high gain low noise amplifier (LNA) designed for GNSS applications. The NJG1187AKGC-A is available to be tuning for L1 (1.5 GHz) or L2/5/6 (1.1 to 1.2 GHz) bands by changing only value of external parts. Its wide operating temperature range from -40 to +105°C is suitable for automotive applications. Integrated ESD protection device on each port achieves excellent ESD robustness. ESON6-GC package with wettable flank structure is adopted for Automated Optical Inspection (AOI) of solder joint.

APPLICATIONS

- GNSS receive application for automotive
- Active antenna, dashboard camera, and navigation
- GNSS module

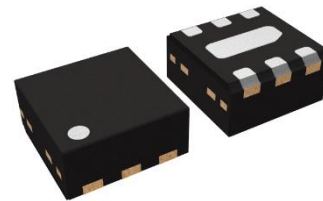

ESON6-GC
(1.6 x 1.6 x 0.78 mm)

BLOCK DIAGRAM

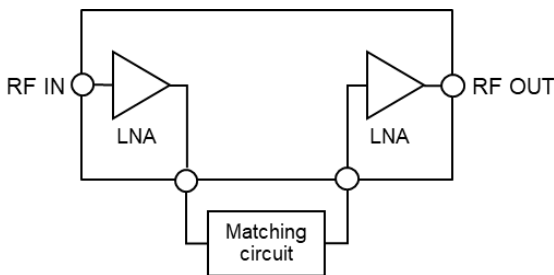

APPLICATION EXAMPLE

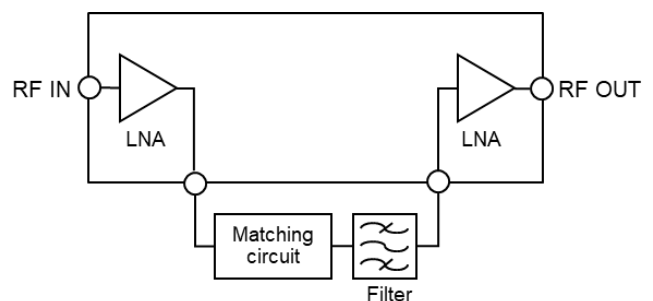

■ PRODUCT NAME INFORMATION

NJG1187A KGC -A (TE3)

Description of configuration

Suffix	Parameter	Description
KGC	Package code	Indicating the package. Refer to the order information for detail.
-A	Grade	Indicating the quality grade.
(TE3)	Packing	Refer to the packing specifications for detail.

Grade

Suffix	Applications	Operating Temperature Range	Test Temperature
-A	Chassis, Body control and In-vehicle	-40°C to 105°C	25°C, 105°C

■ ORDER INFORMATION

PRODUCT NAME	PACKAGE	RoHS	HALOGEN-FREE	PLATING COMPOSITION	MARKING	WEIGHT (mg)	Quantity per Reel (pcs)
NJG1187AKGC-A	ESON6-GC	Yes	Yes	SnBi	1187A A	5.4	3,000

■ PIN DESCRIPTIONS

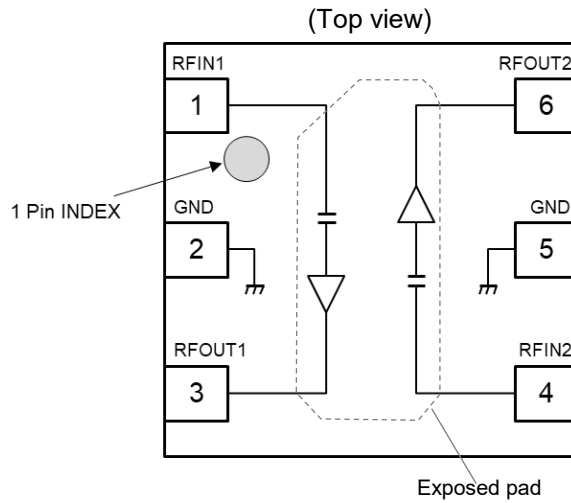

ESON6-GC Pin Configuration

Pin No.	Pin Name	Description
1	RFIN1	RF input terminal to 1st amp.
2	GND	Ground terminal
3	RFOUT1	RF output from 1st amp. and voltage supply terminal
4	RFIN2	RF input terminal to 2nd amp.
5	GND	Ground terminal
6	RFOUT2	RF output from 2nd amp. and voltage supply terminal
Exposed pad	-	Ground terminal

Please refer to "APPLICATION CIRCUIT" for details.

■ ABSOLUTE MAXIMUM RATINGS

$T_a = +25^{\circ}\text{C}$, $Z_s = Z_l = 50 \Omega$

Parameter	Symbol	Ratings	Unit
Supply voltage	V_{DD}	5.0	V
Input power	$P_{IN}^{(1)}$	+15	dBm
Power dissipation	$P_D^{(2)}$	1100	mW
Operating temperature	T_{opr}	-40 to +105	$^{\circ}\text{C}$
Storage temperature	T_{stg}	-55 to +150	$^{\circ}\text{C}$

(1): $V_{DD} = 3.3 \text{ V}$

(2): 4-layer FR4 PCB with through-hole (101.5 x 114.5 mm), $T_j = 150^{\circ}\text{C}$

ABSOLUTE MAXIMUM RATINGS

Electronic and mechanical stress momentarily exceeded absolute maximum ratings may cause permanent damage and may degrade the lifetime and safety for both device and system using the device in the field. The functional operation at or over these absolute maximum ratings is not assured.

*1 Please calculate the power consumption of the IC from the operating conditions, and calculate the junction temperature with the thermal resistance.

Please refer to "Thermal characteristics" for the thermal resistance under our measurement board conditions.

■ THERMAL CHARACTERISTICS

Parameter	Measurement Result
Thermal Resistance (θ_{ja})	$\theta_{ja} = 116^{\circ}\text{C/W}$
Thermal Characterization Parameter (ψ_{jt})	$\psi_{jt} = 43^{\circ}\text{C/W}$

θ_{ja} : Junction-to-Ambient Thermal Resistance

ψ_{jt} : Junction-to-Top Thermal Characterization Parameter

■ ELECTROSTATIC DISCHARGE (ESD) PROTECTION VOLTAGE

Parameter	Conditions	Pin No.	Pin Name	Protection Voltage	
				Ground	I/O
HBM	HBM : C = 100 pF, R = 1.5 k Ω	1	RFIN1	$\pm 1750 \text{ V}$	$\pm 250 \text{ V}$
		2	GND	COM.	-
		3	RFOUT1	$\pm 2000 \text{ V}$	$\pm 1750 \text{ V}$
		4	RFIN2	$\pm 2000 \text{ V}$	$\pm 1750 \text{ V}$
		5	GND	COM.	-
		6	RFOUT2	$\pm 1500 \text{ V}$	$\pm 1500 \text{ V}$

Parameter	Conditions	Protection Voltage
CDM	Direct CDM	$\pm 2000 \text{ V}$

ELECTROSTATIC DISCHARGE RATINGS

The electrostatic discharge test is done based on JESD47.
In the HBM method, ESD is applied using the power supply pin and GND pin as reference pins.

■ RECOMMENDED OPERATING CONDITIONS

Parameter	Symbol	Ratings	Unit
Supply voltage	V_{DD}	1.5 to 3.7	V
Ambient Operating Temperature	T_a	-40 to 105	°C

RECOMMENDED OPERATING CONDITIONS

All of electronic equipment should be designed that the mounted semiconductor devices operate within the recommended operating conditions. The semiconductor devices cannot operate normally over the recommended operating conditions, even if when they are used over such conditions by momentary electronic noise or surge. And the semiconductor devices may receive serious damage when they continue to operate over the recommended operating conditions.

■ ELECTRICAL CHARACTERISTICS 1 (DC)

General conditions: $T_a = +25^{\circ}\text{C}$, with application circuit

Parameter	Symbol	Condition	MIN.	TYP.	MAX.	Unit
Supply voltage	V_{DD}		1.5	3.3	3.7	V
Operating current	I_{DD}	RF OFF, $V_{DD} = 3.3\text{ V}$	-	8.0	13.0	mA

■ Electrical characteristics 2 (RF)

General conditions: $V_{DD} = 3.3\text{ V}$, $f_{RF} = 1559\text{ to }1610\text{ MHz}$, $T_a = +25^{\circ}\text{C}$, $Z_s = Z_l = 50\ \Omega$, with application circuit

Parameter	Symbol	Condition	MIN.	TYP.	MAX.	Unit
Small signal gain	Gain	$f = 1575\text{ MHz}$ (L1 band) Exclude PCB, Connector Losses (0.15 dB)	29.0	34.0	-	dB
Noise figure	NF	$f = 1575\text{ MHz}$ (L1 band) Exclude PCB, Connector Losses (0.08 dB)	-	0.60	1.15	dB
Isolation	ISL	$f = 1575\text{ MHz}$ (L1 band)	45.0	52.0	-	dB
Output power at 1 dB gain compression point	P-1dB(OUT)	$f = 1575\text{ MHz}$ (L1 band)	+7.0	+14.0	-	dBm
Output 3rd order intercept point	OIP3	$f_1 = 1575\text{ MHz}$, $f_2 = f_1 + 1\text{ MHz}$, $P_{IN} = -42\text{ dBm}$	+8.0	+16.0	-	dBm
RF IN return loss	RLi	$f = 1575\text{ MHz}$ (L1 band)	5	10	-	dB
RF OUT return loss	RLo	$f = 1575\text{ MHz}$ (L1 band)	7	18	-	dB

■ Electrical characteristics 3 (RF)

General conditions: $V_{DD} = 3.3\text{ V}$, $f_{RF} = 1164\text{ to }1300\text{ MHz}$, $T_a = +25^\circ\text{C}$, $Z_s = Z_l = 50\ \Omega$, with application circuit

Parameter	Symbol	Condition	MIN.	TYP.	MAX.	Unit
Small signal gain	Gain	f = 1176 MHz (L5 band) Exclude PCB, Connector Losses (0.10 dB)	33.0	37.0	-	dB
		f = 1227 MHz (L2 band) Exclude PCB, Connector Losses (0.10 dB)	32.5	37.0	-	
		f = 1278 MHz (L6 band) Exclude PCB, Connector Losses (0.11 dB)	31.0	36.0	-	
Noise figure	NF	f = 1176 MHz (L5 band) Exclude PCB, Connector Losses (0.05 dB)	-	0.65	1.05	dB
		f = 1227 MHz (L2 band) Exclude PCB, Connector Losses (0.06 dB)	-	0.65	1.05	
		f = 1278 MHz (L6 band) Exclude PCB, Connector Losses (0.06 dB)	-	0.65	1.05	
Isolation	ISL	f = 1176 MHz (L5 band)	44.5	50.0	-	dB
		f = 1227 MHz (L2 band)	44.5	50.0	-	
		f = 1278 MHz (L6 band)	44.5	50.5	-	
Output power at 1 dB Gain compression point	P-1dB(OUT)	f = 1176 MHz (L5 band)	+7.0	+13.0	-	dBm
		f = 1227 MHz (L2 band)	+7.0	+13.0	-	
		f = 1278 MHz (L6 band)	+7.0	+13.0	-	
Output 3rd order intercept point	OIP3	f1 = 1176 MHz, f2 = f1 + 1 MHz, $P_{IN} = -42\text{ dBm}$	+9.0	+19.0	-	dBm
		f1 = 1227 MHz, f2 = f1 + 1 MHz, $P_{IN} = -42\text{ dBm}$	+11.0	+19.0	-	
		f1 = 1278 MHz, f2 = f1 + 1 MHz, $P_{IN} = -42\text{ dBm}$	12.5	+18.0	-	
RF IN return loss	RLi	f = 1176 MHz (L5 band)	4	15	-	dB
		f = 1227 MHz (L2 band)	5	15	-	
		f = 1278 MHz (L6 band)	6	12	-	
RF OUT return loss	RLo	f = 1176 MHz (L5 band)	7	12	-	dB
		f = 1227 MHz (L2 band)	7	15	-	
		f = 1278 MHz (L6 band)	7	17	-	

■ TYPICAL CHARACTERISTICS (L1 band application)

Conditions: $V_{DD} = 3.3\text{ V}$, $T_a = 25^\circ\text{C}$, $Z_s = Z_l = 50\ \Omega$, with application circuit

(Typical Characteristics are intended to be used as reference data; they are not guaranteed.)

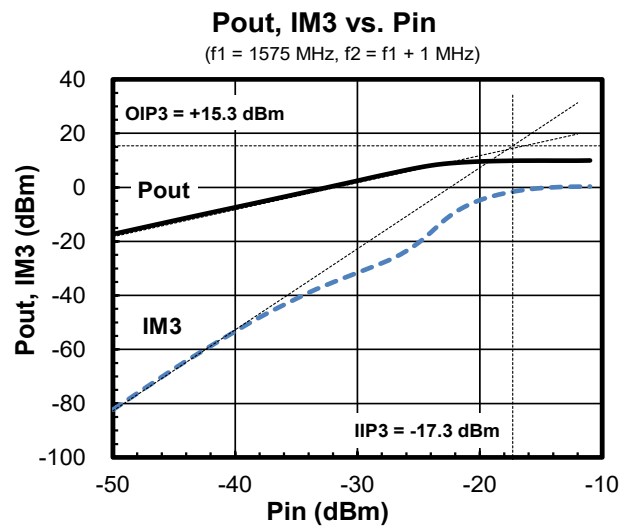
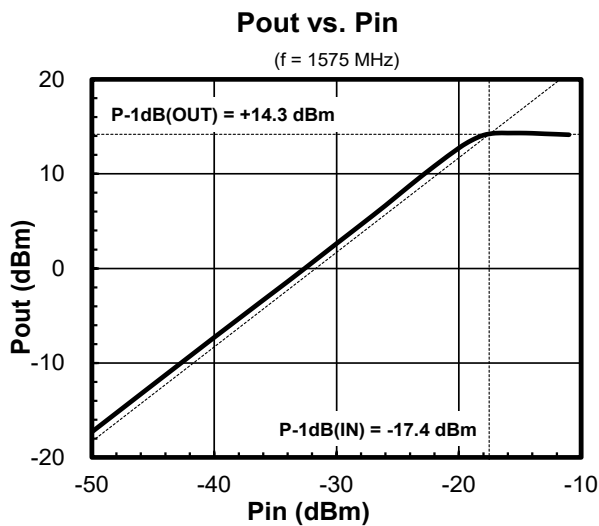
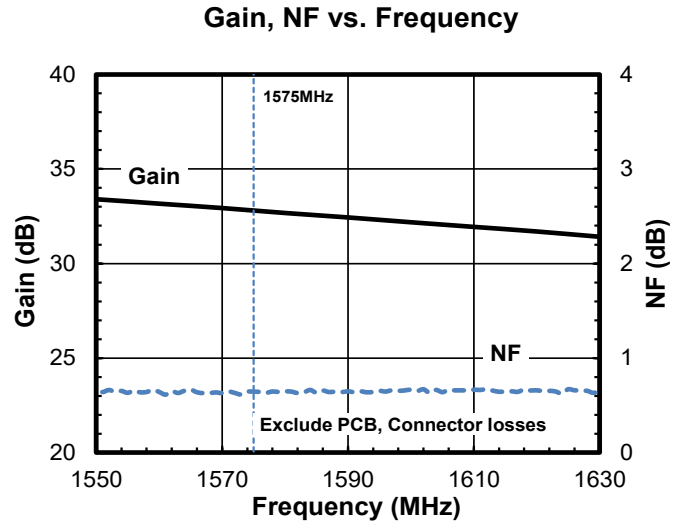
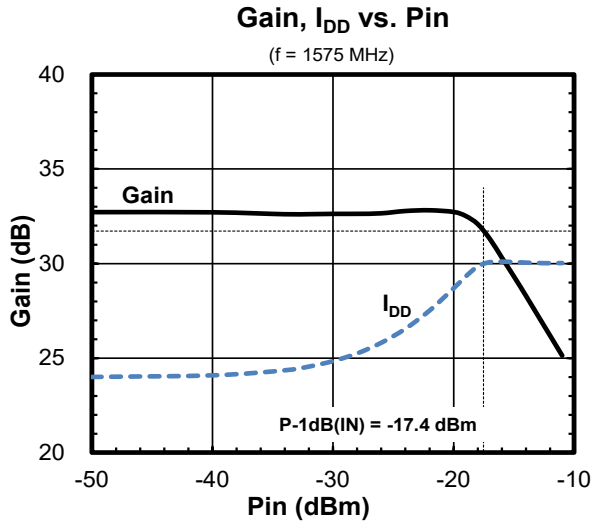

■ TYPICAL CHARACTERISTICS (L1 band application)

Conditions: $V_{DD} = 3.3\text{ V}$, $T_a = 25^\circ\text{C}$, $Z_s = Z_l = 50\ \Omega$, with application circuit

(Typical Characteristics are intended to be used as reference data; they are not guaranteed.)

S11 vs. Frequency

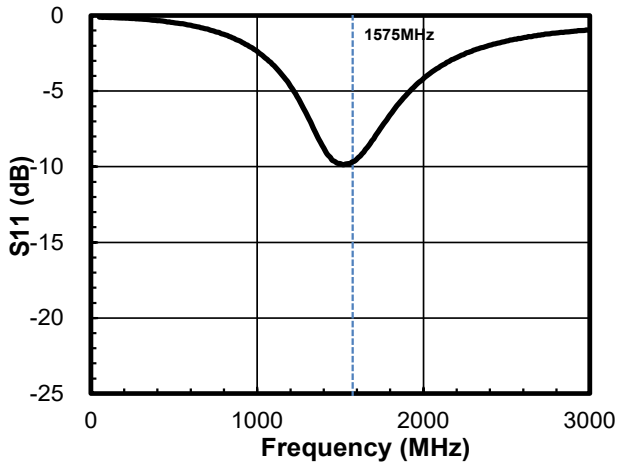

S21 vs. Frequency

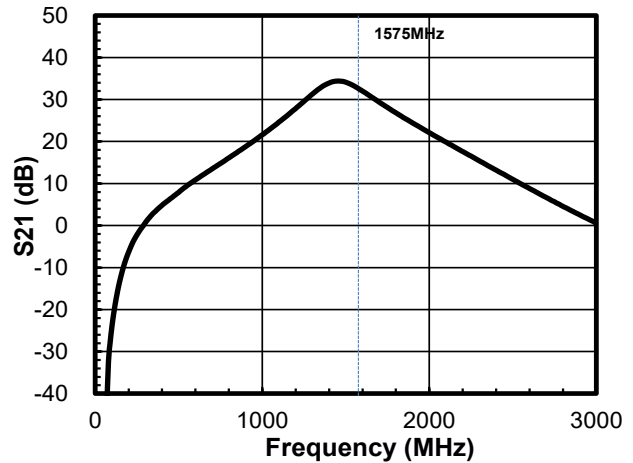

S22 vs. Frequency

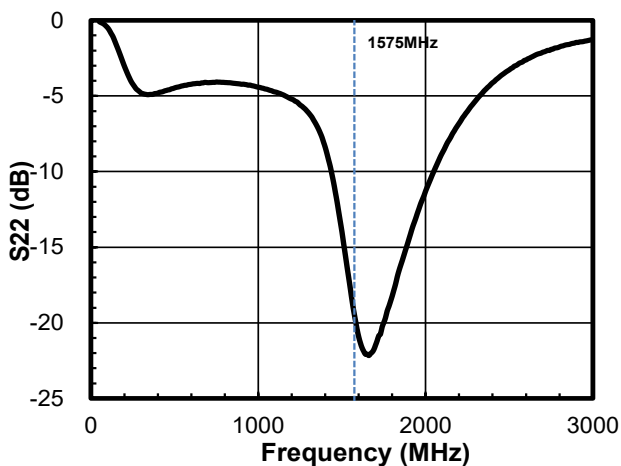

S12 vs. Frequency

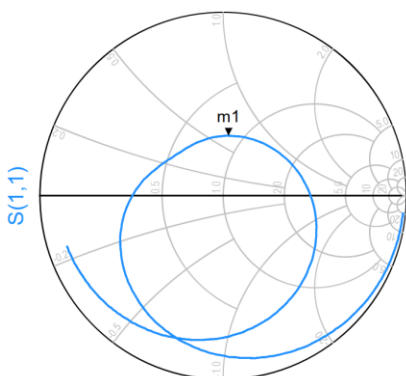
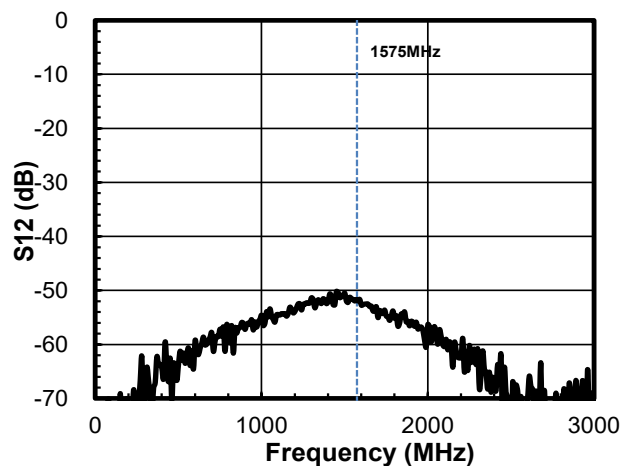

freq (50.00MHz to 3.000GHz)

m1
freq=1.575GHz
S(1,1)=0.329 / 84.893
impedance = $Z_0 * (0.850 + j0.624)$

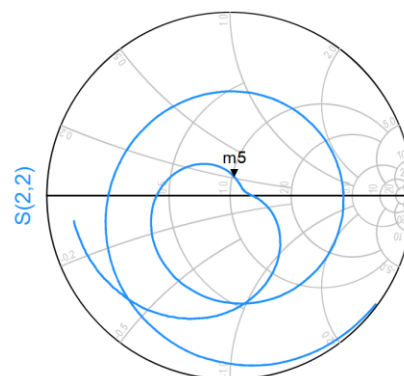

freq (50.00MHz to 3.000GHz)

m5
freq=1.575GHz
S(2,2)=0.106 / 77.172
impedance = $Z_0 * (1.026 + j0.214)$

■ TYPICAL CHARACTERISTICS (L1 band application)

Conditions: $V_{DD} = 3.3\text{ V}$, $T_a = 25^\circ\text{C}$, $Z_s = Z_l = 50\ \Omega$, with application circuit

(Typical Characteristics are intended to be used as reference data; they are not guaranteed.)

S11 vs. Frequency

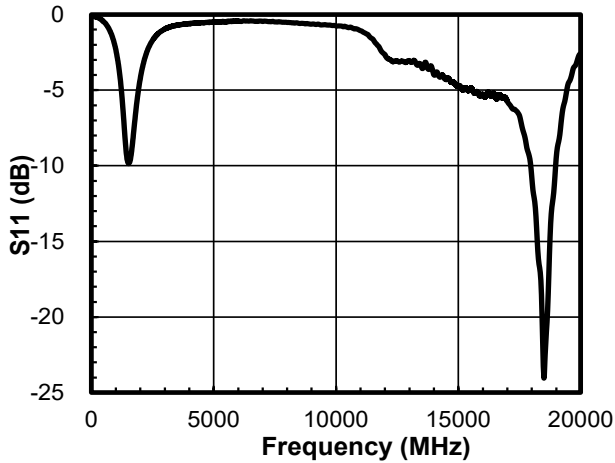

S21 vs. Frequency

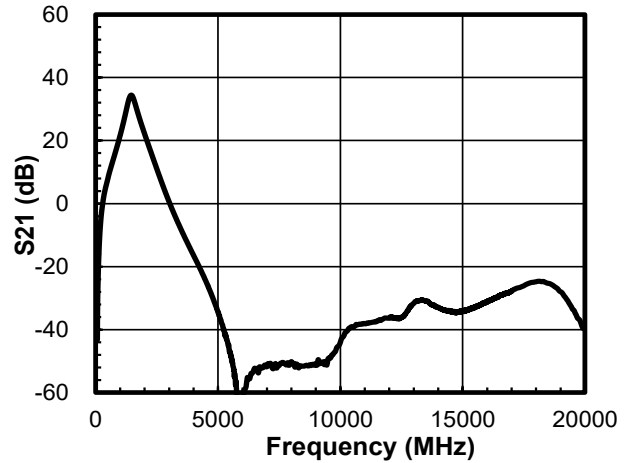

S22 vs. Frequency

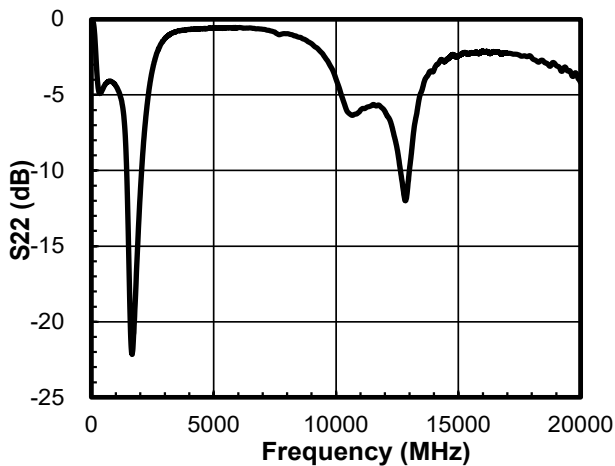

S12 vs. Frequency

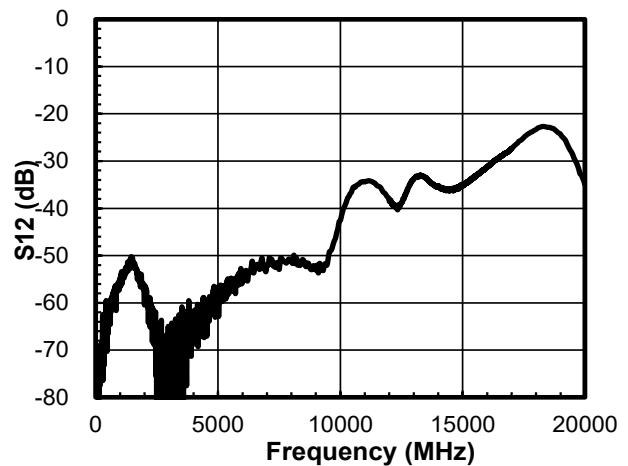

K factor vs. Frequency

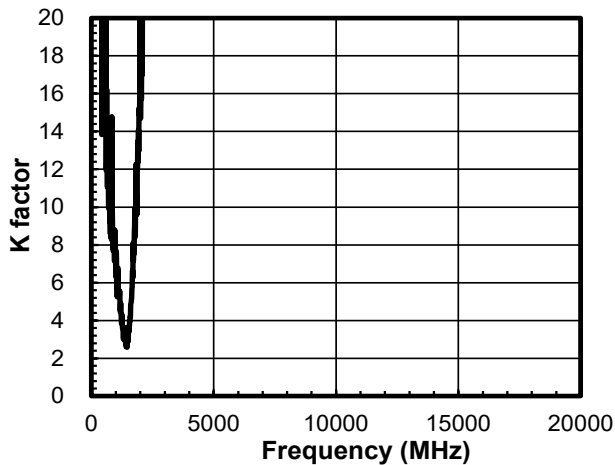

■ TYPICAL CHARACTERISTICS (L1 band application)

Conditions: $T_a = 25^\circ\text{C}$, $Z_s = Z_l = 50 \Omega$, with application circuit

(Typical Characteristics are intended to be used as reference data; they are not guaranteed.)

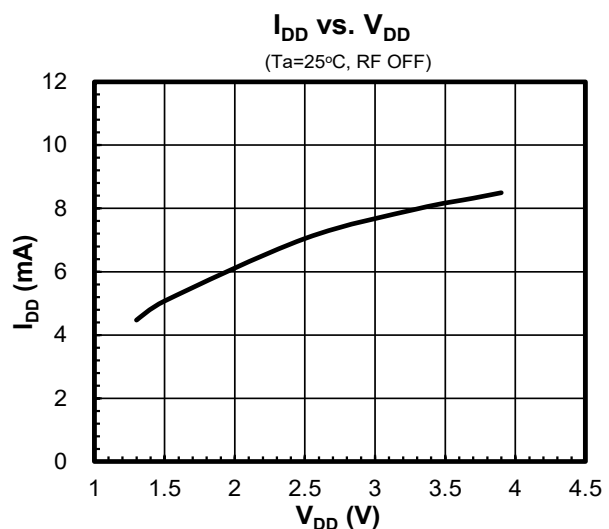
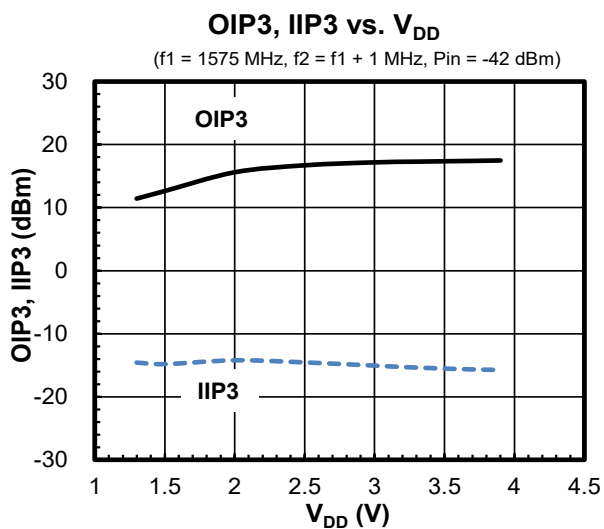
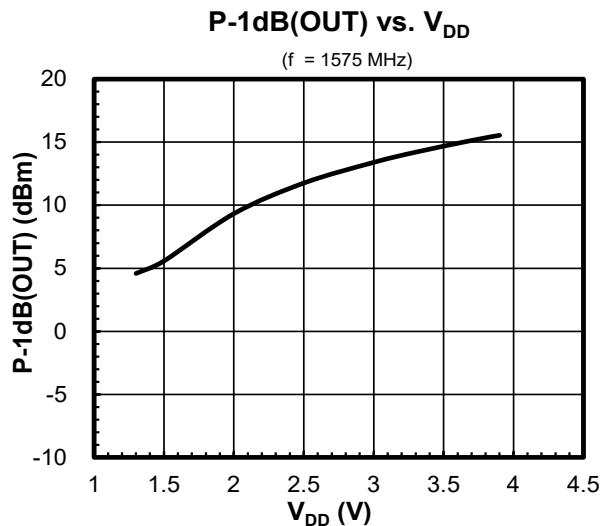
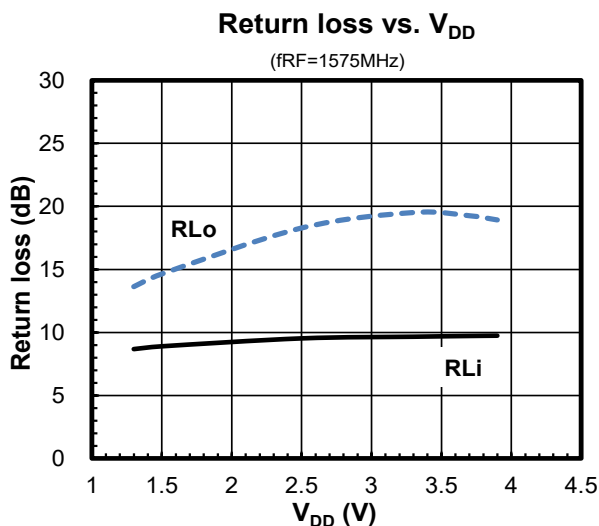
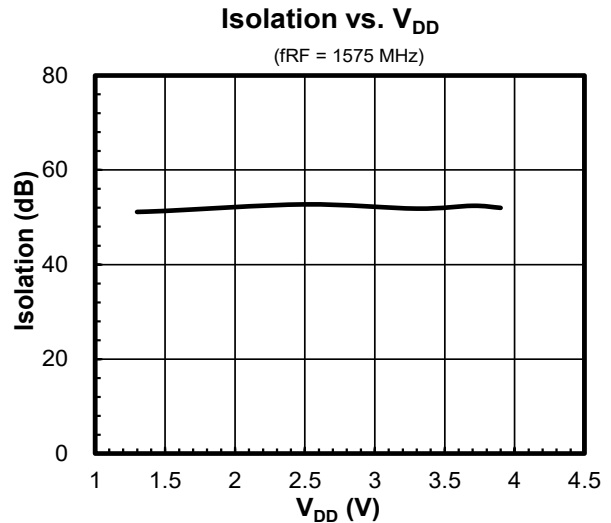
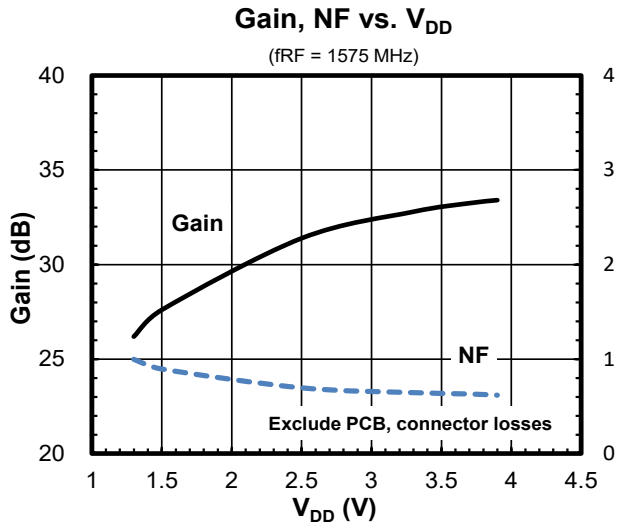

■ TYPICAL CHARACTERISTICS (L1 band application)

Conditions: $V_{DD} = 3.3\text{ V}$, $Z_s = Z_l = 50\ \Omega$, with application circuit

(Typical Characteristics are intended to be used as reference data; they are not guaranteed.)

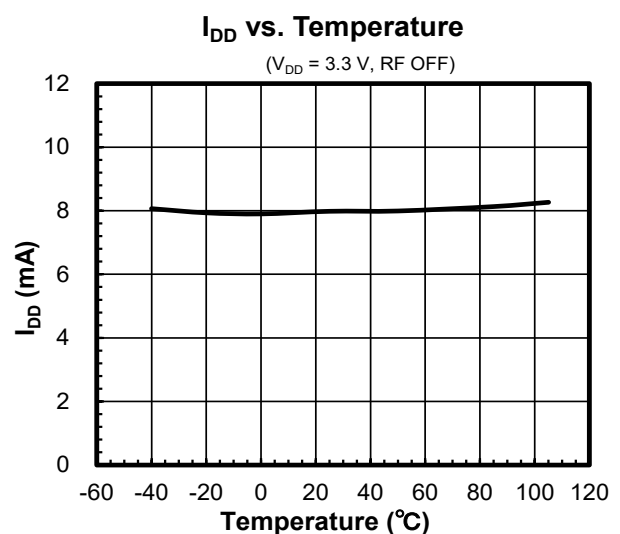
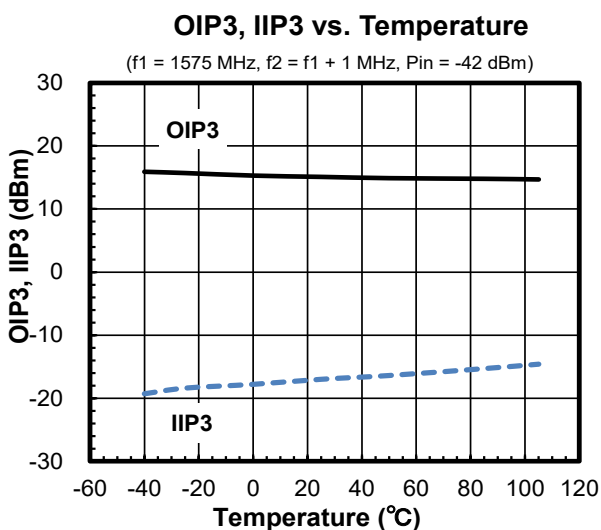
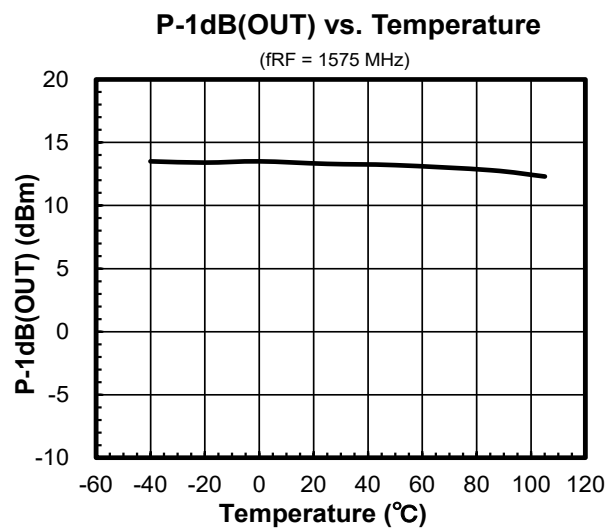
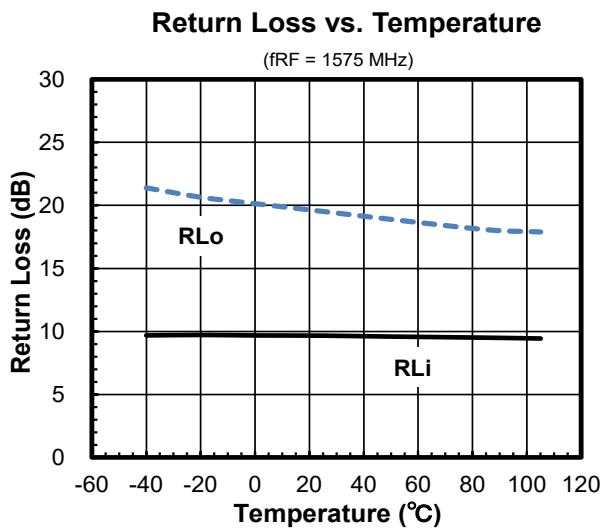
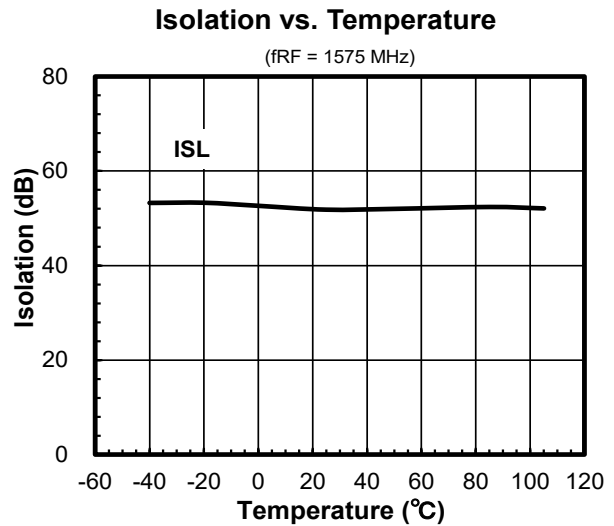
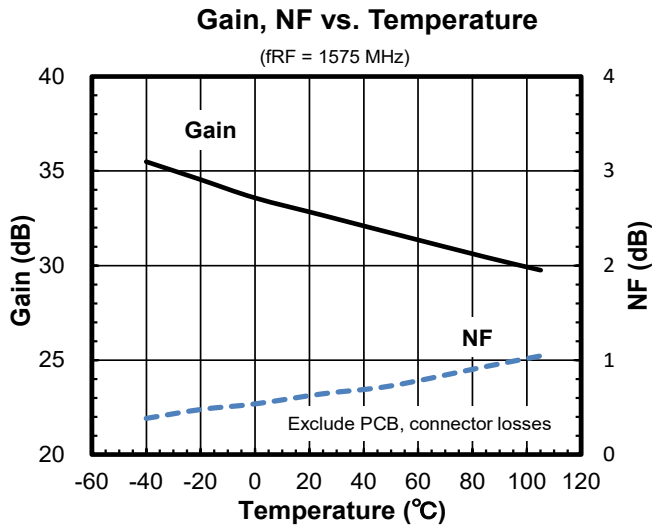

■ TYPICAL CHARACTERISTICS (L2/5/6 band application)

Conditions: $V_{DD} = 3.3\text{ V}$, $T_a = 25^\circ\text{C}$, $Z_s = Z_l = 50\ \Omega$, with application circuit

(Typical Characteristics are intended to be used as reference data; they are not guaranteed.)

Gain, I_{DD} vs. Pin

(f = 1227 MHz)

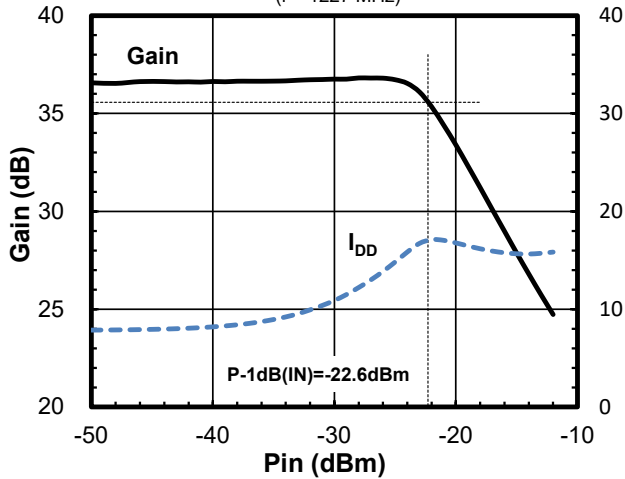

Gain, NF vs. Frequency

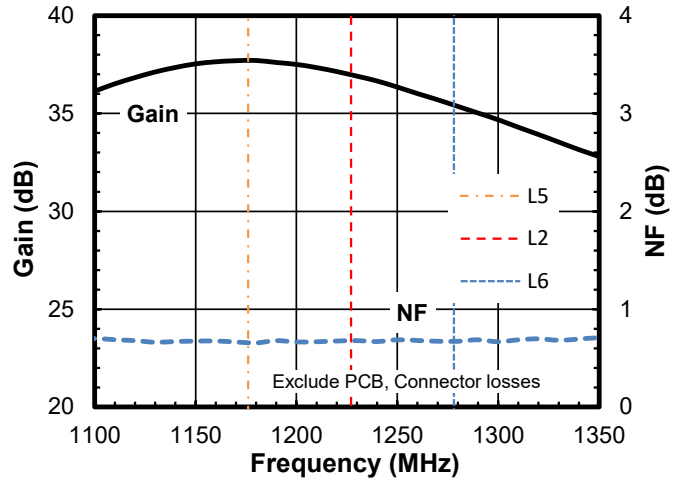

Pout vs. Pin

(f = 1227 MHz)

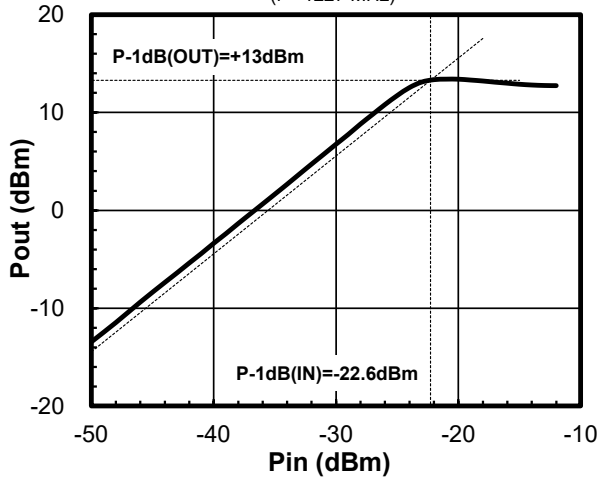

Pout, IM3 vs. Pin

(f1 = 1227 MHz, f2 = f1 + 1 MHz)

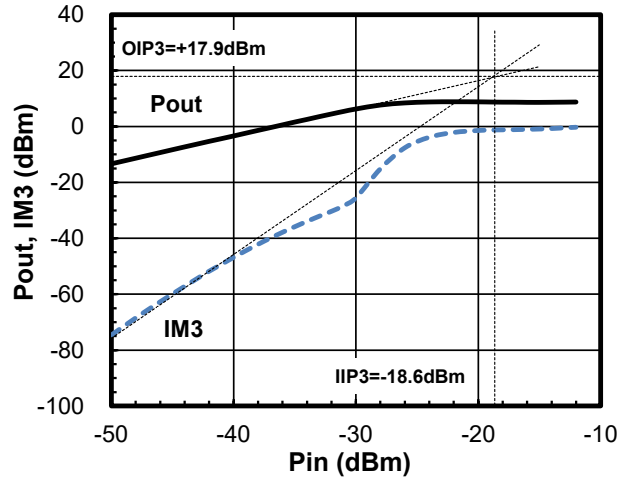

P-1dB(OUT) vs. Frequency

(f = 1176 to 1278 MHz)

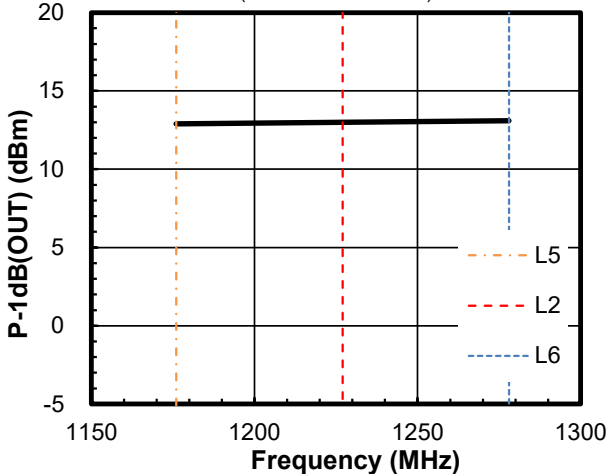

IIP3, OIP3 vs. Frequency

(f1 = 1176 to 1278 MHz, f2 = f1 + 1 MHz, Pin = -42 dBm)

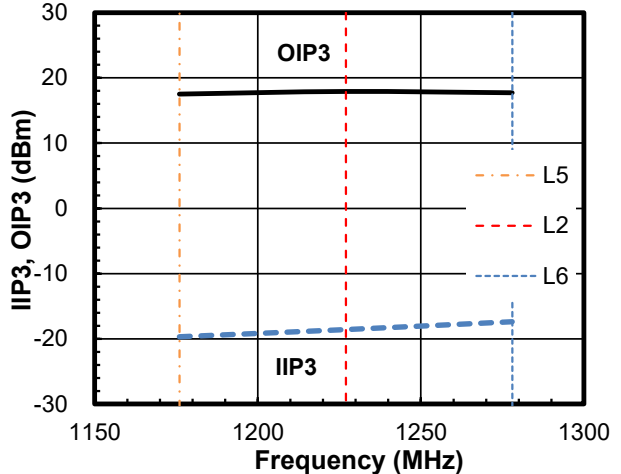

■ TYPICAL CHARACTERISTICS (L2/5/6 band application)

Conditions: $V_{DD} = 3.3\text{ V}$, $T_a = 25^\circ\text{C}$, $Z_s = Z_l = 50\ \Omega$, with application circuit

(Typical Characteristics are intended to be used as reference data; they are not guaranteed.)

S11 vs. Frequency

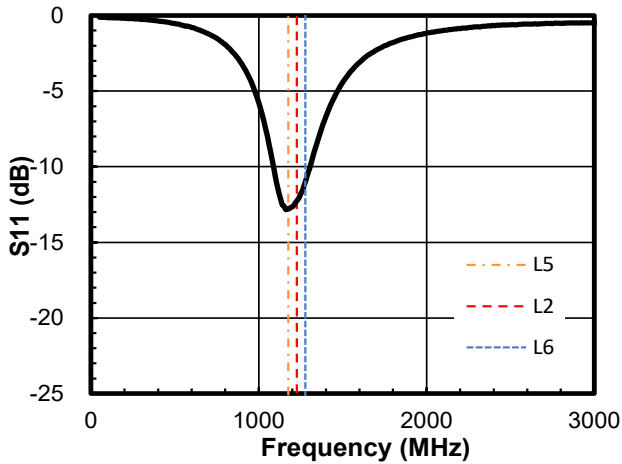

S21 vs. Frequency

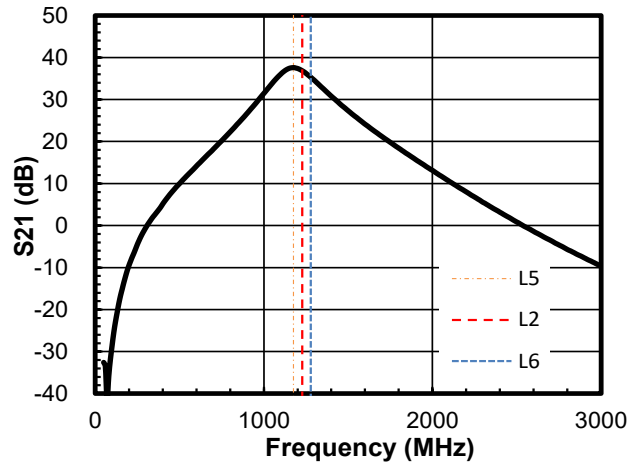

S22 vs. Frequency

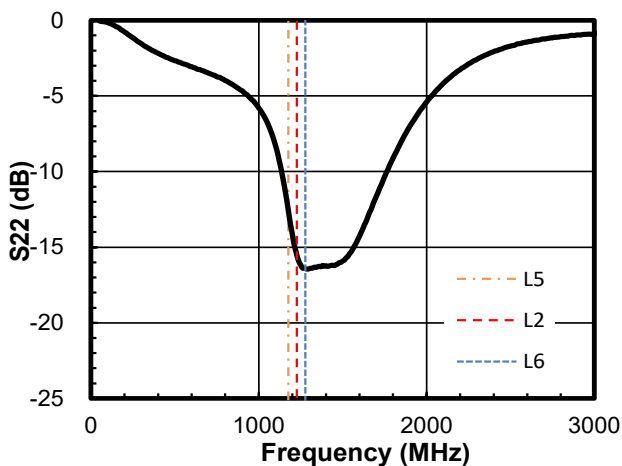

S12 vs. Frequency

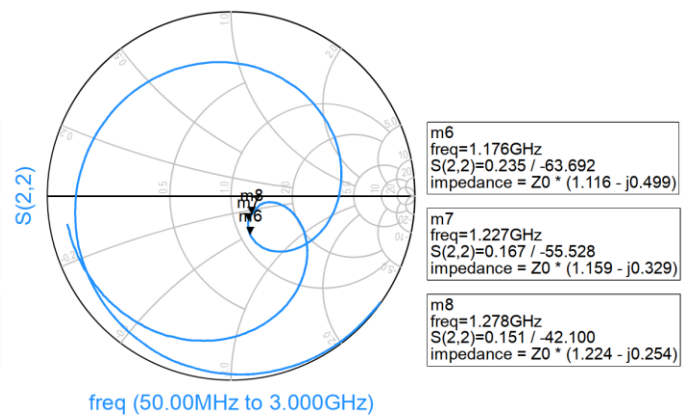
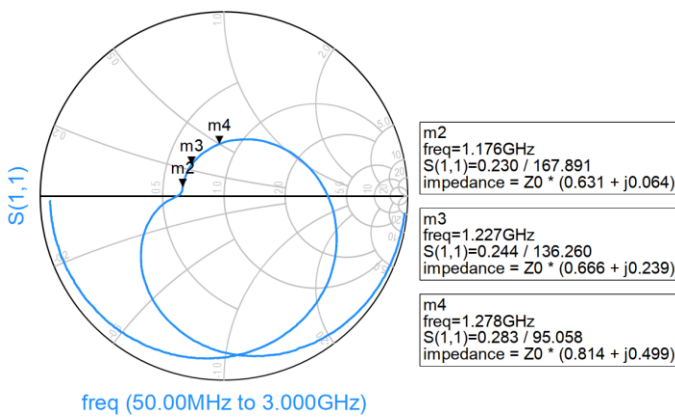
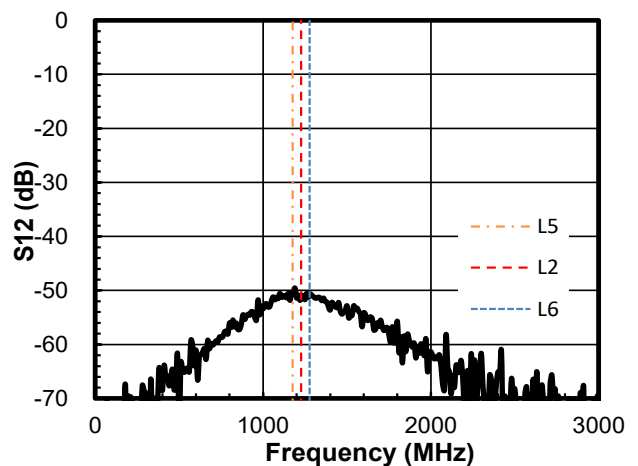

■ TYPICAL CHARACTERISTICS (L2/5/6 band application)

Conditions: $V_{DD} = 3.3\text{ V}$, $T_a = 25^\circ\text{C}$, $Z_s = Z_l = 50\ \Omega$, with application circuit

(Typical Characteristics are intended to be used as reference data; they are not guaranteed.)

S11 vs. Frequency

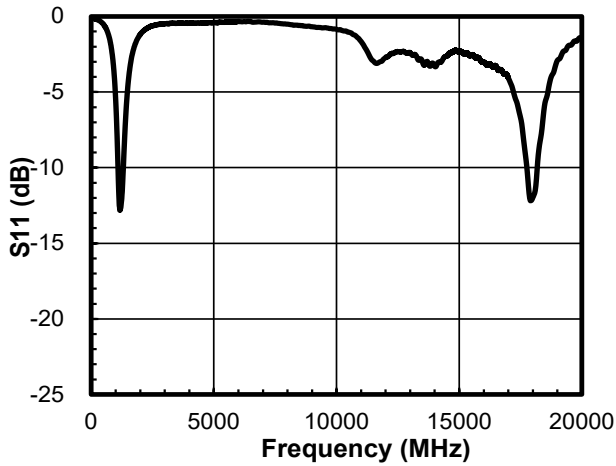

S21 vs. Frequency

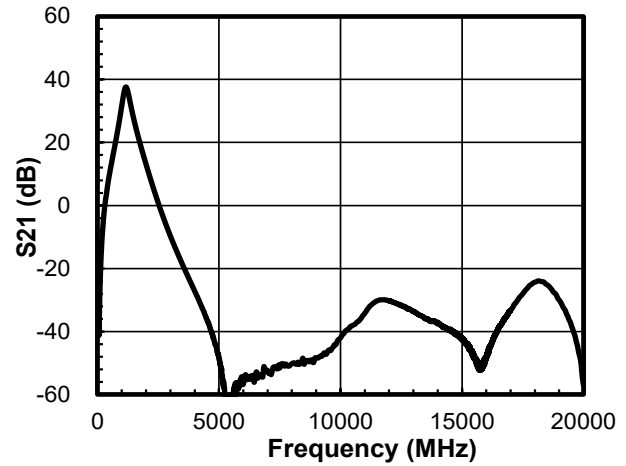

S22 vs. Frequency

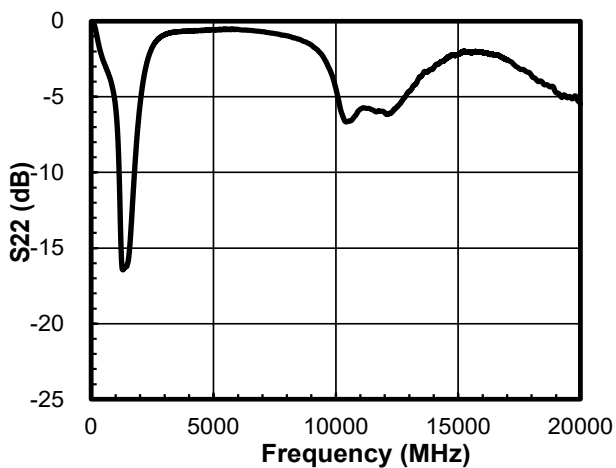

S12 vs. Frequency

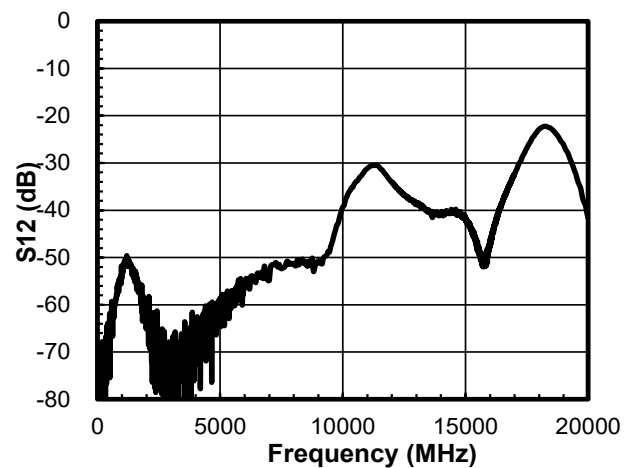

K factor vs. Frequency

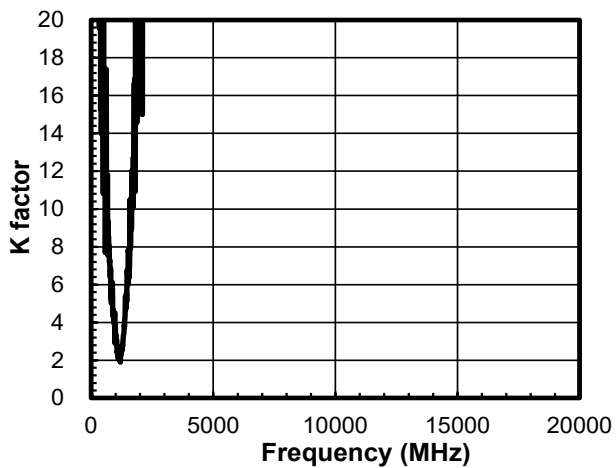

■ TYPICAL CHARACTERISTICS (L2/5/6 band application)

Conditions: $T_a = 25^\circ\text{C}$, $Z_s = Z_l = 50 \Omega$, with application circuit

(Typical Characteristics are intended to be used as reference data; they are not guaranteed.)

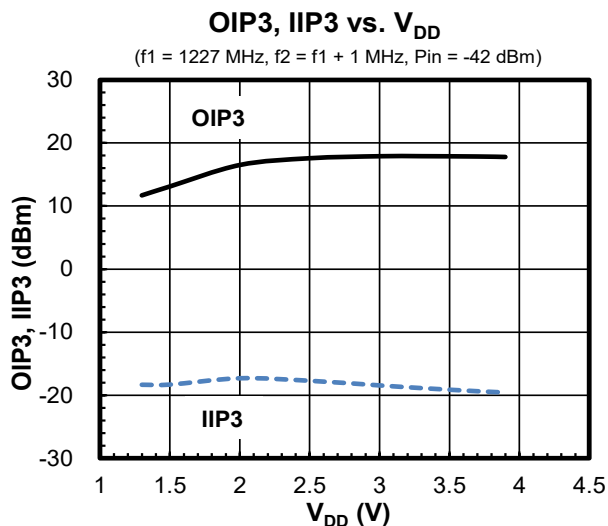
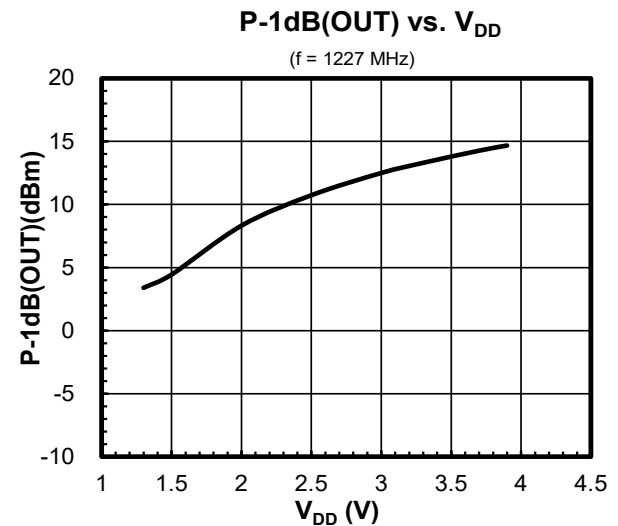
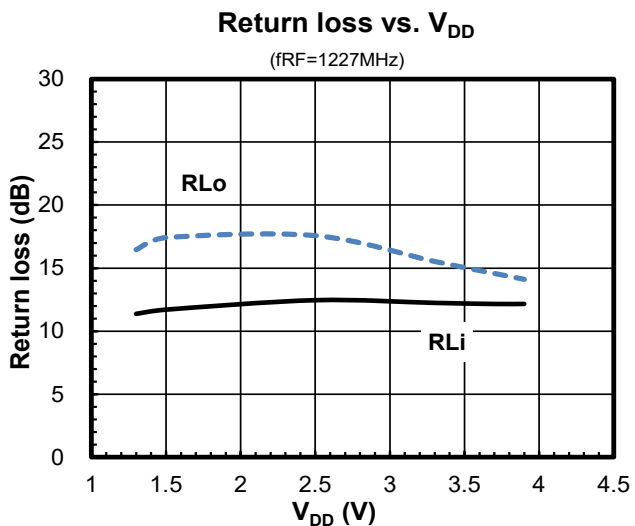
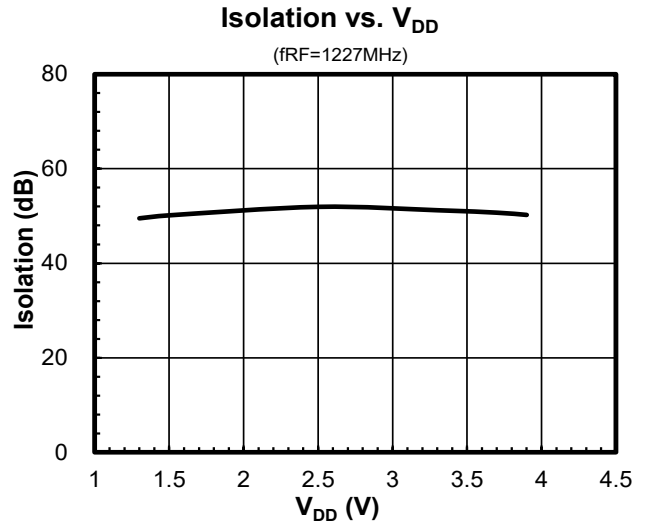
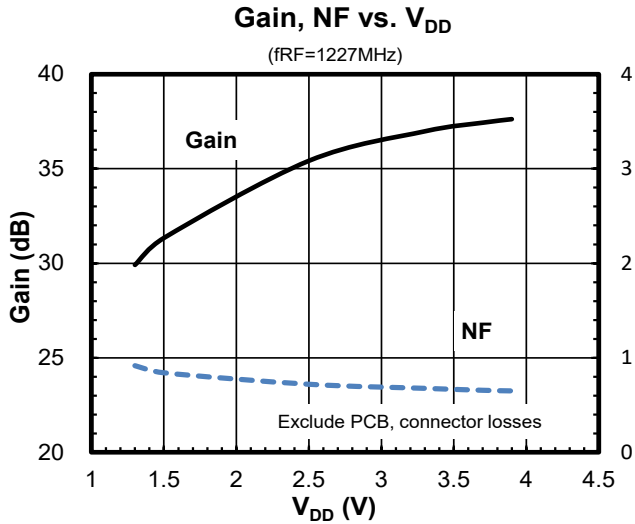

■ TYPICAL CHARACTERISTICS (L2/5/6 band application)

Conditions: $V_{DD} = 3.3\text{ V}$, $Z_s = Z_l = 50\ \Omega$, with application circuit

(Typical Characteristics are intended to be used as reference data; they are not guaranteed.)

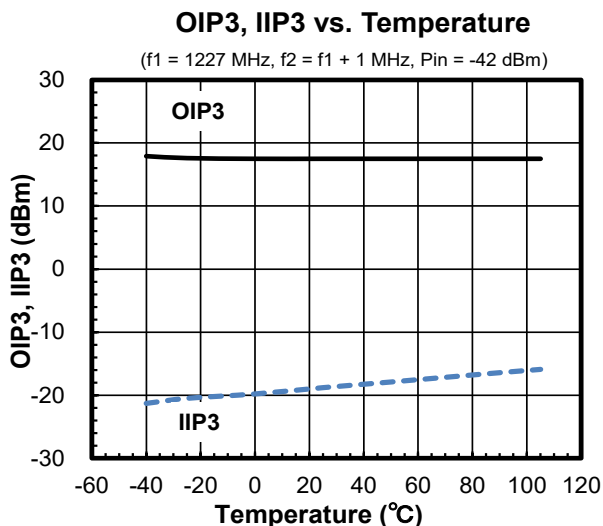
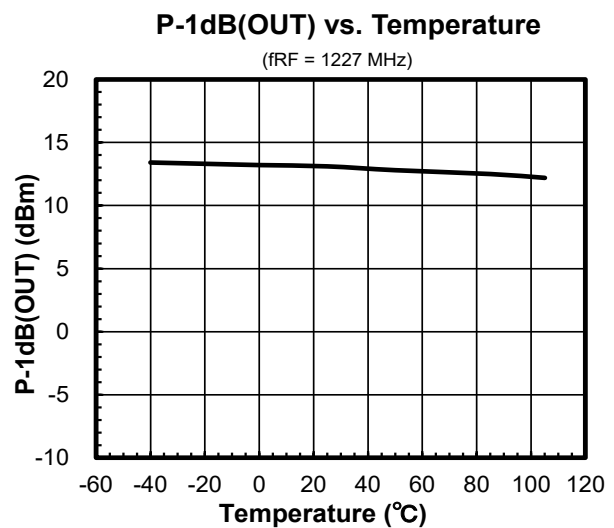
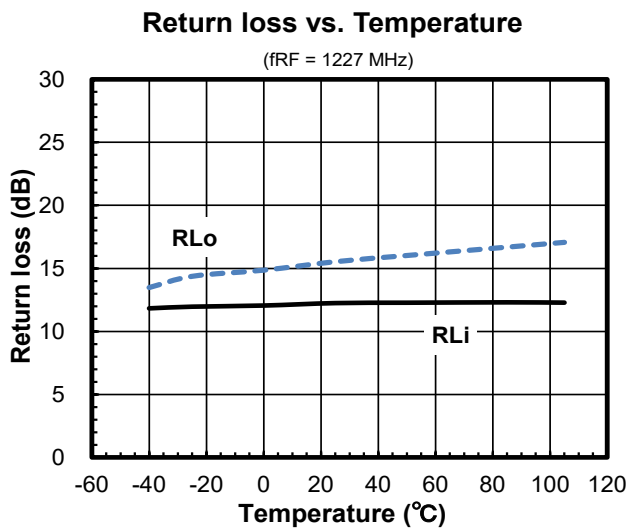
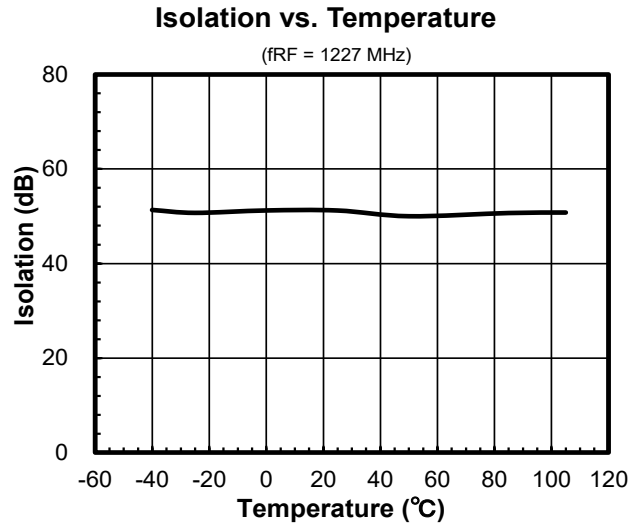
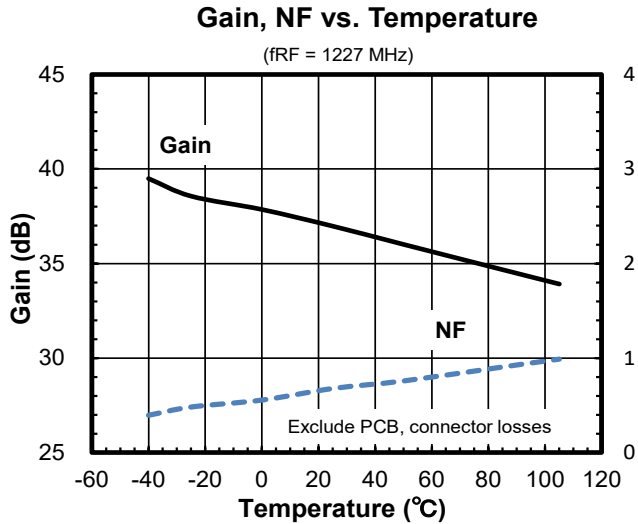

APPLICATION CIRCUIT

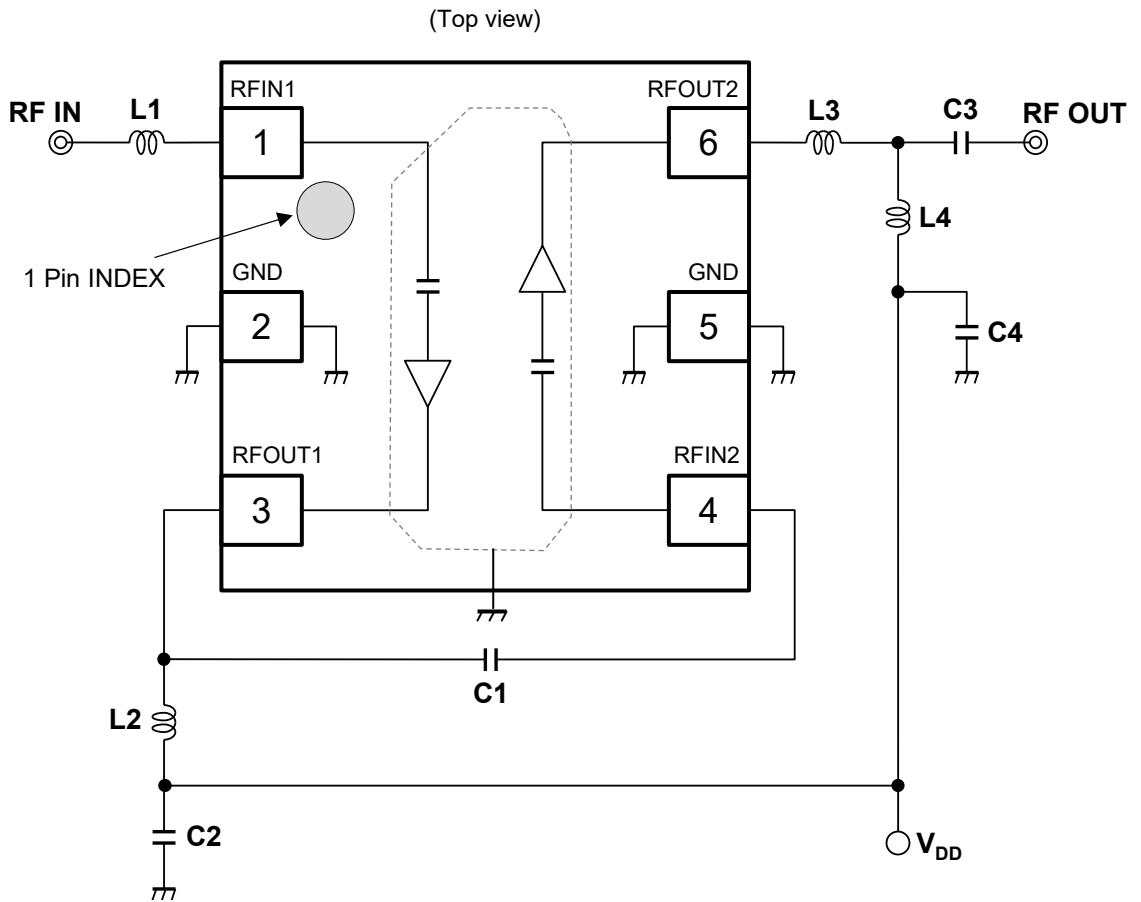

NJG1187AKGC-A Application Circuit

<PARTS LIST>

Part ID	Value		Notes
	1559 to 1610 MHz (L1 band)	1164 to 1300 MHz (L2/5/6 band)	
L1	10 nH	16 nH	LQW15AN_00 Series (MURATA)
L2	4.7 nH	8.2 nH	
L3	7.5 nH	9.1 nH	
L4	27 nH	12 nH	
C1	3.3 pF	2.2 pF	GRM03 Series (MURATA)
C2	4700 pF	4700 pF	
C3	18 pF	18 pF	
C4	4700 pF	4700 pF	

■ APPLICATION NOTES

● EVALUATION BOARD

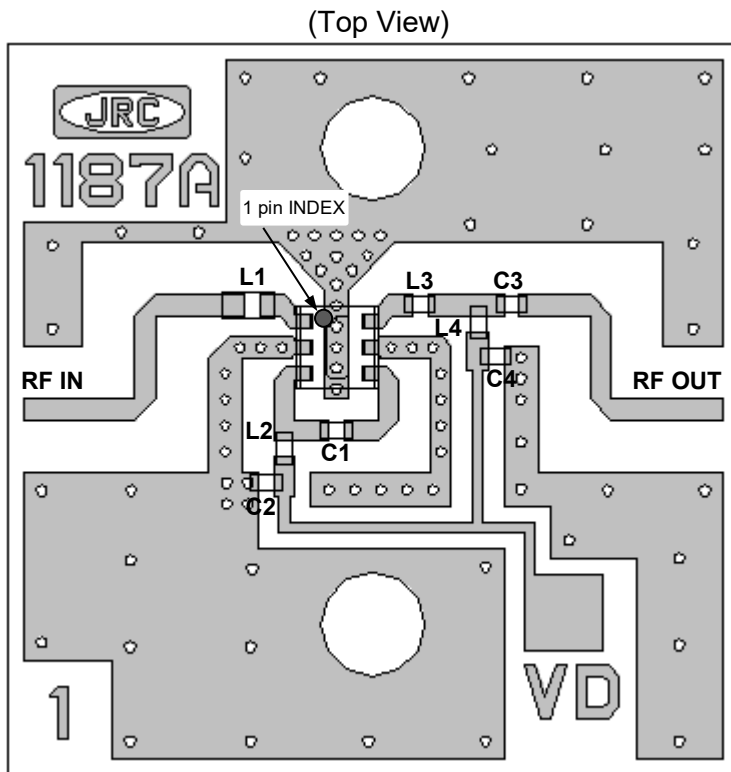

PCB

Substrate: FR-4

Thickness: 0.2 mm

Microstrip line width: 0.4 mm ($Z_0 = 50 \Omega$)

Size: 14.0 mm x 14.0 mm

<PCB LAYOUT GUIDELINE>

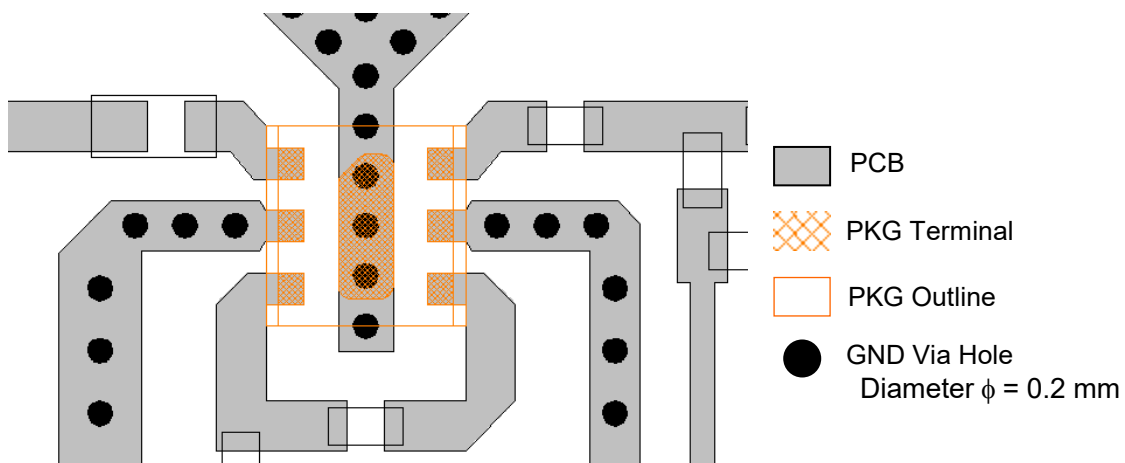

PRECAUTIONS

- All external parts should be placed as close as possible to the LNA.
- For good RF performance, all GND terminals must be connected to PCB ground plane of substrate, and via-holes for GND should be placed near the LNA.

● NF MEASUREMENT BLOCK DIAGRAM

Measuring instruments

NF Analyzer : Keysight N8973A

Noise Source : Keysight N4000A

Setting the NF analyzer

Measurement mode form

Device under test : Amplifier

System downconverter : off

Mode setup form

Sideband : LSB

Averages : 8

Average mode : Point

Bandwidth : 4 MHz

Loss comp : off

Tcold : setting the temperature of noise source (Auto)

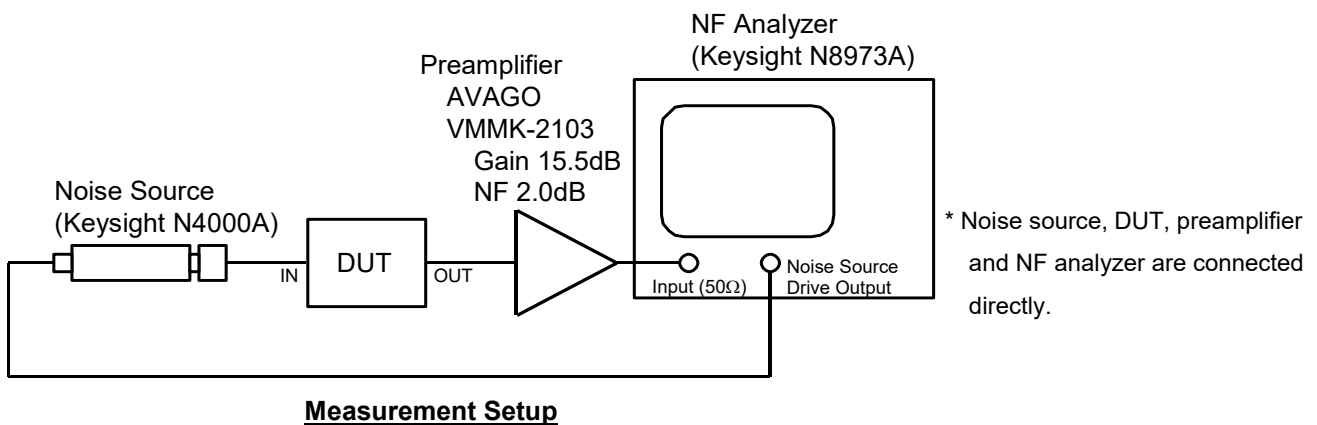
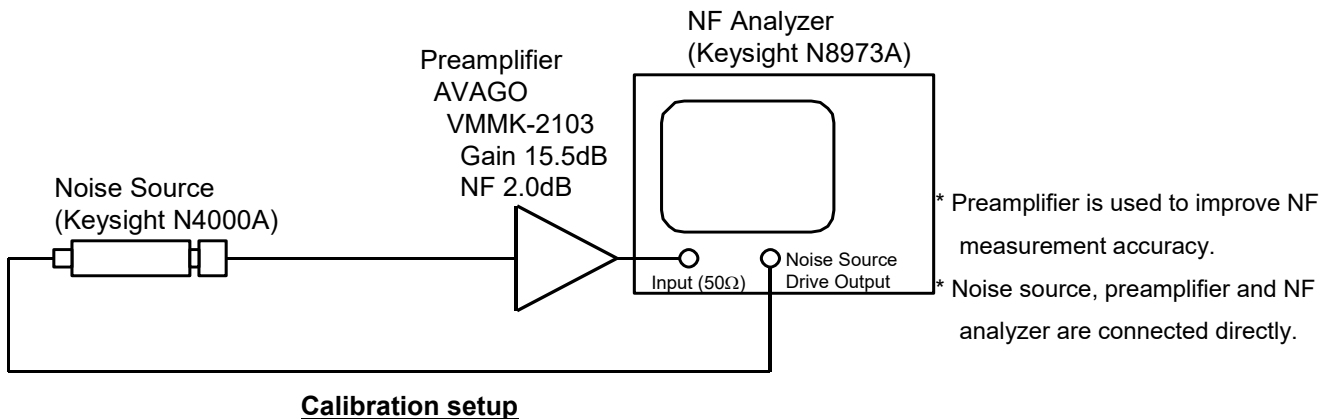

● REVISION HISTORY

Date	Revision	Changes
19.Apri.2023	Ver.1.0	Initial

Nisshinbo Micro Devices Inc.

DFN6-GC(ESON6-GC)

PI-DFN6-GC-E-B

■ PACKAGE DIMENSIONS

UNIT: mm

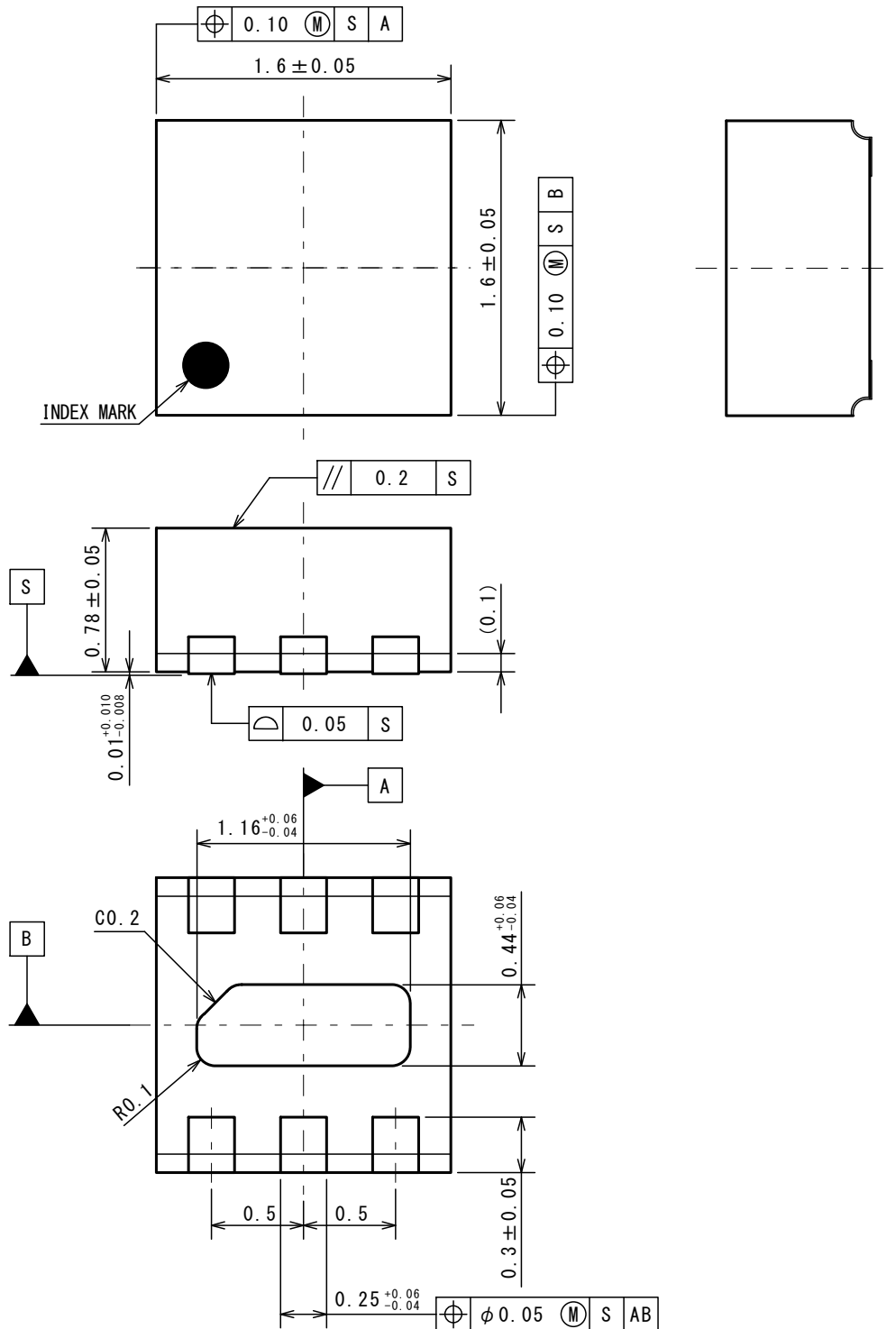

■ EXAMPLE OF SOLDER PADS DIMENSIONS

UNIT: mm

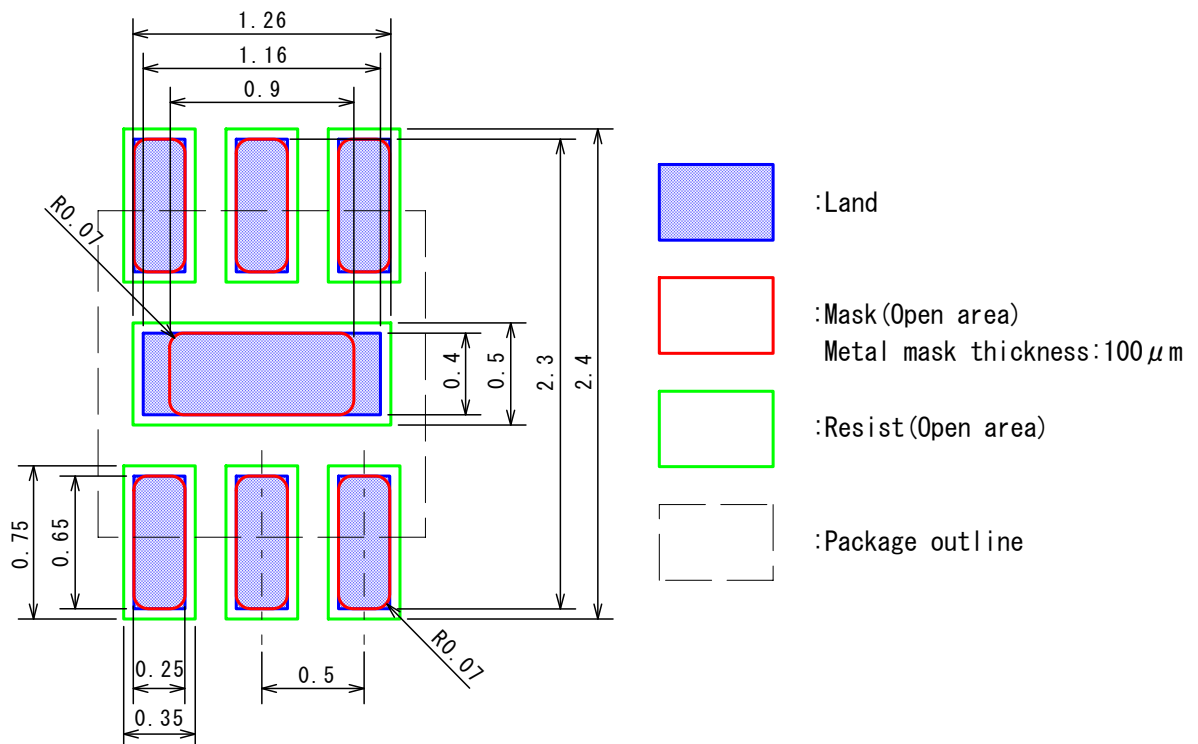

Nisshinbo Micro Devices Inc.

DFN6-GC(ESON6-GC)

PI-DFN6-GC-E-B

■ PACKING SPEC

UNIT: mm

(1) Taping dimensions / Insert direction

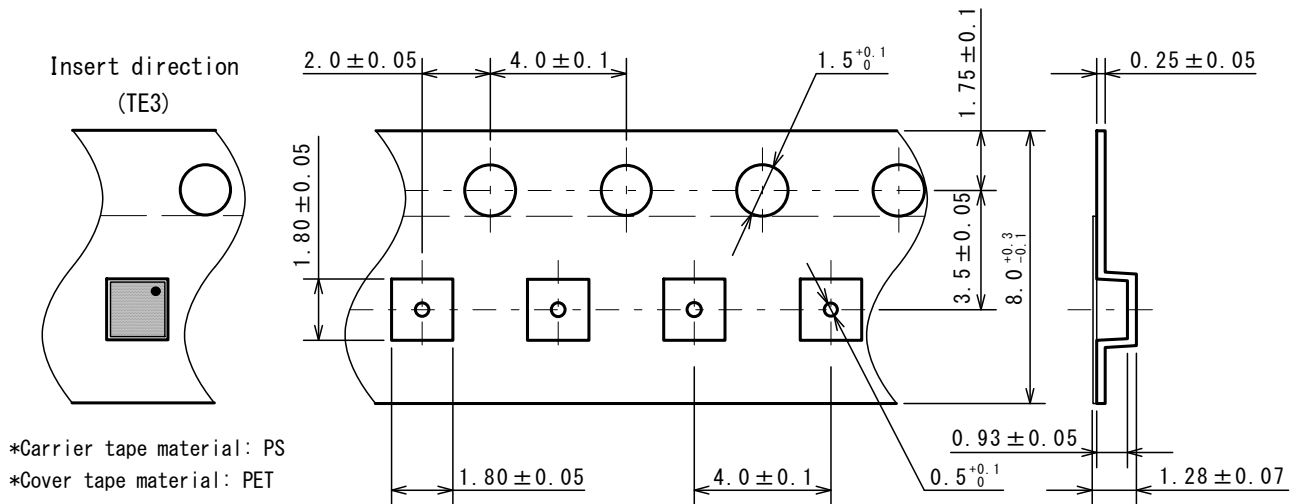

(2) Taping state

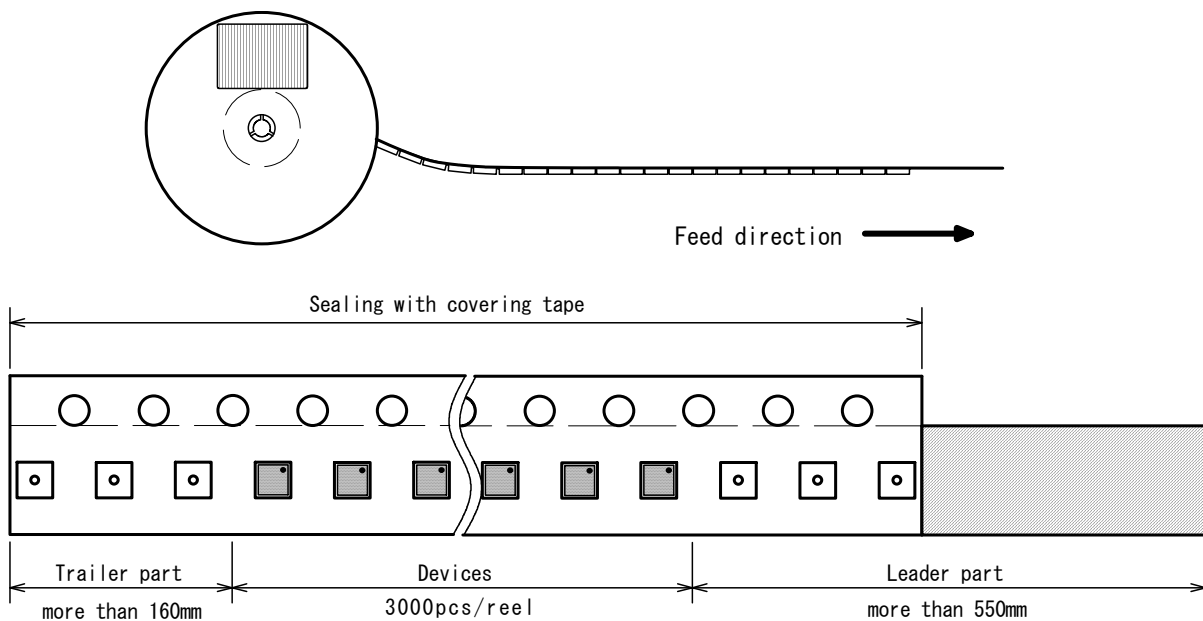

(3) Reel dimensions

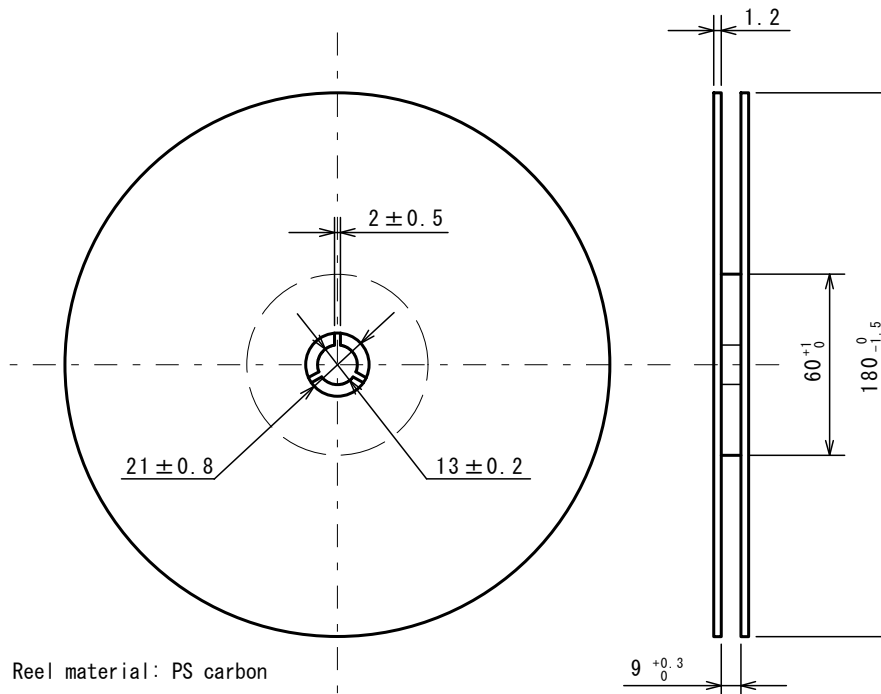

(4) Peeling strength

Peeling strength of cover tape

- Peeling angle 165 to 180° degrees to the taped surface.
- Peeling speed 300mm/min
- Peeling strength 0.1 to 1.0N

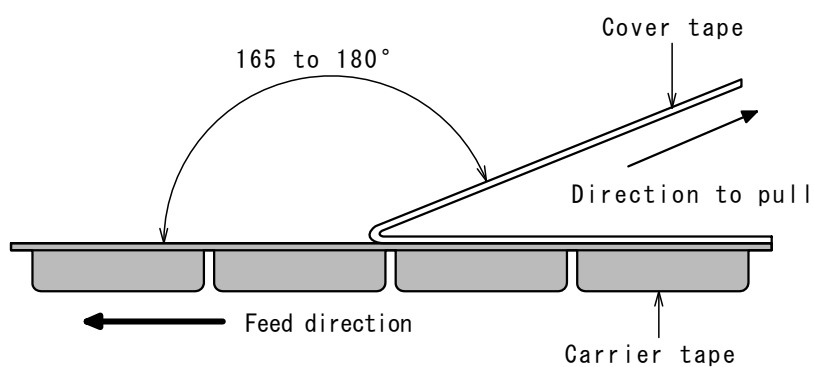

Nisshinbo Micro Devices Inc.

DFN6-GC(ESON6-GC)

PI-DFN6-GC-E-B

(5) Packing state

<Label> Product name, Quantity, Lot No., Mark

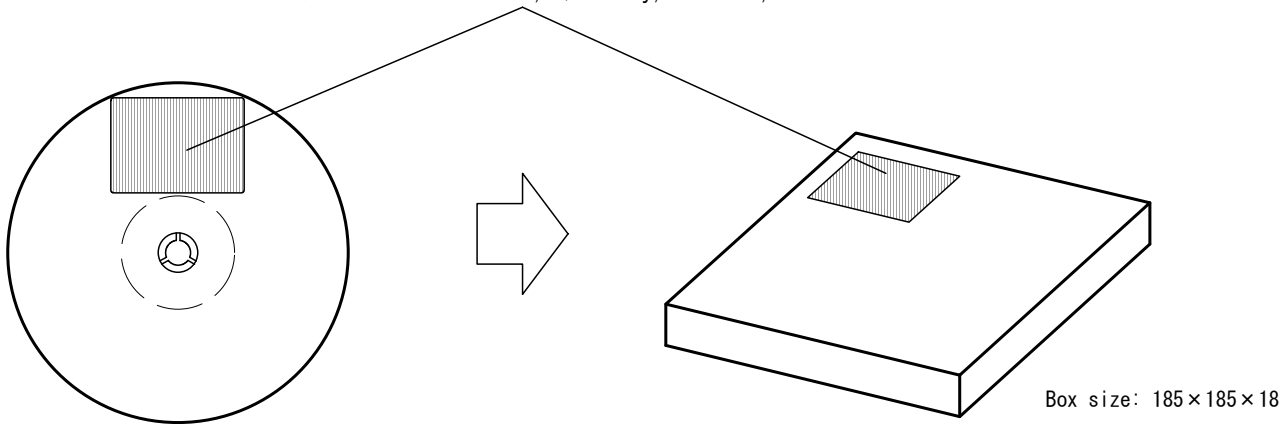

■ HEAT-RESISTANCE PROFILES

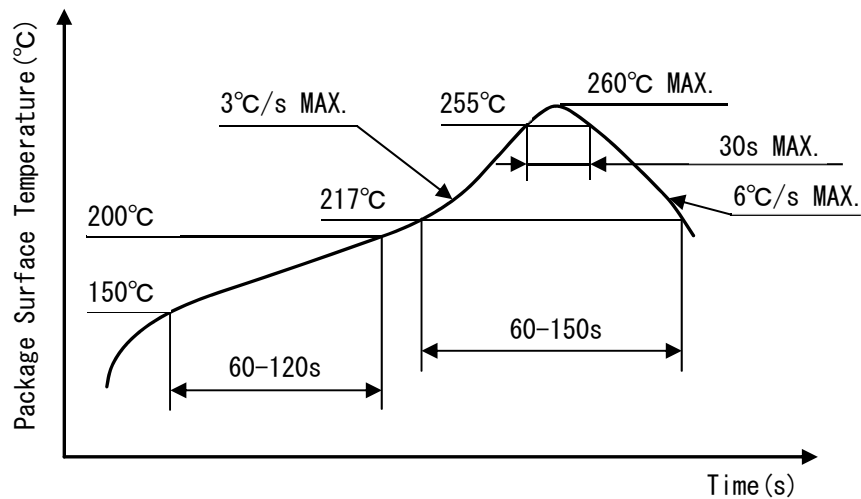

Reflow profile

1. The products and the product specifications described in this document are subject to change or discontinuation of production without notice for reasons such as improvement. Therefore, before deciding to use the products, please refer to our sales representatives for the latest information thereon.
2. The materials in this document may not be copied or otherwise reproduced in whole or in part without the prior written consent of us.
3. This product and any technical information relating thereto are subject to complementary export controls (so-called KNOW controls) under the Foreign Exchange and Foreign Trade Law, and related politics ministerial ordinance of the law. (Note that the complementary export controls are inapplicable to any application-specific products, except rockets and pilotless aircraft, that are insusceptible to design or program changes.) Accordingly, when exporting or carrying abroad this product, follow the Foreign Exchange and Foreign Trade Control Law and its related regulations with respect to the complementary export controls.
4. The technical information described in this document shows typical characteristics and example application circuits for the products. The release of such information is not to be construed as a warranty of or a grant of license under our or any third party's intellectual property rights or any other rights.
5. The products listed in this document are intended and designed for automotive applications. Those customers intending to use a product in an application requiring extreme quality and reliability, for example, in a highly specific application where the failure or misoperation of the product could result in human injury or death should first contact us.
 - Aerospace Equipment
 - Equipment Used in the Deep Sea
 - Power Generator Control Equipment (nuclear, steam, hydraulic, etc.)
 - Life Maintenance Medical Equipment
 - Fire Alarms / Intruder Detectors
 - Vehicle Control Equipment (airplane, railroad, ship, etc.)
 - Various Safety Devices
 - Traffic control system
 - Combustion equipment

In case your company desires to use this product for any applications other than general electronic equipment mentioned above, make sure to contact our company in advance. Note that the important requirements mentioned in this section are not applicable to cases where operation requirements such as application conditions are confirmed by our company in writing after consultation with your company.

6. We are making our continuous effort to improve the quality and reliability of our products, but semiconductor products are likely to fail with certain probability. In order to prevent any injury to persons or damages to property resulting from such failure, customers should be careful enough to incorporate safety measures in their design, such as redundancy feature, fire containment feature and fail-safe feature. We do not assume any liability or responsibility for any loss or damage arising from misuse or inappropriate use of the products.
7. The products have been designed and tested to function within controlled environmental conditions. Do not use products under conditions that deviate from methods or applications specified in this datasheet. Failure to employ the products in the proper applications can lead to deterioration, destruction or failure of the products. We shall not be responsible for any bodily injury, fires or accident, property damage or any consequential damages resulting from misuse or misapplication of the products.
8. **Quality Warranty**
 - 8-1. **Quality Warranty Period**
In the case of a product purchased through an authorized distributor or directly from us, the warranty period for this product shall be one (1) year after delivery to your company. For defective products that occurred during this period, we will take the quality warranty measures described in section 8-2. However, if there is an agreement on the warranty period in the basic transaction agreement, quality assurance agreement, delivery specifications, etc., it shall be followed.
 - 8-2. **Quality Warranty Remedies**
When it has been proved defective due to manufacturing factors as a result of defect analysis by us, we will either deliver a substitute for the defective product or refund the purchase price of the defective product.
Note that such delivery or refund is sole and exclusive remedies to your company for the defective product.
 - 8-3. **Remedies after Quality Warranty Period**
With respect to any defect of this product found after the quality warranty period, the defect will be analyzed by us. On the basis of the defect analysis results, the scope and amounts of damage shall be determined by mutual agreement of both parties. Then we will deal with upper limit in Section 8-2. This provision is not intended to limit any legal rights of your company.
9. Anti-radiation design is not implemented in the products described in this document.
10. The X-ray exposure can influence functions and characteristics of the products. Confirm the product functions and characteristics in the evaluation stage.
11. WLCSP products should be used in light shielded environments. The light exposure can influence functions and characteristics of the products under operation or storage.
12. Warning for handling Gallium and Arsenic (GaAs) products (Applying to GaAs MMIC, Photo Reflector). These products use Gallium (Ga) and Arsenic (As) which are specified as poisonous chemicals by law. For the prevention of a hazard, do not burn, destroy, or process chemically to make them as gas or power. When the product is disposed of, please follow the related regulation and do not mix this with general industrial waste or household waste.
13. Please contact our sales representatives should you have any questions or comments concerning the products or the technical information.



Nisshinbo Micro Devices Inc.

Official website

<https://www.nisshinbo-microdevices.co.jp/en/>

Purchase information

<https://www.nisshinbo-microdevices.co.jp/en/buy/>