



40ACB1E_4 series

40W - AC-DC converter

AC-DC Converter

40 Watt

- ⊕ Wide input voltage range 85-265VAC/120-380VDC
- ⊕ No load power consumption $\leq 0.3W$
- ⊕ Transfer efficiency 86% (typ.)
- ⊕ Switching frequency 65kHz
- ⊕ Isolation voltage 4000VAC
- ⊕ Protections: short circuit, over current
- ⊕ Meets IEC62368/UL62368/EN62368 test standards
- ⊕ RoHS compliant

Introducing our versatile and efficient 40ACB1E_4 series, featuring a wide input voltage range of 85-265VAC/120-380VDC. With no load power consumption of $\leq 0.3W$ and a typical transfer efficiency of 86%, it ensures optimal energy utilization. Operating at a switching frequency of 65KHz, it provides reliable performance. The power supply boasts an isolation voltage of 4000VAC and includes protections for short circuit and over current scenarios. It meets IEC62368/UL62368/EN62368 test standards and is certified with RoHS, ensuring compliance and safety.



Common specifications	
Short circuit protection	Full input voltage range - Continuous, Self-recovery Hiccup
Over current protection	Input 220VAC - $\geq 130\%$ Io self-recovery - Hiccup
Switching frequency	65 kHz (typ.)
Operating temperature	-40°C - +75°C
Storage temperature	-40°C - +85°C
Soldering temperature	Wave soldering 260°C ($\pm 4^\circ\text{C}$), time 5-10S Manual soldering 360°C ($\pm 8^\circ\text{C}$), time 4-7S
Relative humidity	10-90% RH
Hot plug	Unavailable
Remote control terminal	Unavailable
Safety standard	EN62368, IEC62368
Vibration	10-55Hz, 10G, 30Min, along X, Y, Z
Safety class	CLASS II
MTBF (MIL-HDBK-217F@25°C)	>300,000 Hours
Cooling method	Free air convection

Output specifications					
Item	Operating condition	Min	Typ	Max	Units
Voltage accuracy	Full input voltage range, any load		± 2.0	± 4.0	%
Line Regulation	Nominal Load			± 0.5	%
Load regulation	Nominal input voltage, 20%-100% load			± 3.0	%
No load power consumption	Input 115VAC Input 220VAC			0.3	W
Minimum load	Single Output	0			%
Start-up delay time	Nominal input voltage (full load)		1000		mS
Power-off holding time	Input 115VAC (full load) Input 220VAC (full load)		200 100		mS
Dynamic response	Overshoot range 25%-50%~25% Recovery time 50%-75%~50%	-5.0		+5.0 5.0	% mS
Output overshoot	Full input voltage range		$\leq 10\%V_o$		%
Drift coefficient		-	$\pm 0.03\%$	-	%/°C
Ripple noise*			50	100	mV

Note: *Ripple & Noise is tested by twisted pair method, details please see ripple & noise test at back.

Input specifications					
Item	Operating condition	Min	Typ	Max	Units
Input voltage range	AC input	85	220	265	VAC
	DC input	120	310	380	VDC
Input frequency range		47	50	63	Hz
Input current	115VAC			0.8	A
	220VAC			0.5	A
Surge current	115VAC			10	A
	220VAC			20	A
External fuse	3.15A/250VAC, slow-fusing				
Leakage current	0.5mA typ/230VAC/50Hz				

Isolation specifications					
Item	Operating Conditions	Min	Typ	Max	Units
Isolation voltage	Input-Output, test 1min, leakage current $\leq 5\text{mA}$	4000			VAC
Insulation resistance	Input-Output@DC500V	100			MΩ

1. The product should be used under the specification range, otherwise it will cause permanent damage to it.
2. Product's input terminal should connect to fuse;
3. If the product operated below the minimum load request, we cannot ensure that the performance of product is in accordance with all the indexes in this manual;
4. If the product worked beyond the load range, we cannot ensure that the performance of product is in accordance with all the indexes in this manual;
5. Unless otherwise specified, data in this datasheet are tested under conditions of $T_a = 25^\circ\text{C}$, humidity <75% when inputting nominal voltage and outputting rated load (pure resistance load);
6. All index testing methods in this datasheet are based on our company's corporate standards.
7. The performance indexes of the product models listed in this manual are as above, but some indexes of non-standard model products will exceed the above-mentioned requirements, please directly contact our technician for specific information;
8. The product specification may be changed at any time without prior notice.

Example:
40ACB1E_05S4
 40 = 40Watt; AC = AC-DC; B1 = Series; E = Cost effective;
 05 = 5Vout; S = Single output; 4 = 4 kVAC isolation

40ACB1E_4 series

40W - AC-DC converter

EMC specifications					
EMC	EMI	CE	CISPR22/EN55032	CLASS B (see recommended circuit Photo 2)	
EMC	EMI	RE	CISPR22/EN55032	CLASS B (see recommended circuit Photo 2)	
EMC	EMS	RS	IEC/EN61000-4-3	10V/m	Perf.Criteria B (see recommended circuit Photo 1)
EMC	EMS	CS	IEC/EN61000-4-6	3Vr.m.s	Perf.Criteria B (see recommended circuit Photo 1)
EMC	EMS	ESD	IEC/EN61000-4-2	Contact ±6KV / Air ±8KV	Perf.Criteria B
EMC	EMS	Surge	IEC/EN61000-4-5	±1KV	Perf.Criteria B
EMC	EMS	EFT	IEC/EN61000-4-4	±2KV	Perf.Criteria B
EMC	EMS	Voltage dips and interruptions	IEC/EN61000-4-11	0%~70%	Perf.Criteria B

Product Selection Guide

Approval	Model	Output Power (W)	Output Voltage Vo1(V)	Output Current Io1(mA)	Max. Capacitive Load (uF)	Ripple & Noise 20MHz (Max) mVp-p	Efficiency Full Load, 220VAC Typ. (%)
	40ACB1E_05S4	40	5	8000	5000	100	79
	40ACB1E_12S4	40	12	3333	1000	120	84
	40ACB1E_24S4	40	24	1667	1000	150	86

Note:

1. The typical value of output efficiency is based on product is full loaded and burned-in after half an hour.
2. Fluctuation range of full load efficiency (%typ) is ±2%. Full load efficiency=Total output power / module's Input power.
3. Ripple & noise is tested by twisted pair method, details please see ripple & noise test at back.

Product characteristic curve

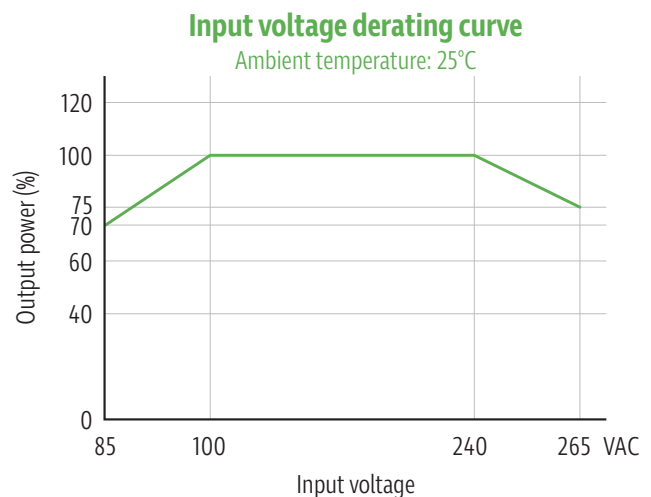
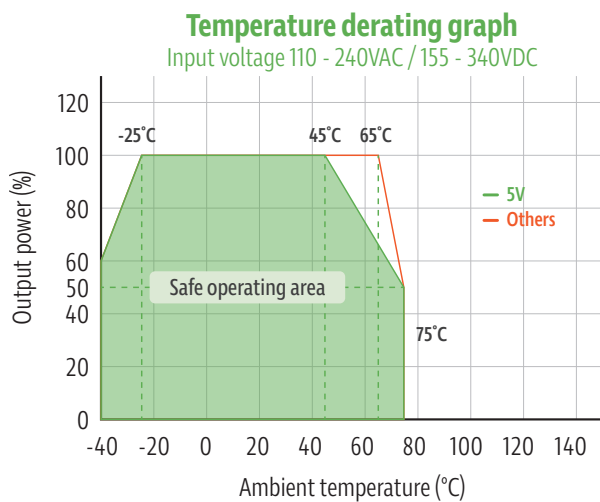

- Note
- 1: Input Voltage should be derated base on Input Voltage Derating Curve when it is 85~110VAC/240~265VAC/120~155VDC/ 340~380VDC. Derating of FA40-220S05W2D4 based on 5V curve.
 - 2: Our product is suitable to use under natural air cooling environment.

40ACB1E_4 series

40W - AC-DC converter

Mechanical dimensions

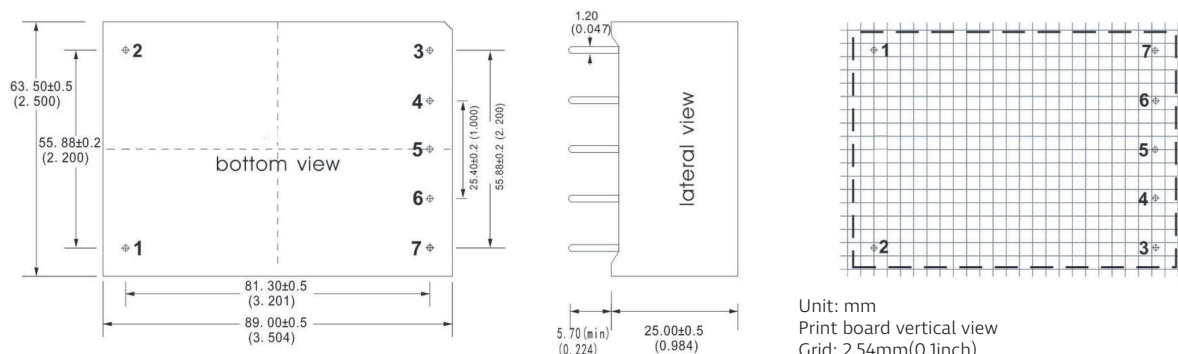

Unit: mm
 Print board vertical view
 Grid: 2.54mm(0.1inch)
 General tolerance: ±0.25mm
 Pin section tolerances: ±0.10mm

Pin	1	2	3	4	5	6	7
Single	AC (L)	AC (N)	Trim	NC	-Vo	NC	+Vo

Trim pin voltage regulation application circuit

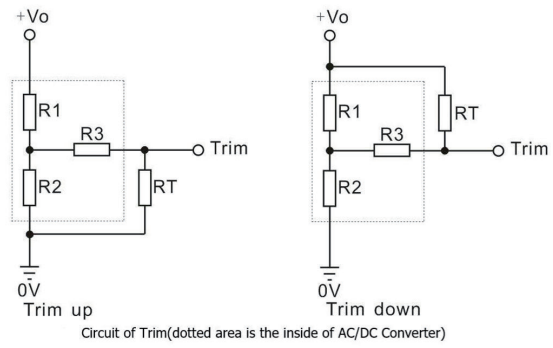

$$\text{up: } RT = \frac{aR2}{R2-a} - R3 \quad a = \frac{V_{ref}}{V_o - V_{ref}} * R1$$

$$\text{down: } RT = \frac{aR1}{R1-a} - R3 \quad a = \frac{V_{ref}}{V_o - V_{ref}} * R2$$

AC-DC Converter	R1 (KΩ)	R2 (KΩ)	R3 (KΩ)	Vref (V)	+Vo(V)
40ACB1E_05S4	5.1	5.07	1	2.5	Adjusted output voltage amplitude ±10%
40ACB1E_12S4	39	10.2	1	2.5	Adjusted output voltage amplitude ±10%
40ACB1E_24S4	39	4.52	1	2.5	Adjusted output voltage amplitude ±10%

Typical EMC application and recommend circuit

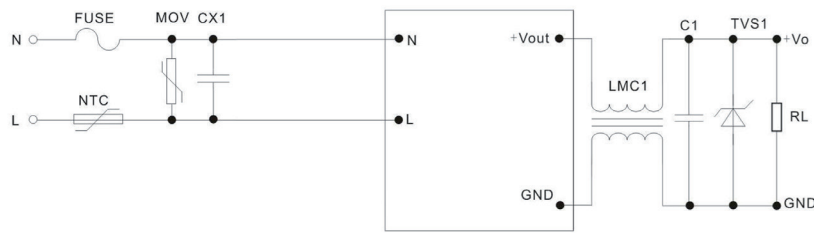

Photo 1

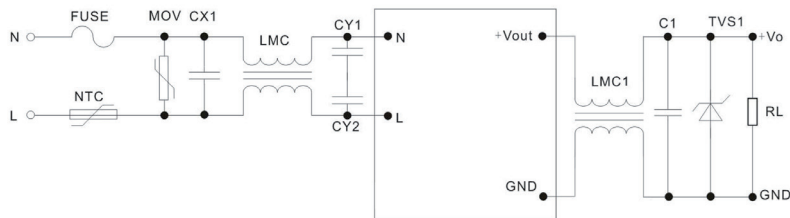

Photo 2

Note:

1. Output filter capacitors C1 filters high frequency noise, recommend to use 1 μ F ceramic capacitor, capacitance withstand voltage derating should be 80% or above.
2. TVS is a recommended component to protect post-circuits if converter fails, recommend to use 600W model. 5V output recommend: SMBJ7.0A, 9V output recommend: SMBJ12.0A, 12V output recommend: SMBJ20A, 15V output recommend: SMBJ20.0A, 24V output recommend: SMBJ30.0A, 48V output recommend: SMBJ64A.
3. MOV is voltage depend resistor, recommend model: 10D561K, to protect converter from damage when lightning surge
4. For customer's normal application request, use Photo 1 recommended circuit, if has higher EMC request, use Photo 2 recommended circuit. The spec for Photo 2 as below:
 - 1) MOV: voltage dependent resistor, recommend model: 10D-561K, to protect converter from damage when lightning surge.
 - 2) NTC: Thermistors, 10D-9;
 - 3) CY1, CY2: safety capacitor, 1000pF/400VAC;
 - 4) CX: safety capacitor, 0.1 μ F/275VAC;
 - 5) LCM: common mode inductor, 15mH-30mH;
 - 6) LCM1: common mode inductor, 30uH-50uH;
 - 7) FUSE: necessary, recommend model 3.15A/250V, slow fusing.