



## 10ACEW\_4 series

10Watt - AC-DC converter

# AC-DC Converter 10 Watt

- ⊕ Ultra-wide 85-305VAC and 100-430VDC input voltage range
- ⊕ Operating ambient temperature range: -40°C to +85°C
- ⊕ Up to 85% efficiency
- ⊕ No-load power consumption 0.1W
- ⊕ 5000m altitude application
- ⊕ EMI performance meets CISPR32/EN55032 CLASS B, EN55014
- ⊕ IEC/EN/UL62368/EN60335/EN61558 safety approved
- ⊕ Over-voltage Class III (meets EN61558-1)



10ACEW\_4 series AC-DC converters is one of GAPTEC's new generation compact size power converter. It features ultra-wide AC input and at the same time accepts DC input voltage, low power consumption, low ripple & noise, high efficiency, high reliability, reinforced isolation. It offers good EMC performance compliant to IEC/EN61000-4 and CISPR32/EN55032 and meets IEC/EN/UL62368/EN60335/EN61558 standards. The converters are widely used in industrial, power, home appliances, instrumentation, communication and civil applications. For extremely harsh EMC environment, we recommend using the application circuit show in Design Reference of this datasheet.

Common specifications					
Item	Operating condition	Min	Typ	Max	Units
Short circuit protection:		Hiccup, continuous, self-recovery			
Cooling:		Free air convection			
Operating temperature:		-40		+85	°C
Storage Temperature		-40		+85	°C
Soldering Temperature:	Wave-soldering Manual-welding	260 ± 5°C; time: 5 - 10s 360 ± 10°C; time: 3 - 5s			
Storage humidity:				95	%RH
Switching Frequency			65		kHz
Power derating:	-40°C to -25°C 85VAC - 115VAC	2.2			%/°C
	+50°C to +70°C: 3.3V/5V	2.5			%/°C
	+55°C to +70°C: 9V/12V/15/24V	3.33			%/°C
	+70°C to +85°C:	0.66			%/°C
	85VAC - 100VAC:	0.83			%/°VAC
2000m - 5000m:		0.67			%/Km
Safety standard:	IEC/UL62368-1, EN61558-1, EN60335-1 Safety Approval & EN62368-1 (Report)				
Safety Class:		Class II			
MTBF: (MIL-HDBK-217F@25°C)		> 3200,000 h			
Hot plug:	Unavailable				
Case material:	Black plastic, flame-retardant and heat-resistant (UL94V-0)				
Designed Life: (230VAC)	Ta: 25°C 100% load	>130x10 <sup>3</sup> h			
	Ta: 55°C 100% load	>20x10 <sup>3</sup> h			
	Ta: 55°C 80% load	>27x10 <sup>3</sup> h			
Dimension	• DIP package	40.00 x 25.40 x 21.00 mm			
	• Chassis mounting	76.00 x 31.50 x 29.80 mm			
	• DIN rail mounting	76.00 x 31.50 x 34.40 mm			
Weight:	• DIP mounting	34			g
	• Chassis mounting	54			g
	• DIN rail mounting	74			g

Input specifications					
Item	Operating condition	Min	Typ	Max	Units
Input voltage range	• AC Input	85		305	VAC
	• DC Input	100		430	VDC
Input frequency		47		63	Hz
Input current	• 115VAC			0.23	A
	• 230VAC			0.15	A
Inrush current	• 115VAC		25		A
	• 230VAC		40		A
Leakage Current	277VAC/50Hz	0.1mA RMS Max.			
Fuse(A2S/A4S package series include fuse)	2A/300V, slow-blow, required				
Hot Plug	Unavailable				

Output specifications					
Item	Operating condition	Min	Typ	Max	Units
Voltage accuracy			±2		%
Line regulation	Full load		±0.5		%
Load regulation	0% - 100% load		±1		%
Ripple & Noise*	20MHz bandwidth (peak-to-peak value)		50	100	mV
		Stand-by Power Consumption	230VAC • 3.3/5/9/12/15V • 24V	0.10 0.12	
Temperature Coefficient			±0.02		%/°C
Over-current Protection	≥110%Io, self-recovery				
Over-voltage Protection**	3.3/5VDC output			≤7.5VDC	
	9VDC output			≤15VDC	
	12/15VDC output			≤20VDC	
	24VDC output			≤30VDC	
Min. load		0			%
Hold-up Time	115VAC input		8		ms
	230VAC input		40		ms

\* The "Tip and barrel method" is used for ripple and noise test, output parallel 10uF electrolytic capacitor and 1uF ceramic capacitor, please refer to AC-DC Converter Application Notes for specific information.  
 \*\* Output voltage clamp or hiccup.

Isolation specifications					
Item	Operating Conditions	Min	Typ	Max	Units
Isolation (Input-Output)	Electric Strength Test for 1min, leakage current <5mA	4000			VAC
Insulation Resistance (Input-output)	At 500VDC	100			MΩ

**Example:**  
**10ACEW\_03S4**  
 10 = 5Watt; AC = AC-DC; E = case style ; W = wide input  
 03 = 3.3Vout; S = Single output; 4 = 4kVAC isolation

- Note:**
- If the product is not operated within the required load range, the product performance cannot be guaranteed to comply with all parameters in the datasheet;
  - Unless otherwise specified, parameters in this datasheet were measured under the conditions of Ta = 25°C, humidity <75% with nominal input voltage and rated output load;
  - All index testing methods in this datasheet are based on our company corporate standards;
  - We can provide product customization service, please contact our technicians directly for specific information;
  - Products are related to laws and regulations: see "Features" and "EMC";
  - Our products shall be classified according to ISO14001 and related environmental laws and regulations, and shall be handled by qualified units.

# 10ACEW\_4 series

10Watt - AC-DC converter

EMC specifications				
Emissions	CE	CISPR32/EN55032 CLASS B EN55014-1		
Emissions	RE	CISPR32/EN55032 CLASS B EN55014-1		
Immunity	ESD	IEC/EN 61000-4-2 EN55014-2	Contact ±8KV/Air ±15KV	perf. Criteria B perf. Criteria B
Immunity	RS	IEC/EN 61000-4-3 EN55014-2	10V/m	perf. Criteria A perf. Criteria A
Immunity	EFT	IEC/EN61000-4-4 ±2KV IEC/EN61000-4-4 ±4KV (See Fig.2 for recommended circuit) EN55014-2		perf. Criteria B perf. Criteria B perf. Criteria B
Immunity	Surge	IEC/EN61000-4-5 line to line ±1KV (See Fig.1 for typical application circuit) IEC/EN61000-4-5 line to line ±2KV (See Fig.2 for recommended circuit) EN55014-2		perf. Criteria B perf. Criteria B perf. Criteria B
Immunity	CS	IEC/EN 61000-4-6 EN55014-2	10 Vr.m.s	perf. Criteria A perf. Criteria A
Immunity	Voltage dip, short interruption and voltage variation	IEC/EN 61000-4-11 EN55014-2	0%-70%	perf. Criteria B perf. Criteria B

## Product Selection Guide

Approval	Model	Power [W]	Output [Vo]	Output [Io]	Efficiency [% , typ]	Capacitive load [µF, max]
UL	10ACEW_03S4	8.6	3.3V	2600mA	74	6600
UL	10ACEW_05S4	10	5V	2000mA	79	5000
UL	10ACEW_09S4	10	9V	1100mA	81	3600
UL	10ACEW_12S4	10	12V	830mA	84	2000
UL	10ACEW_15S4	10	15V	660mA	84	820
UL	10ACEW_24S4	10	24V	410mA	85	470

Note: \* Use suffix "/CM" for chassis and suffix "/DR" for DIN-Rail mounting.

## Product Characteristic Curve

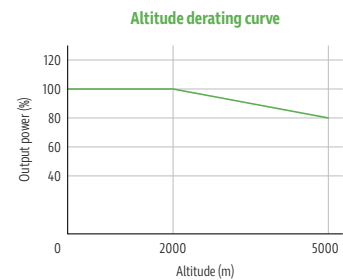
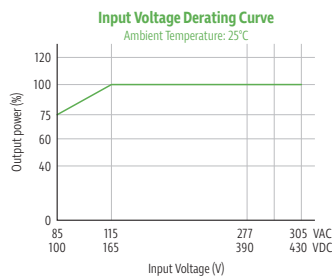
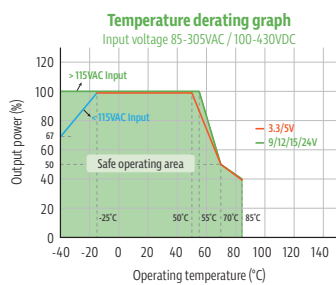

Note:

- With an AC input between 85-115VAC and a DC input between 100-165VDC, the output power must be derated as per temperature derating curves;
- This product is suitable for applications using natural air cooling; for applications in closed environment.

## Efficiency

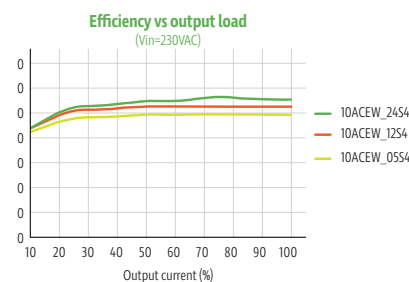
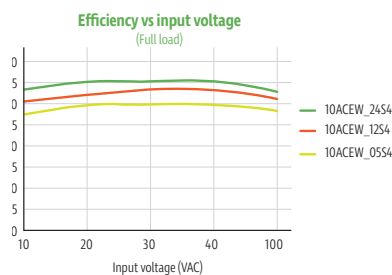

## Typical application

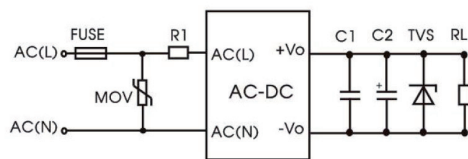

Fig. 1: Typical circuit diagram

Part No.	FUSE	MOV	R1	C1 (μF)	C2 (μF)	TVS
10ACEW_03S4	2A/300V, slow-blow, required	S14K350	6.8Ω/3W (wire-wound resistor, required)	1μF/50V	220μF/16V	SMBJ7.0A
10ACEW_05S4					220μF/16V	SMBJ7.0A
10ACEW_09S4					100μF/25V	SMBJ12A
10ACEW_12S4					100μF/25V	SMBJ20A
10ACEW_15S4					100μF/25V	SMBJ20A
10ACEW_24S4					100μF/35V	SMBJ30A

### Output Filter Components:

We recommend using an electrolytic capacitor with high frequency, and low ESR rating for C2 (refer to manufacture's datasheet). Choose a Capacitor voltage rating with at least 20% margin, in other words not exceeding 80%. C1 is a ceramic capacitor used for filtering high-frequency noise and TVS is a recommended suppressor diode to protect the application in case of a converter failure.

## EMC compliance recommended circuit

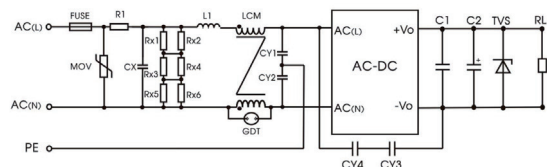

Component	Recommended value
FUSE	2A/300V,slow-blow,required
MOV	S14K350
CX	334K/305VAC
R1	12Ω/5W (wire-wound resistor, required)
L1	1.2mH/0.5A
CY1/CY2	2.2nF/400VAC
CY3/CY4	1nF/400VAC
GDT	300V/1KA
LCM	20 mH

## Dimensions and Recommended Layout

THIRD ANGLE PROJECTION

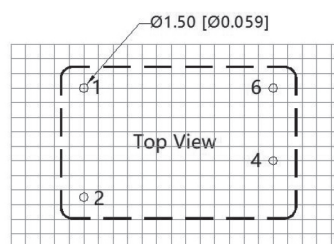
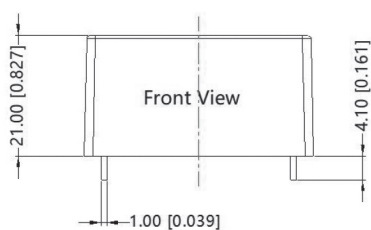

Note: Grid 2.54\*2.54mm

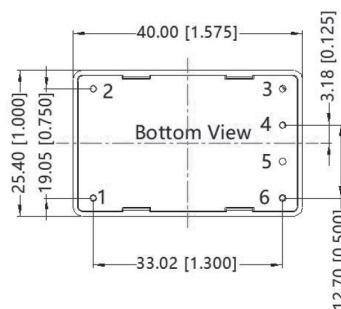

Note:

Unit: mm[inch]

Pin diameter tolerances: ±0.10[±0.004]

General tolerances: ±0.50[±0.020]

Pin-Out	
Pin	Function
1	AC(L)
2	AC(N)
3	No Pin
4	+Vo
5	No Pin
6	-Vo

# 10ACEW\_4 series

10Watt - AC-DC converter

## Chassis mounting

THIRD ANGLE PROJECTION 

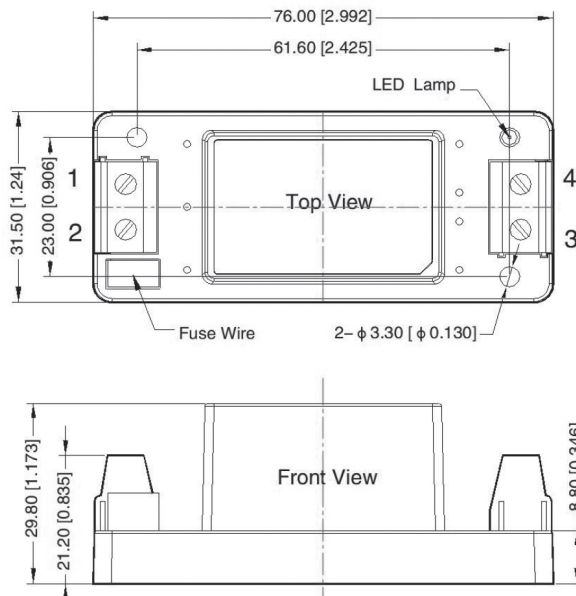

Pin-Out	
Pin	Function
1	AC(N)
2	AC(L)
3	-Vo
4	+Vo

Note:  
 Unit: mm[inch]  
 Wire range: 24-12 AWG  
 Tightening torque: Max 0.4 N-m  
 General tolerances: ± 1.00 [± 0.039]

## DIN rail mounting

THIRD ANGLE PROJECTION 

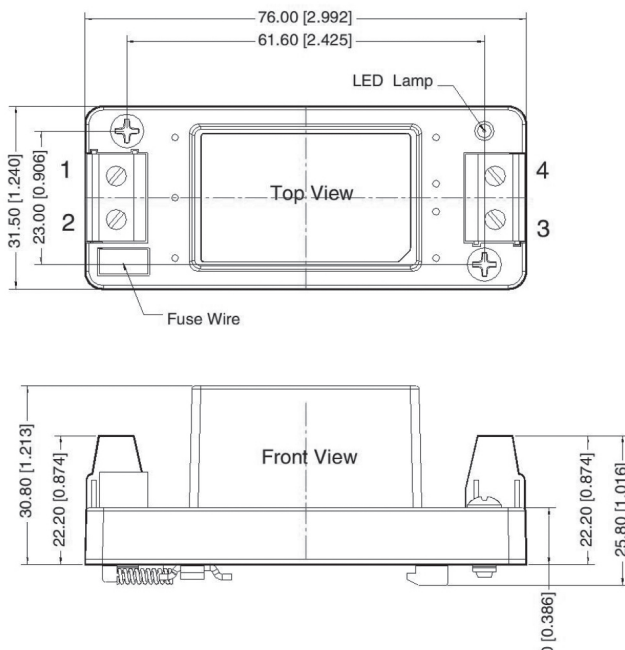

Pin-Out	
Pin	Function
1	AC(N)
2	AC(L)
3	-Vo
4	+Vo

Note:  
 Unit: mm[inch]  
 Wire range: 24-12 AWG  
 Tightening torque: Max 0.4 N-m  
 Mounting rail: TS35, rail needs to connect safety ground  
 General tolerances: ± 1.00 [± 0.039]