



Technical Data Sheet

Omega ANSI Current Transformer Series



Omega 30
19SHT
19RL

Omega 30 - 19SHT



Approx weight 1.75lbs

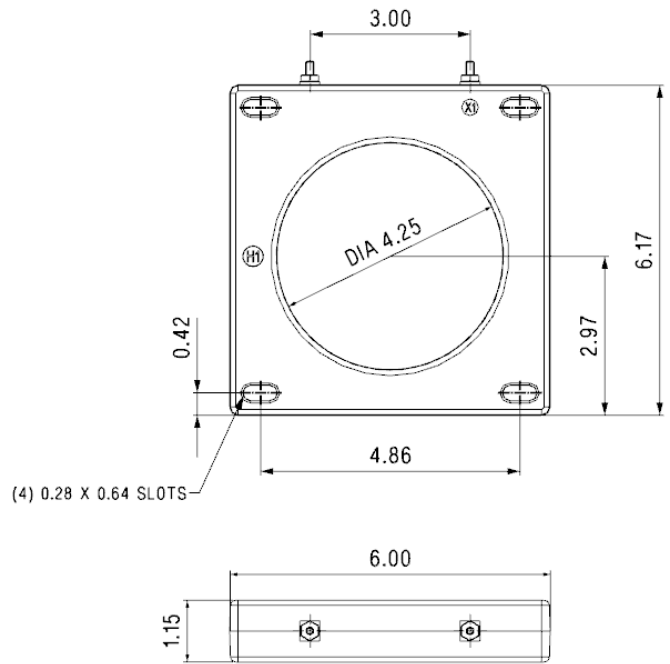

All the mentioned dimensions are in inches

Omega 30 - 19RL
(Pass through conductor mounting type)



Approx weight 1.75lbs

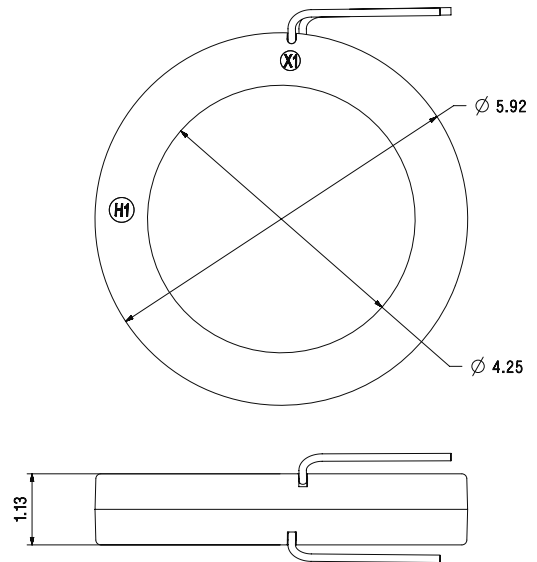

All the mentioned dimensions are in inches

Omega 30 - 19SHT, 19RL

Catalogue Number	CURRENT RATIO	RATED BURDEN FOR ACC. C.L.± 1%	ANSI METERING CLASS AT 60 HZ (% Accuracy at specified Burden Impedance in Ohms)					SECONDARY WINDING RESISTANCE (OHMS @ 75° C)	CONTINUOUS RATING FACTOR (UL Testing Done @RF 1)	
			B0.1	B0.2	B0.5	B0.9	B1.8		@ 30°C	@ 55°C
19**-301	300:5	4	0.6	1.2	2.4	-	-	0.070	2	2
19**-401	400:5	10	0.3	0.6	1.2	-	-	0.094	2	2
19**-501	500:5	15	0.3	0.6	1.2	-	-	0.122	2	1.5
19**-601	600:5	15	0.3	0.3	0.6	1.2	-	0.155	2	1.5
19**-701	700:5	25	0.3	0.3	0.6	0.6	-	0.182	1.5	1.33
19**-801	800:5	30	0.3	0.3	0.6	0.6	-	0.266	1.5	1.33
19**-102	1000:5	30	0.3	0.3	0.6	0.6	-	0.358	1.33	1
19**-122	1200:5	40	0.3	0.3	0.3	0.6	-	0.419	1.33	1
19**-152	1500:5	15	0.3	0.3	0.6	1.2	-	0.406	1.5	1
19**-162	1600:5	15	0.3	0.3	0.3	0.6	-	0.434	1.5	1
19**-202	2000:5	20	0.3	0.3	0.3	0.6	-	0.532	1.33	1
19**-252	2500:5	20	0.3	0.3	0.3	0.3	-	0.700	1	0.8
19**-302	3000:5	25	0.3	0.3	0.3	0.3	-	0.840	1	0.8
19**-402	4000:5	25	0.3	0.3	0.3	0.3	-	0.600	1	0.8

Specifications

- Applicable Standard : ANSI/IEEE C57.13
- Case : 10% glass filled polycarbonate, flame retardant grades classified UL 94V-0.
- Frequency : 50-400 Hz.(UL testing done at 50/60Hz)
- Insulation Level : (System Voltage 600V)10KV BIL full wave.
- Flexible leads are UL 1015, 105°C, CSA approved, #16AWG, 24"long without lugs (For RL type). Non-standard length to be specified for RL type if required.
- For all the SHT types terminal are brass stud size 8-32 with one M4 type flat washer, lock washer & hex nut size 8-32UNC.
- All the SHT models also available as SHL with leads (UL approval not applicable for SHL type).
- For SHT type- mounting bracket kit can be provided on request order code SPAR-SA00-2337.
- Ambient temperature: -30°C to +55°C (RH upto 95% non-condensing).
- Storage temperature : -50°C...+80°C.

Application

- Use for measurement purposes in conjunction with ammeters, wattmeters, etc.
- Can be used for cross current compensation applications.

Wiring Diagram

- H1-H2 : Direction of input power supply
- X1-X2 : Direction of output power
- Use 16 AWG wire with M4 ring-type lug for models SHT.
- Secondary connection 8-32 UNC hex nut. Terminal torque 13 lb·in [1.5Nm].

It is forbidden to operate the current transformer without a secondary connected to burden/load or short circuited.

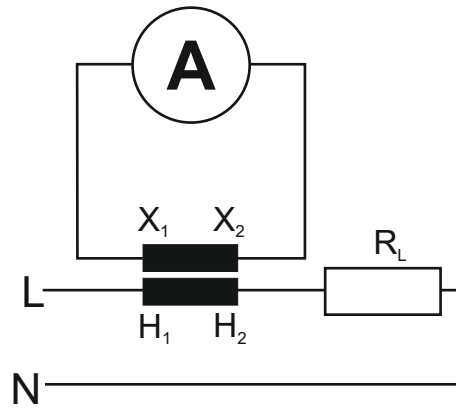

Fig. Wiring diagram

Notes :

Not for use with variable frequency drives.

RF = the maximum current at which a CT can operate continuously without exceeding the thermal limits of its insulation.

Sifam Tinsley Instrumentation Inc.

Address: 2105 Barrett Park Drive Unit 105, Kennesaw, GA 30144

Tel.: 800-879-6171 | **E-mail:** info@sifamtinsley.com | **Web:** www.sifamtinsley.com