

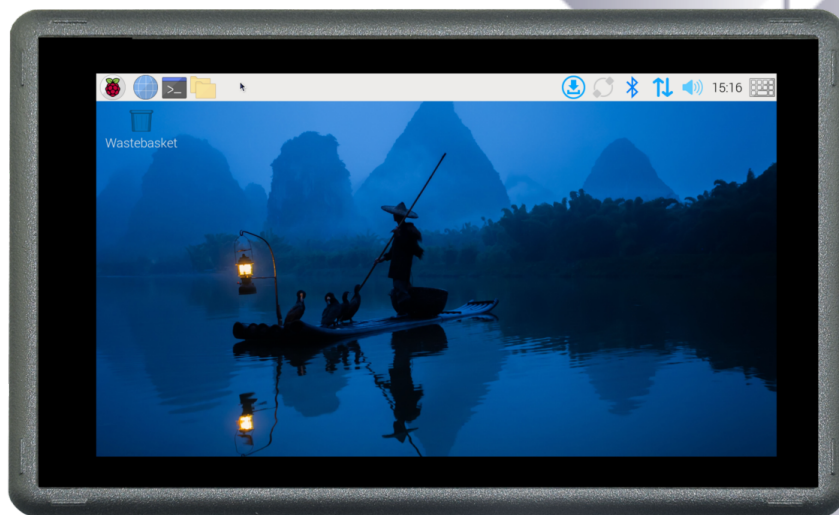

Industrial PC

PPC-CM5-050



PN: CS12720RA5050

Content can change at anytime, check our website for latest information of this product.

www.chipsee.com

Contents

PPC-CM5-050	3
1. Product Overview	7
2. Ordering Options	8
2.1. Pi [®] CM5 Module	8
2.2. Operating System	8
3. Specifications	9
4. Power Input	11
5. Touch Screen	12
6. Connectivity	13
6.1. RS232/RS485/CAN	13
6.2. USB Connectors	15
6.3. LAN	17
6.4. WiFi & BT Module	18
6.5. Camera Connector	19
7. TF Card Slot	21
8. Audio Connectors	22
9. HDMI Connector	23
10. PROG Button	24
11. Mounting Procedure	25
11.1. CS12720RA5050	25
12. Mechanical Specifications	26
12.1. CS12720RA5050	26
13. 3D Model	27
14. Disclaimer	28
15. Technical Support	28

PPC-CM5-050

Front View

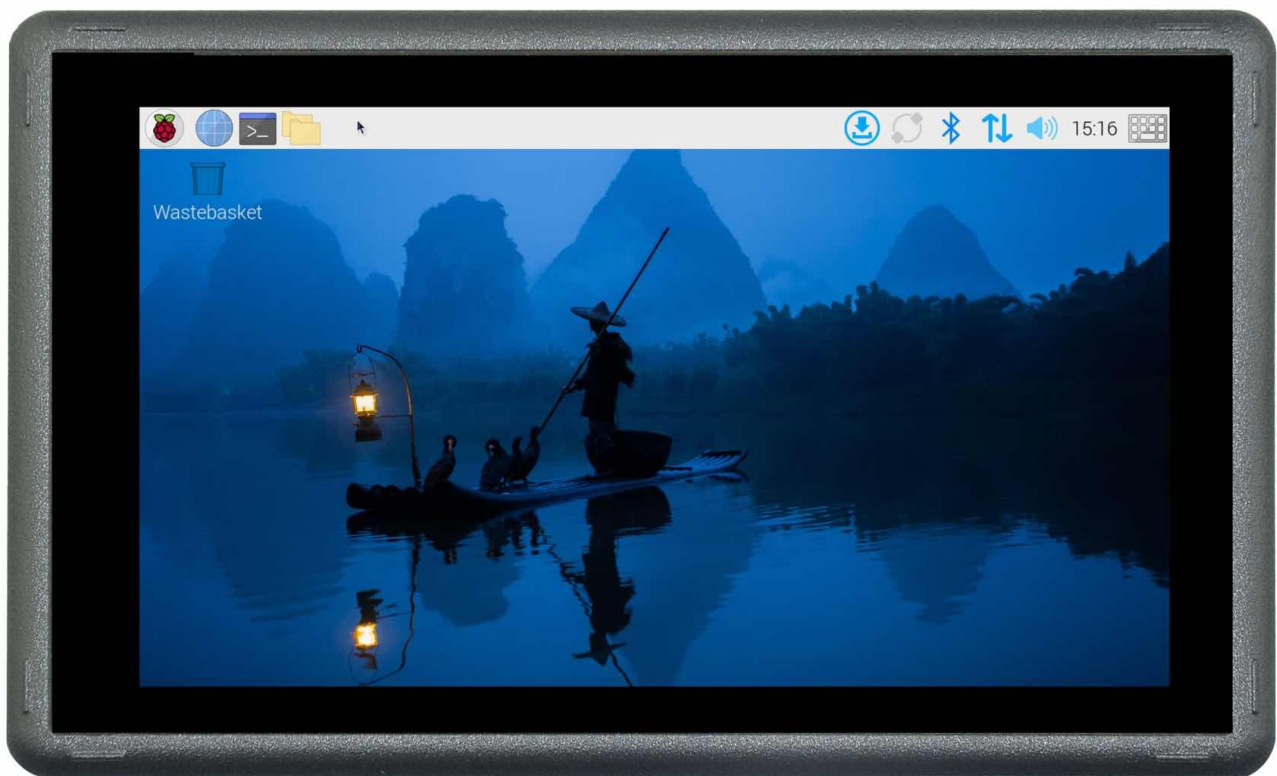

Rear View



Side View 1



Side View 2



Product Overview

The Cortex[®]-A76 Raspberry Pi[®] series PPC-CM5-050 (PN: CS12720RA5050) is a high-quality industrial Pi PC. It features a 5" five-point capacitive touch screen with a resolution of 1280 x 720 pixels and brightness of 400 cd/m².

Key Applications

- Human Machine Interface HMI
- Process Control
- Process Monitoring
- HMI
- IIoT node
- Environmental Monitoring
- PLC
- Automotive applications
- ATM...

It is available as a device housed in a casing with bezels, thus facilitating different installation options:

- Installation on an industrial cabinet
- Integration with the existing equipment

The PPC-CM5-050 industrial Pi PC is based around the powerful Raspberry Pi[®] Compute Module 5, powered by the Quad Cortex[®]-A76 processor with a processor speed of 2.4GHz.

Ordering Options

Chipsee products can be customized during the ordering process. The product will be shipped with the pre-installed factory defaults if no extra requirements are specified. The table in the [Specifications](#) section provides information about the default options bundled with the product.

Note

You can order [PPC-CM5-050](#) from the official [Chipsee Store](#) or from your nearest distributor.

Pi[®] CM5 Module

The Pi[®] Compute Module 5 appears in different versions (different RAM size: 2GB, 4GB, or 8GB SDRAM based on CM5 and different eMMC size: 0GB, 16GB, 32GB, or 64GB based on CM5).

The PPC-CM5-050 industrial Pi PC does not include the CM5 Raspberry Pi[®] module by default.

If you would like to purchase it with a CM5, you can select it at the Chipsee store during the ordering process.

Operating System

This product comes with a pre-installed Raspberry Pi OS. Chipsee software engineers have created all the drivers, so every hardware feature is readily available for any standard development tool.

If your project requires a different OS, please [Contact us](#), and we'll make a [customized version](#) that suits your needs.

Specifications

The PPC-CM5-050 industrial Pi PC offers a broad range of performance and connectivity options for scalable integration, providing expandability according to future needs. Some of the key features are listed in the table below.

PPC-CM5-050	
CPU	Raspberry Pi® CM5/CM5Lite; BCM2712 Quad(4) Core Cortex-A76 at 2.4GHz
RAM	2GB, 4GB, or 8GB SDRAM based on CM5
eMMC	0GB, 16GB, 32GB, or 64GB based on CM5
Display	5" IPS LCD, 1280 x 720 px, brightness 400 cd/m ²
Touch	5-point capacitive touch with 1mm Armored Glass
Storage	Support for 1 x TF Card ³
USB	2 x USB 3.0 type-A Host, 1 x USB type-C
LAN	1 x Giga LAN
Audio	3.5mm Audio Out Connector, 2W Speaker Internal
Buzzer	Onboard Buzzer, driven by GPIO
RTC	High accuracy RTC with farad capacitor, can work 1 week after power off (default) . High accuracy RTC with lithium coin battery, can work 3 years after power off <i>(optional)</i> .
RS232	Default to 2 x RS232, up to 4 x RS232
RS485	Default to 2 x RS485 ¹ , these 2 x RS485 can be configured as 2 x RS232
CAN	1 x CAN FD BUS, Arbitration Bit Rate up to 1Mbps, Data Bit Rate up to 8Mbps
GPIO	Not Supported
I2C	Not Supported
WiFi/BT	Optional (Depends on CM5) ²
ZIGBEE	No
HDMI	1 x HDMI-D(Micro HDMI) 2.0, can be driven up to 4K 60FPS
3G/4G/LTE	Not Supported
Camera	Yes, not mounted by default. Available on the board in the embedded PC. Requires a customized case to be exposed in an enclosed PC.
Power Input	6V to 36V
Current	800mA max at 12V, 500mA typical at 12V
Power Consumption	9.6W max, 6W typical

PPC-CM5-050	
Working Temperature	From -20°C to +60°C
OS	Raspberry Pi OS
Dimensions	CS12720RA5050: 138.55 x 84.70 x 27.10mm
Weight	CS12720RA5050: 310g
Mounting Method	CS12720RA5050: Panel, VESA

Table 317 Key Features

-
- 1 The RS485 circuit controls the Input and Output direction automatically, there's no need to control it from within the software.
 - 2 The default product without the CM5 does not include a Wi-Fi/BT module. You can include a CM5 that has the Wi-Fi/BT module at the Chipsee store during the ordering process.
 - 3 TF card slot, **only** used with CM5 Lite to boot system, **cannot** be used as external storage for CM5

Power Input

The PPC-CM5-050 industrial Pi PC can be powered by a wide range of input voltages: 6V to 36V DC. It is a **3 Pin, 3.81mm screw terminal** connector. As shown in the figure below.

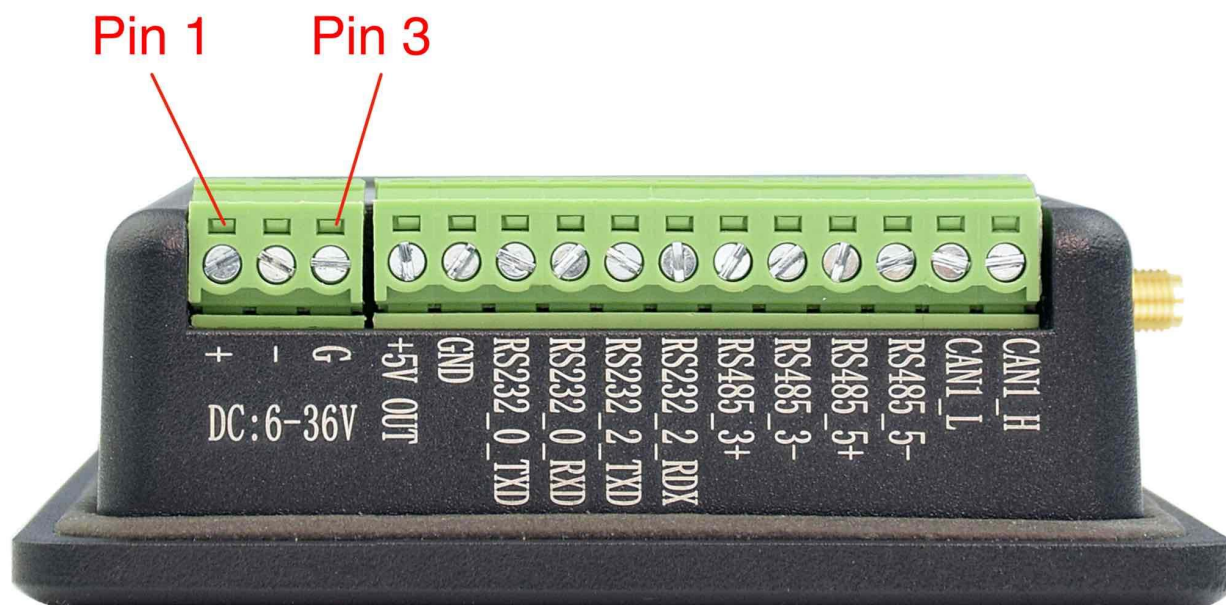

Power Input

Note that the “+” sign represents the positive power input, and it is printed both at the casing and as a silk-screen on the board of the embedded version. The “-” terminal is shorted to the ground.

Power Input Definition		
Pin Number	Definition	Description
Pin 1	Positive Input	DC Power Positive Terminal
Pin 2	Negative Input	DC Power Negative Terminal
Pin 3	Ground	Power System Ground

Table 318 Power Connector

Note

The system ground “G” is connected to power negative “-” on board.

Touch Screen

The PPC-CM5-050 industrial Pi PC uses a 5-point capacitive touch with 1mm Armored Glass screen. However, the Raspberry Pi OS supports only One-Point touch.

The figure below shows the capacitive touch screen connected to the motherboard via the FPC connector.

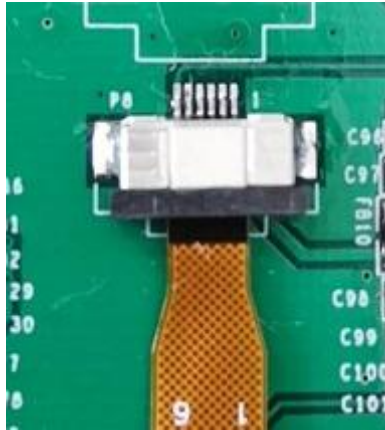

Capacitive Touch Connector

Attention

A capacitive touch screen is susceptible to power noise and Electromagnetic Radiation (EMR). It may cause LCD ripples or even capacitive touch malfunction. If using a capacitive multi-touch test application, you might notice the touch points float erratically across the display. There are several solutions to this problem:

1. Use a high-quality Power Adapter Unit (PSU) with low EMR. You can also provide power from a battery.
2. Make sure that the PPC-CM5-050 Power Input connector (pin 3) is properly connected to the Power System Ground to provide sufficient EMI shielding and eliminate the problem entirely.
3. Bad GND problems can also be confirmed by touching pin 3 of the Power Input connector with one hand while operating the capacitive touch screen with the other hand. In this case, the operator's body acts as the Power System Ground.

Connectivity

There are many connectivity options available on the PPC-CM5-050 industrial Pi PC. It has 2 x USB 3.0 type-A Host, 1 x USB type-C, 1 x Giga LAN (RJ45) Ethernet connector supporting up to 1 Gbps, and 4 x UART and 1 x CAN terminals (RS232/RS485/CAN).

RS232/RS485/CAN

The serial communication interfaces (RS485, RS232, and CAN) are routed to a 12-pin 3.81mm terminal, as illustrated in the figure below.

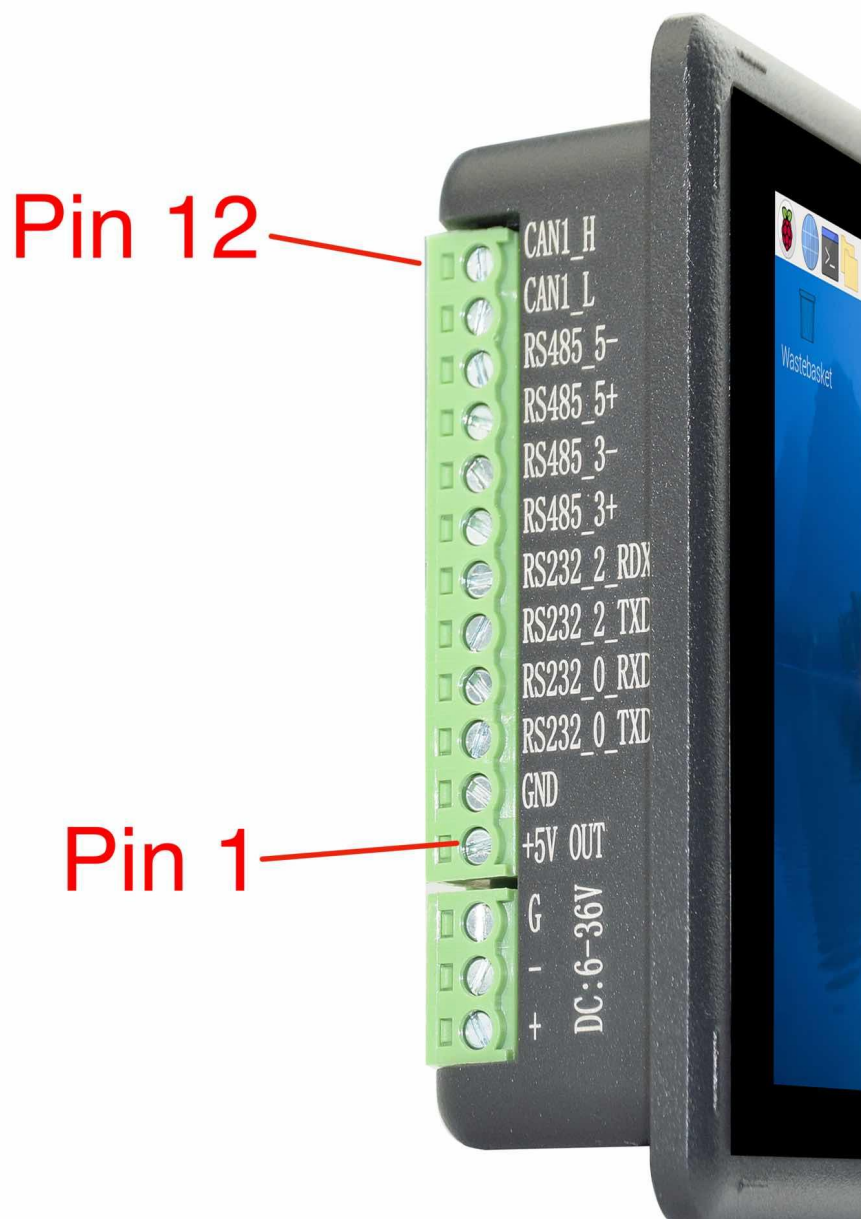

RS232-RS485-CAN on the PPC-CM5-050 Industrial PC

The table below offers more detailed description of every pin and its definition:

Pin Number	Definition	Description	OS Node
Pin 12	CAN1_H	CPU SPI0, CAN H signal	
Pin 11	CAN1_L	CPU SPI0, CAN L signal	CAN0
Pin 10	RS485_5-	CPU UART5, RS485 -(B) signal	
Pin 9	RS485_5+	CPU UART5, RS485 +(A) signal	/dev/ttyAMA4
Pin 8	RS485_3-	CPU UART3, RS485 -(B) signal	
Pin 7	RS485_3+	CPU UART3, RS485 +(A) signal	/dev/ttyAMA2
Pin 6	RS232_2_RXD	CPU UART2, RS232 RXD signal	
Pin 5	RS232_2_TXD	CPU UART2, RS232 TXD signal	/dev/ttyAMA1
Pin 4	RS232_0_RXD	CPU UART0, RS232 RXD signal, Debug Port	
Pin 3	RS232_0_TXD	CPU UART0, RS232 TXD signal Debug Port	/dev/ttyAMA0
Pin 2	GND	System Ground	
Pin 1	+5V	System +5V Power Output, No more than 1A Current output	

Table 319 RS232 / RS485 / CAN Pin Definition

Attention

1. RS485_3 and RS485_5 can control the input and output direction automatically. There's no need to control it from within the software.
2. The 120Ω match resistor for RS485 is **NOT** mounted by default.
3. The 120Ω match resistor for CAN is **NOT** mounted by default. Be sure to mount the match resistor when testing CAN.
4. The 2 x RS485 can be configured to 2 x RS232, if you want a custom configuration, you can contact us when placing an order.

USB Connectors

There are 2 x USB 3.0 type-A Host, 1 x USB type-C onboard, as shown in the figure below.

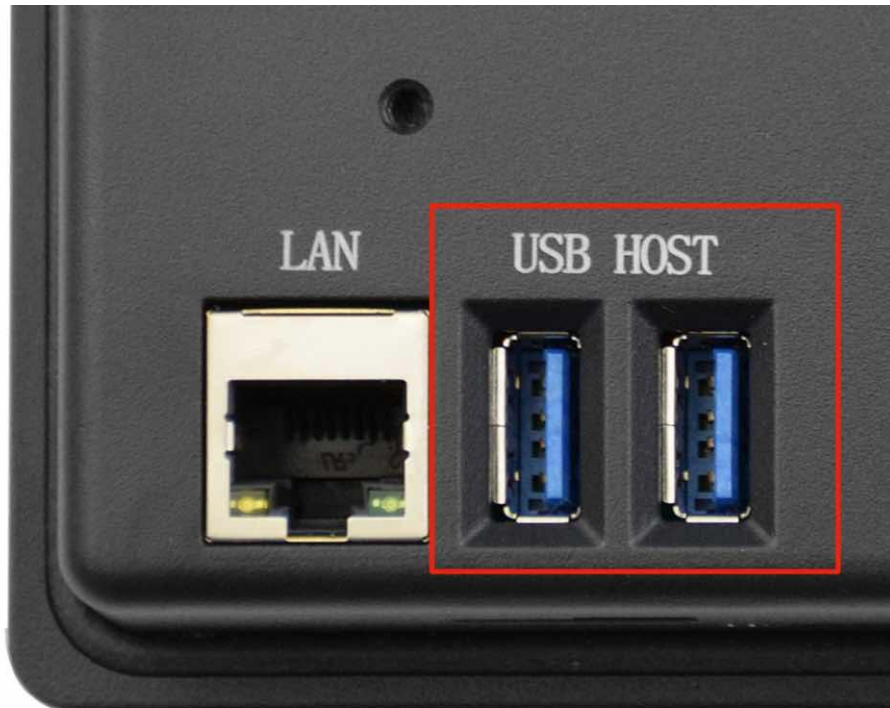

USB HOST Connectors

Attention

1. These two USB host connectors can drive 500mA for each channel at most.
2. These two USB host connectors come from the same USB HUB.
3. When you connect this product to the HOST PC through the Type-C port, the USB HUB will be disabled. As a result, the two USB host connectors will not work.

The product has one USB Type-C OTG connector that works as a slave by default. You can use it to establish a connection with the host PC and for downloading the system to the eMMC of CM5 module.



USB Type-C OTG Connector

Warning

1. Be careful not to touch surrounding electronic components accidentally while plugging in USB devices into the embedded Industrial PC version.
2. Remember to unplug the Type-C cable after flashing OS, otherwise the USB hosts won't work.

LAN

The 1 x Giga LAN provides Ethernet connectivity over standardized Ethernet cables as shown in the figure below. The integrated Ethernet interface supports up to 1 Gbps data throughput. These Giga LAN signals come from the CM5 module directly.

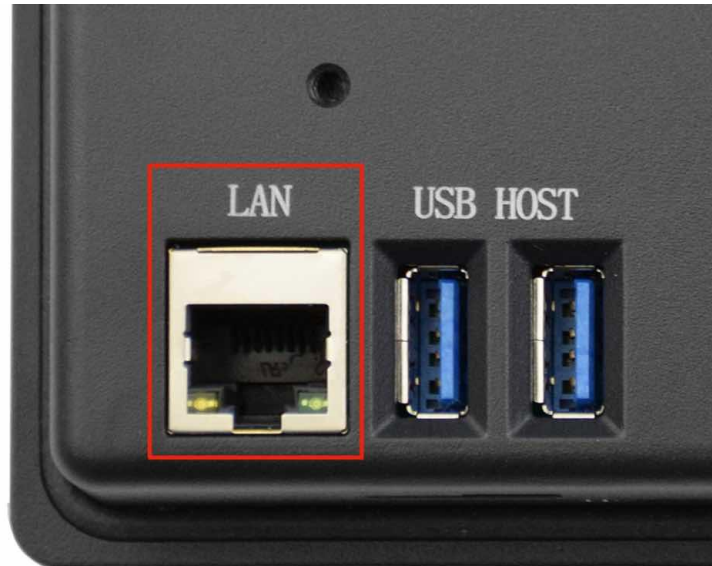

RJ45 LAN Connector

Note

Use CAT5 or better cables to achieve full data throughput over maximum distance defined by the 1000BASE-T standard (100m).

WiFi & BT Module

The default PPC-CM5-050 without the CM5 does not include a Wi-Fi/BT module. If you include a CM5 that has the Wi-Fi/BT module, the product will have Wi-Fi/BT feature. The product also has an SMA connector for an external Wi-Fi/BT antenna:



WiFi+BT Antenna

Attention

The product does not come shipped with the Wi-Fi/BT module by default.

Camera Connector

The PPC-CM5-050 industrial Pi PC has a 22 Pin **Camera Connector**, as shown in the figure below. The camera signals come from CAM1. The table below gives details about the definition of every pin.



Camera Connector

Camera Connector Pin Definition:		
Pin Number	Definition	Description
Pin 1	GND	Power Ground
Pin 2	CAM1_DN0	CSI Negative Channel 0
Pin 3	CAM1_DP0	CSI Positive Channel 0
Pin 4	GND	Power Ground
Pin 5	CAM1_DN1	CSI Negative Channel 1

Camera Connector Pin Definition:		
Pin 6	CAM1_DP1	CSI Positive Channel 1
Pin 7	GND	Power Ground
Pin 8	CAM1_CN	CSI Negative CLK
Pin 9	CAM1_CP	CSI Positive CLK
Pin 10	GND	Power Ground
Pin 11	CAM1_DN2	CSI Negative Channel 2
Pin 12	CAM1_DP2	CSI Positive Channel 2
Pin 13	GND	Power Ground
Pin 14	CAM1_DN3	CSI Negative Channel 3
Pin 15	CAM1_DP3	CSI Positive Channel 3
Pin 16	GND	Power Ground
Pin 17	CAM_GPIO0	CAM GPIO0, use for disable camera power and module
Pin 18	CAM_GPIO1	CAM GPIO1, use for disable camera power and module
Pin 19	GND	Power Ground
Pin 20	SCL0	CPU I2C SCL0 signal
Pin 21	SDA0	CPU I2C SDA0 signal
Pin 22	+3.3V	System +3.3V Power Output, No more than 500mA Current output

Table 320 Camera Connector Pin-out

 **Attention**

1. The camera connector is supported but not mounted by default. It's available on the PCB but not exposed on the case, please contact us when placing an order if you need to use camera on the PPC-CM5-050.

TF Card Slot

The PPC-CM5-050 industrial Pi PC features 1 x **TF Card (micro SD) slot**. A slot can address up to 128GB of memory.



TF (micro SD) Card Slot

Attention

1. The TF card cannot be used for memory extension. It is only used for system boot-up for CM5 LITE model.
2. The product does not come shipped with the TF card by default.

Audio Connectors

The PPC-CM5-050 industrial Pi PC features some audio peripherals. It has 1 x **3.5mm audio output jack**.

Also, the PPC-CM5-050 industrial Pi PC has a miniature 2W internal speaker for audio reproduction, as well as a small buzzer for alarm/notification sounds.



Audio Connector

Attention

By plugging in the headphone cable, the internal speaker will be disabled automatically.

HDMI Connector

The PPC-CM5-050 industrial Pi PC supports 1 x HDMI-D(Micro HDMI) 2.0 interfaces capable of driving 4K displays.



Micro HDMI Connector

PROG Button

The PPC-CM5-050 industrial Pi PC has one button for entering usb download mode, as shown in the figure below.

When booting **with** the button being pressed, the Raspberry Pi will boot from the USB connector. You can use this feature to download the OS software to the internal eMMC.

When booting **without pressing** the button, the Raspberry Pi will boot from the internal eMMC.

There is no need to press the button during regular operation. However, if you need to reinstall the OS, please refer to the detailed information on how to reflash the OS from the [Software Documentation](#).



PROG Button

Mounting Procedure

CS12720RA5050

You can mount CS12720RA5050 with VESA mounting ([guide](#)): **75 x 75 mm**, 2 x **M4** (6mm) screws.

You can mount CS12720RA5050 with PANEL mounting ([guide](#)).

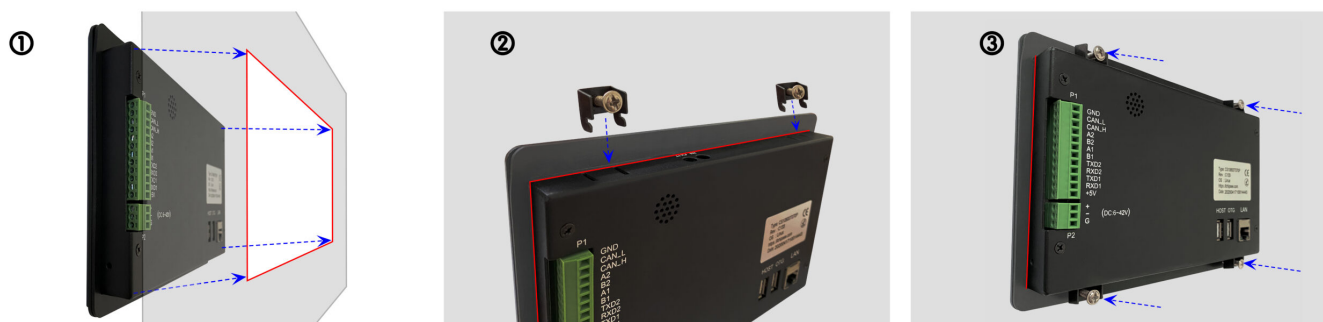

Figure 936: *Panel mounting*

Attention

Please make sure the display is not exposed to high pressure when mounting into an enclosure.

Mechanical Specifications

CS12720RA5050

For CS12720RA5050, the outer mechanical dimensions are 138.55 x 84.70 x 27.10mm (W x L x H).

Please refer to the technical drawing in the figure below for details related to the specific product measurements.

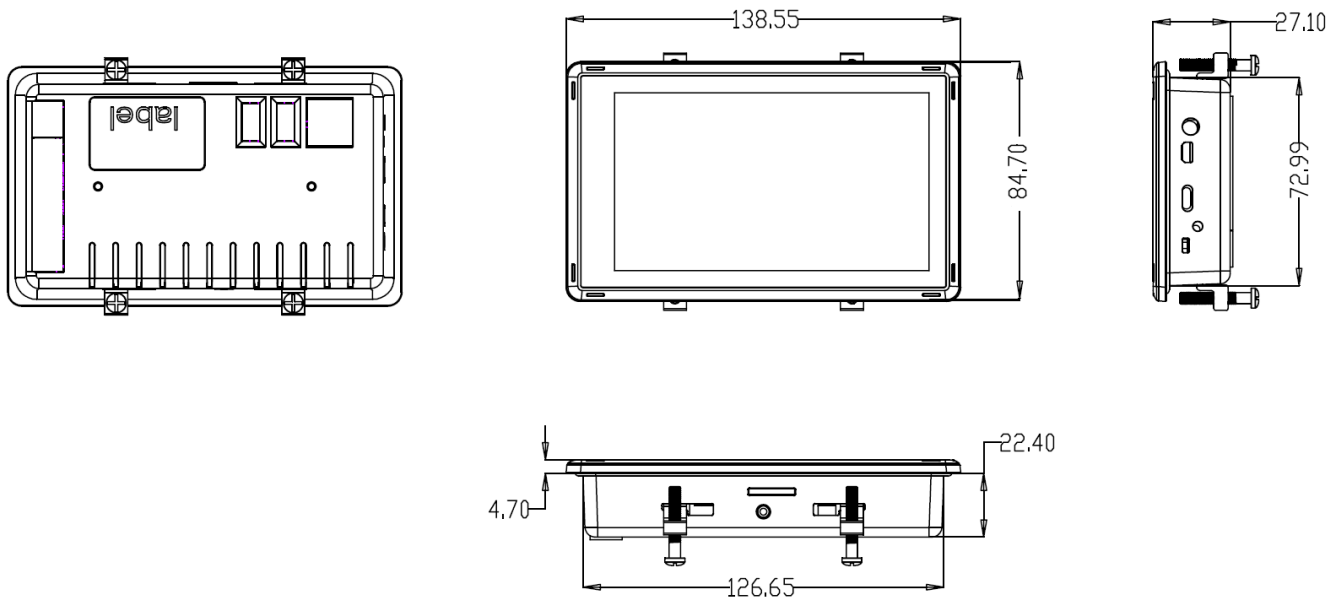

Technical Drawing

3D Model

PPC-CM5-050 3D model can be viewed in the online doc in a web browser, **if you are reading from the PDF** version, please visit the online doc [PPC-CM5-050](#), select hardware documentation, drag the navigation bar to the 3D Model section.

Disclaimer

This document is provided strictly for informational purposes. Its contents are subject to change without notice. Chipsee assumes no responsibility for any errors that may occur in this document. Furthermore, Chipsee reserves the right to alter the hardware, software, and/or specifications set forth herein at any time without prior notice and undertakes no obligation to update the information contained in this document.

While every effort has been made to ensure the accuracy of the information contained herein, this document is not guaranteed to be error-free. Further, it does not offer any warranties or conditions, whether expressed orally or implied in law, including implied warranties and conditions of merchantability or fitness for a particular purpose. We specifically disclaim any liability with respect to this document, and no contractual obligations are formed either directly or indirectly by this document.

Despite our best efforts to maintain the accuracy of the information in this document, we assume no responsibility for errors or omissions, nor for damages resulting from the use of the information herein. Please note that Chipsee products are not authorized for use as critical components in life support devices or systems.

Technical Support

If you encounter any difficulties or have questions related to this document, we encourage you to refer to our other documentation for potential solutions. If you cannot find the solution you're looking for, feel free to contact us. Please email Chipsee Technical Support at support@chipsee.com, providing all relevant information. We value your queries and suggestions and are committed to providing you with the assistance you require.