

235 SERIES

Horizontal Hold Down Clamps | Product Overview

Features:

- Low profile
- Available DESTACO® Toggle Lock Plus™
- Available in stainless steel
- 5 handle colors - see page MC-PRO-7 for details

Applications:

- Assembly
- Checking fixtures
- Welding
- Closures
- Woodworking

Also Available:

See page MC-ACC-1 for accessories
Accommodates M10 or 3/8" spindle accessory

Covered under one or more U.S./International Patents

235-U/USS Flanged Base U-Bar



-USS Stainless Steel Model



235-UR/URSS Flanged Base U-Bar



-URSS Stainless Steel Model

DESTACO®
Toggle Lock
Plus



235-UB ⓘ Straight Base U Bar



235-UF Front Mount Base U-Bar



Color Handles

Available on models in this series that use standard red handles.* Add -Y, -G, -B, -K to end of model number.

*Excludes Toggle Lock Plus levers or dipped handles.

Technical Information

Model	Max. Holding Capacity	Clamp Bar Opening (+10°)	Handle Opening (+10°)	Weight	Accessories (Supplied)	
					Spindle Assembly	Flanged Washers
235-U	3340 N [750 lbf]	92°	70°	0,67 kg [1.47 lb]	240208-M	235106
235-USS	3780 N [850 lbf]				237943-M	235906
235-UR	3340 N [750 lbf]			240208-M	235106	
235-URSS	3780 N [850 lbf]			237943-M	235906	
235-UB ⓘ	3340 N [750 lbf]			0,67 kg [1.47 lb]	240208-M	235106
235-UF				0,92 kg [2.03 lb]	2007208-M	507107

ⓘ This item is available upon request

Holding Capacities

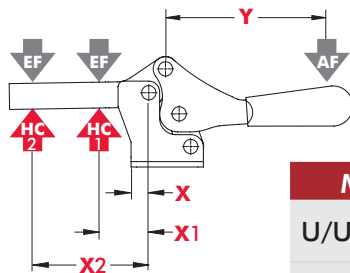

Model	X	X1	X2	Y	‡HC1	‡HC2	‡EF(X1):AF	‡EF(X2):AF
U/UR/UB/UF	[0.25]	[1.75]	[4.13]	[5.75]	[750 lbf] 3340 N	[300 lbf] 1330 N	9:1	5:1
USS/URSS	6,4	44,5	105	146	[850 lbf] 3780 N	[360 lbf] 1600 N		

Dimensions shown "mm [inch]" ‡ HC = Holding Capacity, EF = Exerting Force, AF = Applied Force
See page MC-TEC-4 for additional information.

235 SERIES

Horizontal Hold Down Clamps | Dimensions | -U/-USS/-UR/-URSS/-UB

235-U
Flanged Base
U-Bar

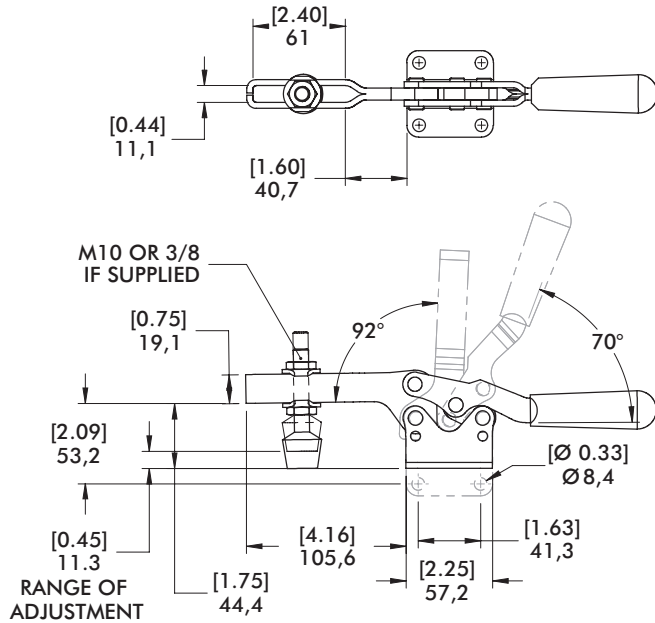
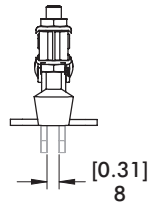

Dimensions | -UR

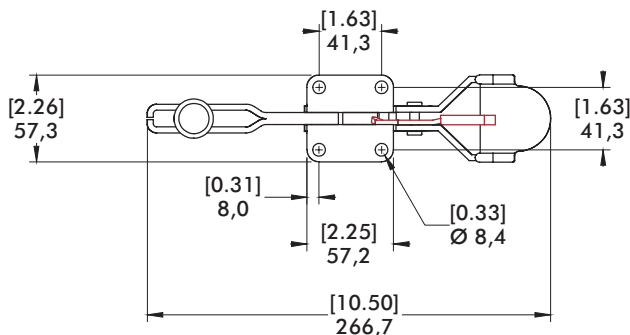
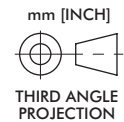
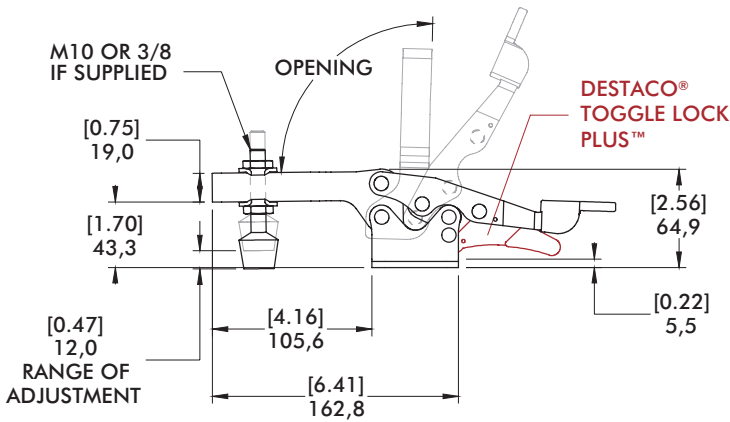
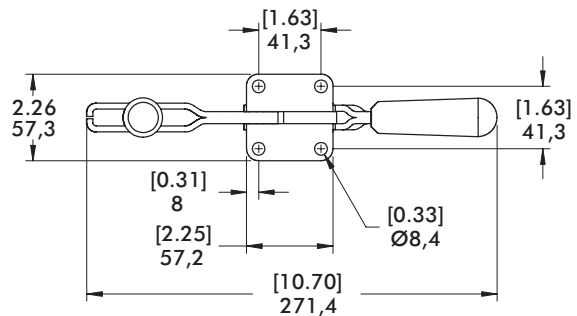
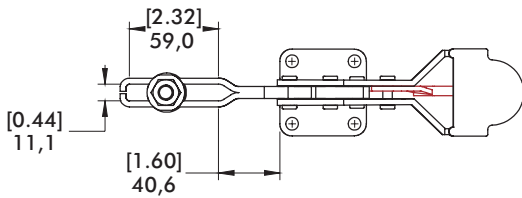

235-UR
Flanged Base
U-Bar
DESTACO®
Toggle
Lock
Plus™



235 SERIES

Horizontal Hold Down Clamps | Dimensions | -UF

235-UF Front Mount Base U-Bar

