



**MEDIATEK**

# Genio 510 Evaluation Kit User Guide

**Version:** 1.3  
**Release date:** 2024-12-12

Use of this document and any information contained therein is subject to the terms and conditions set forth in Exhibit 1. This document is subject to change without notice.

---

## Version History

Version	Date	Description
1.0	2023-12-25	<ul style="list-style-type: none"><li>• First Release</li></ul>
1.1	2024-03-08	<ul style="list-style-type: none"><li>• Modify Android Software Project</li><li>• Modify Flash IoT Yocto address</li></ul>
1.2	2024-05-14	<ul style="list-style-type: none"><li>• Updated 6.1.3 Setup Tool Environment</li></ul>
1.3	2024-12-12	<ul style="list-style-type: none"><li>• Correction from a six-core ARM to a Quad-core ARM</li></ul>

# Table of Contents

<b>Version History</b> .....	<b>2</b>
<b>Table of Contents</b> .....	<b>3</b>
<b>List of Figures</b> .....	<b>4</b>
<b>List of Tables</b> .....	<b>5</b>
<b>1 Overview</b> .....	<b>6</b>
1.1 General Information .....	6
1.2 Architecture and Block Diagram.....	6
1.3 MMD Layout Dimension.....	7
1.4 Feature Summary.....	8
<b>2 Introduction</b> .....	<b>9</b>
2.1 CPU (MT8370) .....	12
2.2 Power Management IC (MT6365) .....	12
2.3 DRAM (Micron MT53E1G32D2FW-046 IT: B) .....	12
2.4 eMMC Storage (WD SDINBDG4-64G-XI2) .....	13
2.5 M.2 Wi-Fi/Bluetooth Module (AzureWave AW-XB468NF) .....	13
2.6 How to Boot the Genio 510 EVK .....	13
2.7 EVK Debug.....	13
<b>3 Interfaces and Connectors</b> .....	<b>15</b>
3.1 Genio 510 EVK Board I/O Connectors .....	15
3.2 System Power Paths .....	16
3.2.1 Charger Power Source.....	16
3.2.2 System Power.....	17
3.2.3 Raspberry Pi Power 3V3.....	17
3.2.4 Auto Power On by plugin of AC Adaptor.....	18
3.3 I/O Interface .....	18
3.4 MicroSD Slot.....	22
3.5 Power and Function Key Interface .....	23
3.6 USB Device .....	23
3.7 USB Host.....	23
3.8 Audio Interface.....	23
3.9 Microphones .....	23
3.10 MIPI DSI Interface.....	24
3.11 MIPI CSI Interface.....	24
3.12 Ethernet Interfaces.....	24
3.13 HDMI Port How to Switch between DPI and Ethernet Interfaces .....	24
3.14 Antenna Connector .....	24
3.15 How to Switch between DPI and Ethernet Interfaces .....	25
<b>4 Camera Daughter Board</b> .....	<b>26</b>
4.1 D2 Camera Daughter Board .....	27
4.1.1 Key Feature and Block Diagram .....	27
<b>5 Power Distribution</b> .....	<b>28</b>
5.1 Power Distribution .....	28
<b>6 Software</b> .....	<b>29</b>

6.1	Android	29
6.1.1	Android Software Project and Configuration	29
6.1.2	How to get Android Software Image	29
6.1.3	Setup Tool Environment	29
6.1.4	Android Software Image Flash method	30
6.2	Yocto	31
6.2.1	Yocto Software Project and Configuration	31
6.2.2	How to Get Yocto Software Image	31
6.2.3	Yocto Software Image Flash Method	32
6.3	How to Install Difference Software into Genio 510 EVK	32
6.3.1	To Flash IoT Yocto	32
6.3.2	To Flash Android	32
<b>7</b>	<b>Appendix</b>	<b>34</b>
7.1	Troubleshooting on Camera Application Icon Disappearance	34
	<b>Exhibit 1 Terms and Conditions</b>	<b>35</b>

## List of Figures

Figure 1-1.	Genio 510 Evaluation Kit System Block Diagram	6
Figure 1-2.	MMD Layout Dimension	7
Figure 2-1.	Genio 510 EVK Board System Setup	9
Figure 2-2.	Genio 510 EVK Board I/O Overview	10
Figure 2-3.	Debug Port	13
Figure 2-4.	UART port setting	14
Figure 2-5.	Log (For reference)	14
Figure 3-1.	System Power Path	16
Figure 3-2.	Jumper Selection for Charger Power Source Input Path	16
Figure 3-3.	Jumper Selection for System Power	17
Figure 3-4.	Jumper Selection for Raspberry Pi Power 3V3 Input	17
Figure 3-5.	Jumper Selection for Auto Power on by plugin of Adapter	18
Figure 3-6.	Configure UART2 Ports	19
Figure 3-7.	Configure Raspberry Pi Ports	22
Figure 3-8.	MT7921 SDIO and MT7663 SDIO Jumper Setting	22
Figure 4-1.	D2 installation	26
Figure 4-2.	D2 Camera Board	27
Figure 4-3.	Block Diagram of D2 Camera Board	27
Figure 5-1.	Power Distribution	28
Figure 6-1.	Flash Tool Window	30
Figure 6-2.	Download Port	31
Figure 7-1.	Factory reset.	34

## List of Tables

Table 2-1. Contains in The Box .....	11
Table 2-2. Key Component List .....	11
Table 2-3. Power Rails .....	11
Table 3-1. Main Board Connectors .....	15
Table 3-2. LED Indicators .....	18
Table 3-3. UART Ports .....	18
Table 3-4. I2C Bus .....	19
Table 3-5. Pin Assignments of the Raspberry Pi like I/O Connector .....	20
Table 3-6. Pin Assignments of the I2S like I/O Connector .....	22
Table 3-7. USB feature in Genio 510 EVK .....	23
Table 3-8. Microphone Input .....	23
Table 3-9. SMA Antenna .....	24
Table 3-10. Pin Mux for DPI and Ethernet RGMII Interface .....	25
Table 4-1. Camera Board Differences .....	26
Table 4-2. Collocation of Camera Board and CAM Connector .....	26
Table 6-1. Android Project name and Configuration .....	29

# 1 Overview

## 1.1 General Information

Genio 510 EVK is an evaluation kit of MediaTek MT8370 platform, integrated with WiFi/Bluetooth (M.2 Module) which is a high performance IoT platform with rich features.

**Note:** Genio 510 EVK is only for development and evaluation, please follow the "MT8370 Baseband Design Notice" document for hardware design rules.

## 1.2 Architecture and Block Diagram

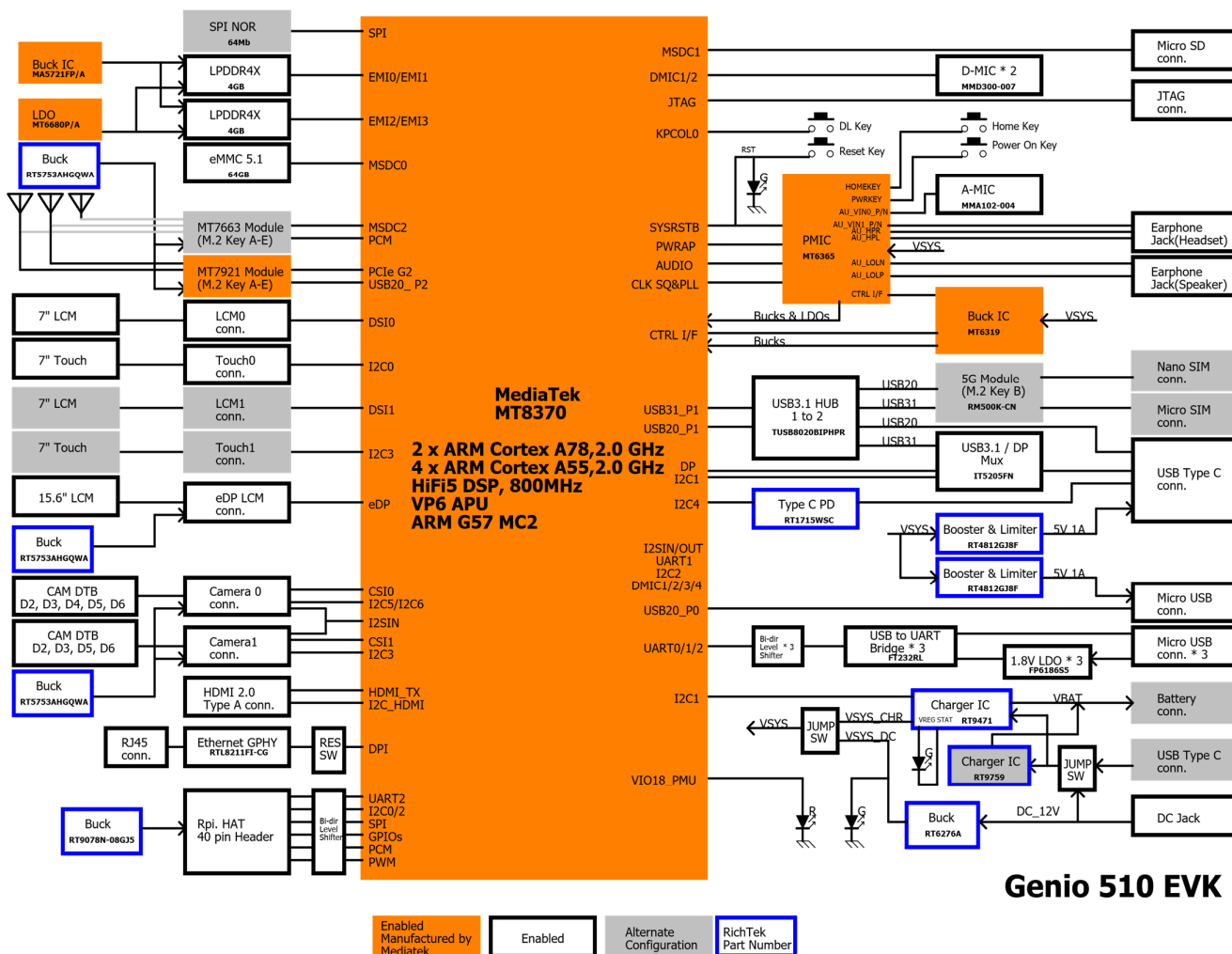

Figure 1-1. Genio 510 Evaluation Kit System Block Diagram

### 1.3 MMD Layout Dimension

- MT8370 + 4-channel DRAM :  $30 \times 40 = 1200\text{mm}^2$
- PMIC MT6365 :  $30 \times 20 = 600\text{mm}^2$
- PMIC MT6319 :  $7 \times 17 = 105\text{mm}^2$

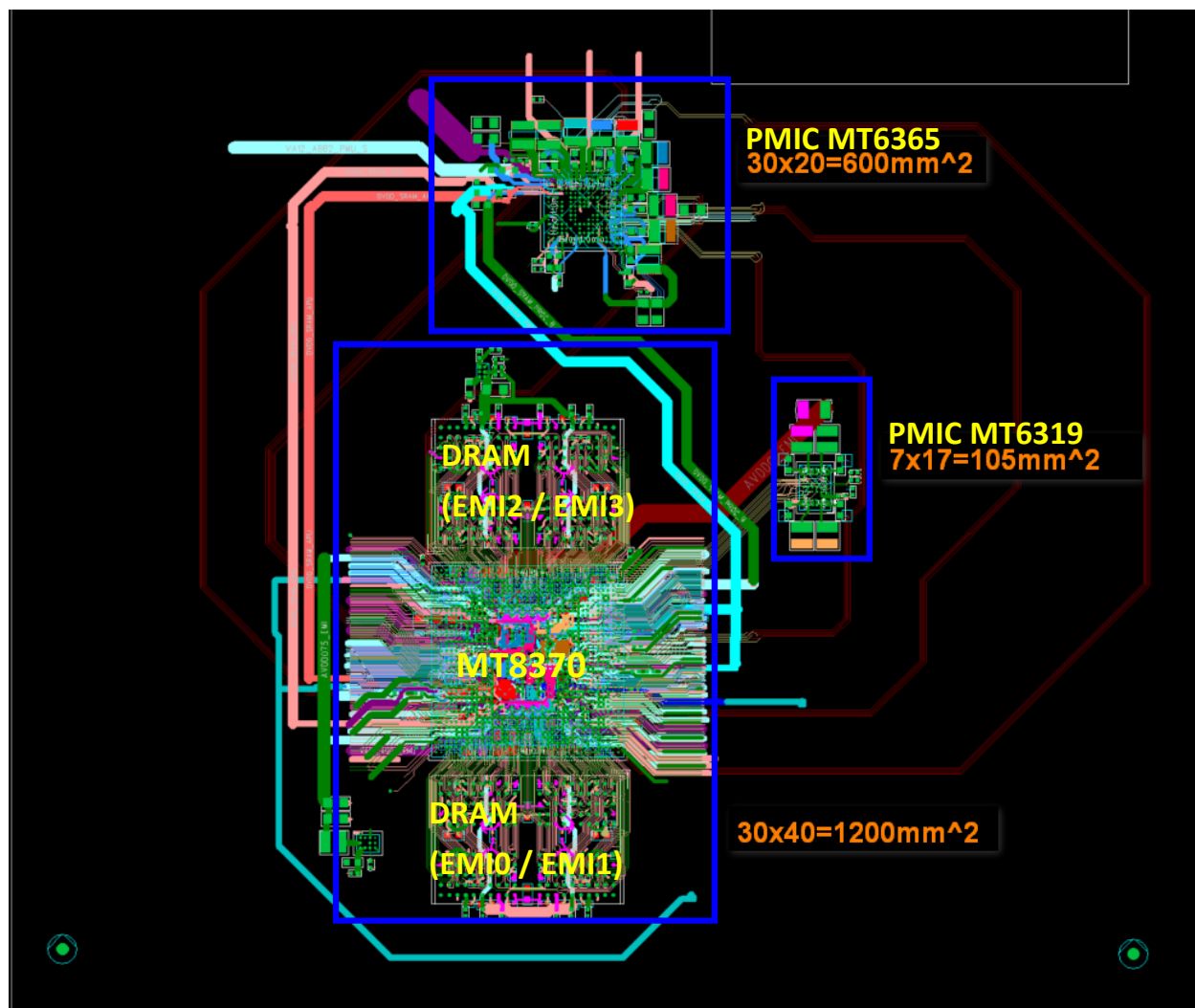

Figure 1-2. MMD Layout Dimension

## 1.4 Feature Summary

- MediaTek CPU (MT8370)
- MediaTek PMIC (MT6365)
- 4GB LPDDR4X RAM (Micron MT53E1G32D2FW-046 IT: B)
- 64GB eMMC5.1 x 1 (WD SDINBDG4-64G-XI2)
- 2.0mm DC Jack x 1 (for 12V DC Input)
- Micro SD Card Slot x 1
- Push Button x 4 (Power, Reset, Download and Home Key)
- LED x 4 (Power, Reset, System on and Charging Status)
- 4-Lane DSI x 2
- eDP x 1
- HDMI2.0 x 1
- 10/100/1000M Ethernet x 1 (Shared with DPI Signal)
- USB Device Port x 1 (Micro USB Connector)
- USB Host Port x 1 (Type-C USB Connector)
- 3.5mm Earphone Jack x 1 (with Microphone Input)
- 3.5mm Line Out Audio Jack x 1
- Analog Microphone x 1
- Digital Microphone x 2
- UART Port x 3 for Trace Log with USB to UART Bridge IC (Micro USB Connector x 3)
- I2C Capacitive Touch Pad
- 4-Data Lane CSI x 2
- M.2 Slot x 2 (for AzureWave AW-XB468NF WiFi Module 、 AW-CB451NF WiFi Module 、 AW-XB554NF WiFi Module)
- 40-Pin 2.54mm Pin Header x 1 (for Raspberry Pi like I/O Interface)
- I2S Pin header

## 2 Introduction

Genio 510 EVK board integrates MediaTek MT8370 processor, 64bit LPDDR4X memory, eMMC, Power Management IC (MT6365) , WiFi/BT M.2 Module.

The package contains a Genio 510 EVK Main board, 7" LCD panel, and a stand set for 7" LCD panel.



**Figure 2-1. Genio 510 EVK Board System Setup**

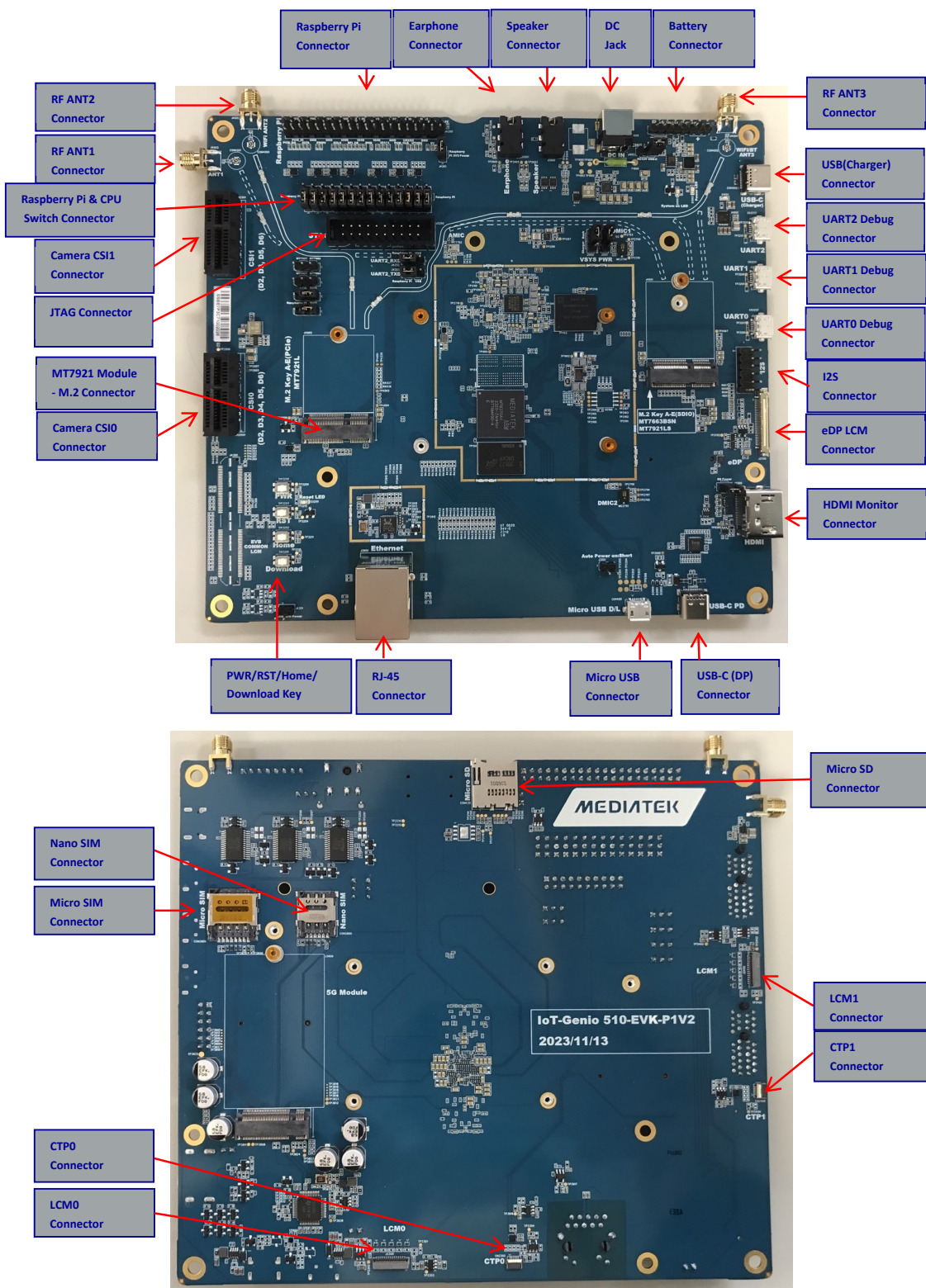

Figure 2-2. Genio 510 EVK Board I/O Overview

Table 2-1. Contains in The Box

No	Part Number or Marking	Item Name	Description	Quantity
1	IoT-Genio 510 EVK-P1V2	Genio 510 EVK Main Board		1
2	IoT-CAM-DTB-D1V2-D2	D2 Camera Board	Camera Daughter Board Using IMX214 Image Sensor	1
3	KD070FHFID078-01-C021A	7" LCD Panel	LCM Module	1
4	M.2 WIFI6 Module AW-XB468NF (IC: MT7921L)	WIFI Module	Installed	1
5	IPEX to IPEX cable		Installed	1
6	IPEX to IPEX cable		Installed	1
7	SMA antenna	WIFI Antenna	Installed	2
8	12V = 4.16A AC adaptor + power cord			1

Table 2-2. Key Component List

Function	Mfr.	PN
Baseband Processor	MediaTek	MT8370
Power	MediaTek	MT6365IBW/B + MT6319LP/A + Discrete Buck/LDO
Charger (Master)	Richtek	RT9471DGQW
Charger (Slave)	Richtek	RT9759WSC
Memory	Micron	MT53E1G32D2FW-046 IT: B
eMMC	WD(SANDISK)	SDINBDG4-64G-X12
Connectivity	AzureWare	AW-XB468NF (MT7921L Module)
LCM	SHENZHEN STARTEK	KD070FHFID078-01-C021A V1.3 (7" LCD Panel)
Camera Module (D2)	御光視覺	WDN01A-100 with IMX214 image sensor
USB3.0 HUB IC	Texas Instruments	TUSB8020BIPHR
Buck for Type-C PD Controller	Richtek	RT1715WSC
Type C USB Mux IC	ITE	IT5205FN/BX
Ethernet PHY	Realtek	RTL8211FI-CG
Crystal	SIWARD	XTL581150-M118-181

Table 2-3. Power Rails

Function	Regulator	Default Voltage (V)
ISP	MT6365IBW/B	0.75
GPU		0.75
CPU_L		0.75
CORE		0.75
APU		0.75
CPU_B	MT6319LP/A	0.75
LPDDR4x VDD2		1.125
LPDDR4x VDDQ		0.6
Buck for System	RT6276AHGQUF	4.2
Buck for DRAM	MA5721FP/A	0.75
Buck for WIFI Module	RT5753AHGQWA	3.3
Buck for eDP	RT5753AHGQWA	3.3
Buck for Camera	RT5753AHGQWA	3.3
Buck for Raspberry Pi	RT9078N-08GJ5	3.3
Boost for USB power	RT4812GJ8F	5
LDO for DRAM	MA6680P/A	1.8

## 2.1 CPU (MT8370)

MediaTek MT8370 processor integrates dual-core ARM® Cortex-A78, 2.0GHz processor and Quad-core ARM® Cortex-A55 2.0GHz MPCore processor equipped with the NEON engine offers processing power necessary to support the latest OpenOs along with its demanding applications such as web browsing, email, GPS navigation, and games.

The features of the MT8370 processor include the following:

- Hexa -Core
- 2 x ARM® Cortex-A78 Operating at 2.0GHz with each core 64KB L1 I-Cache, 64KB L1 D-Cache and 256KB L2 Cache
- 4 x ARM® Cortex-A55 Operating at 2.0GHz with each core 32KB L1 I-Cache, 32KB L1 D-Cache and 128KB Cache
- Shared 2MB L3 Cache
- NEON Processing Engine
- ARM TrustZone Security
- DVFS Technology with Adaptive Operating Voltage from 0.55V to 0.973V
- Tensilica VP6 processor with AI Accelerator (AIA or MDLA– MediaTek Deep Learning Accelerator)
- VFGBA-1204 Package

## 2.2 Power Management IC (MT6365)

MediaTek MT6365 power management IC is a programmable power management IC that integrates 9 buck converters and 33 LDOs to provide all power rails required by SoC and peripherals.

MT6365 adopts the SPI interface and two SRCLKEN control pins to control buck converters, LDOs, and various drivers; it provides enhanced safety control and protocol for handshaking with the processor MT8370.

For system management, it provides the following features,

- 9 Buck Converters
- 33 LDOs
- Precision voltage, temperature, and current measurement fuel gauge
- 26MHz External Crystal for System Clock
- 32.768KHz RTC Oscillator for System Timing
- Watchdog Reset
- Over-current and Thermal Overload Protection
- OVP, UVLO Function
- WFBGA-203 Package

## 2.3 DRAM (Micron MT53E1G32D2FW-046 IT: B)

Genio 510 EVK has One 4GB LPDDR4X memory with the following features.

- Dual Channels with 16-bit Data Bus Width
- Supports self-refresh/ partial self-refresh mode
- Supports dual-rank memory device

## 2.4 eMMC Storage (WD SDINBDG4-64G-XI2)

A 64GB eMMC 5.1 WD SDINBDG4-64G-XI2 is used for code and data storage, via MSDC0 interface of the baseband processor MT8370 with 8-bit width data bus.

## 2.5 M.2 Wi-Fi/Bluetooth Module (AzureWave AW-XB468NF)

MediaTek MT7921L is in AzureWave AW-XB468NF M.2 Module. It supports following features.

- M.2 2230 WiFi Module with Key A-E
- MediaTek MT7921L WiFi Chip
- PCIe/USB Interface
- WiFi 802.11 a/b/g/n/ac/ax
- Dual Band 2T/2R MIMO
- Bluetooth 5.2
- Security WPA/WPA2/WPA3 Personal, WPS 2.0, WAPI
- Integrated LNA, PA and T/R Switch

## 2.6 How to Boot the Genio 510 EVK

Power on Genio 510 EVK board by following steps.

Step 1: **Must install camera board on Genio 510 EVK.**

(If camera app disappears in the desktop of Android OS, please refer to chapter 7 Appendix to know the way to fix it. ).

Step 2: Connect UART0 (CN3200) to the computer via an USB cable. (If you want to see the logs).

Step 3: Plug in the DC 12V power adapter.

Step 4: Long Press PWR button more than 3 seconds

You will see the boot-up picture on LCD display and some trace logs come out from UART0.

## 2.7 EVK Debug

- Micro USB (CN3200)output UART log
- Please install FT232RL driver

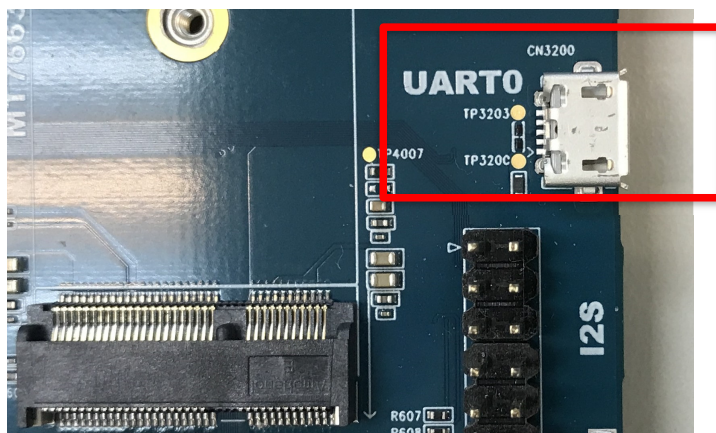

Figure 2-3. Debug Port

- Check PC USB port could recognize the UART device
- Setting serial line (ex. COM57) , serial speed to 921600, choose connection type to serial and press OPEN on putty for Log (Example on Putty)

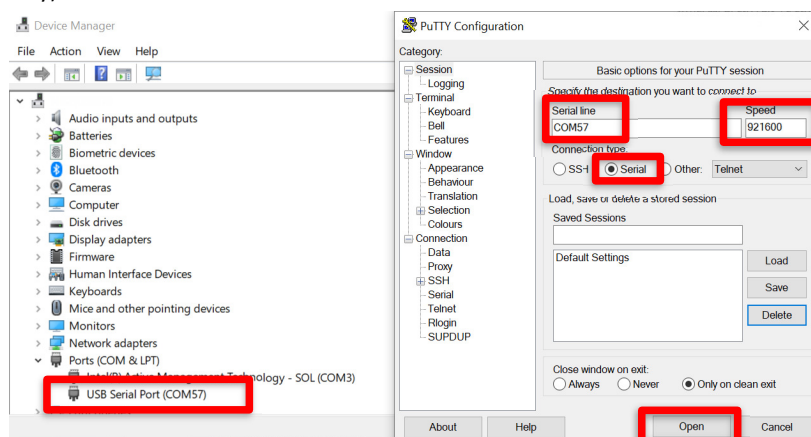

Figure 2-4. UART port setting

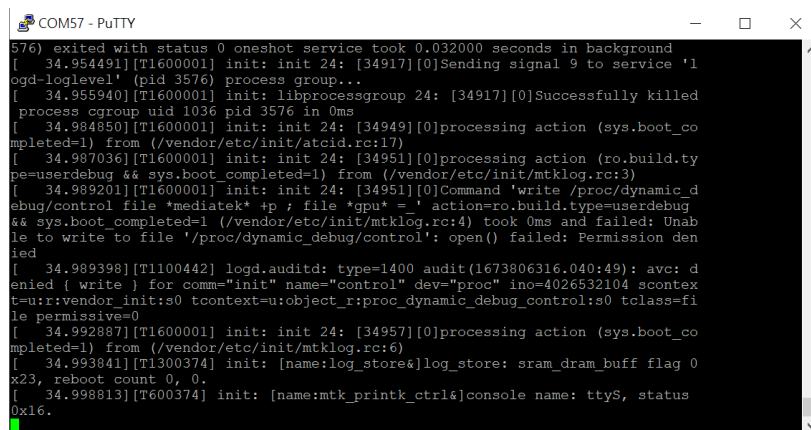

Figure 2-5. Log (For reference)

## 3 Interfaces and Connectors

### 3.1 Genio 510 EVK Board I/O Connectors

**Table 3-1. Main Board Connectors**

Interface	Location	Note
DC Jack	CN1000	12V DC Input
System Power Indicator	D1002	Green LED
Reset Indicator	D3200	Green LED
System On Indicator	D1003	Red LED
Charging Status Indicator	D1001	Green LED
Power On Button	SW3200	
Download Button	SW3201	
Home Key Button	SW3202	
Reset Button	SW3203	
USB Device	CON480	USB2.0 Port
USB3.1/DP MUX	CON490	USB3.1 Port/DP Display Port(MUX)
UART0	CN3200	Debug Port
UART1	CN3201	Debug Port
UART2	CN3202	Debug Port
Micro SD Card Slot	CON420	
DSI	J2300	7" LCM0
DSI	J2400	7" LCM1
Touch	CN2300	7" Touch0
Touch	CN2400	7" Touch1
eDP	J3700	15.6" LCM
CSI0	CN2900	Camera 0 Interface
CSI1	CN2901	Camera 1 Interface
HDMI	J2500	HDMI Type-A Connector
Ethernet	J3900	10/100/1000M Ethernet Transceiver
M.2 Slot Key E	J4000	AW-XB468NF(MT7921L) WiFi Module
Raspberry Pi like I/O	J4200	
JTAG	J3200	
Earphone Jack	J2601	
Line Out	J2600	
Battery Connector	J1002	
Analog Microphone	MIC2702	
Digital Microphone 0	MIC2700	
Digital Microphone 1	MIC2701	

### 3.2 System Power Paths

There are two power supply paths for the system. One is through a buck converter (Richtek RT6276A), which convert 12V (DC Jack) to 4.2V (V<sub>SYS</sub>). This path supports those applications without Li-Polymer batteries.

The other is through a battery charger IC (Richtek RT9471D). This path supports those applications with Li-Polymer batteries.

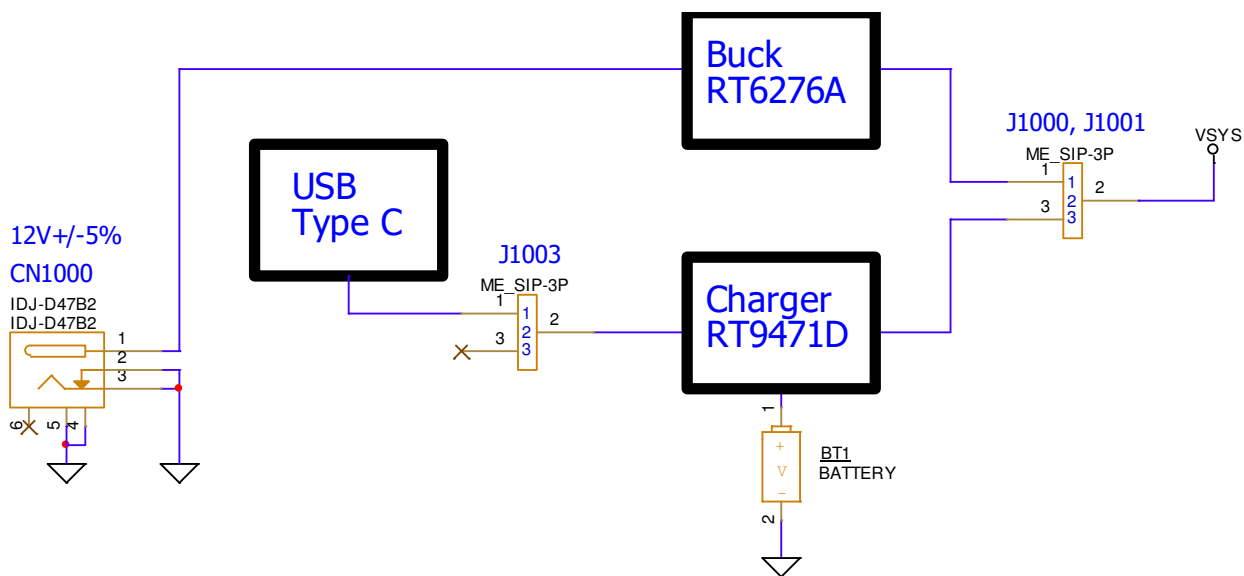

Figure 3-1. System Power Path

#### 3.2.1 Charger Power Source

The user can choose USB type C or DC12V to power the charger ICs by J1003. Usually, any one of them can meet the requirement for most cases.

Current Rating	Charger Power Source
3 Ampere	<p>1-2: USB Type C</p> <p>J1003</p>

Figure 3-2. Jumper Selection for Charger Power Source Input Path

### 3.2.2 System Power

There are two power paths can be selected by J1000 and J1001 (at the same time) for system power VSYS.

Current Rating	System Power
6 Ampere	<p>1-2: Buck</p> <p>J1000 J1001</p>
6 Ampere	<p>2-3: Charger</p> <p>J1000 J1001</p>

Figure 3-3. Jumper Selection for System Power

### 3.2.3 Raspberry Pi Power 3V3

Before using the Raspberry Pi like connector, the J4201 need to plug a Jumper to get power.

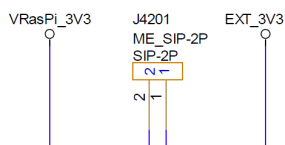

Current Rating	Raspberry Pi Power 3V3
0.3 Ampere	<p>1-2: Raspberry Pi Power 3V3</p> <p>J4201</p>

Figure 3-4. Jumper Selection for Raspberry Pi Power 3V3 Input

### 3.2.4 Auto Power On by plugin of AC Adaptor

Before using Auto Power On function by plugin of AC adaptor, the J3001 need to plug a Jumper.

Current Rating	Auto Power On by plugin of AC Adaptor
0.1 Ampere	<p style="color: blue; text-align: center;">1-2:Auto Power On by plugin of AC adaptor</p>  <p style="text-align: center;">J3001</p>

Figure 3-5. Jumper Selection for Auto Power on by plugin of Adapter

## 3.3 I/O Interface

### LED Indicators

There are four LED indicators.

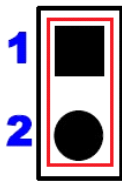
Table 3-2. LED Indicators

LED Indicators	Location	Color	Note
System Power Indicator	D1002	Green	LED is on when system power in.
Reset Indicator	D3200	Green	LED is on when reset key is pressed.
System On Indicator	D1003	Green	LED is on when system is on.
Charging Status Indicator	D1001	Red	LED is on while charging.

### UART

There are three UART (UART0、UART1 and UART2) consoles with USB to UART Bridge ICs (FT232RL) on Genio 510 EVK board. Users can use these consoles for debug purpose. The connectors are Micro USB type.

- Supports word Lengths from 5 to 8 bits with an optional parity bit and 1 or 2 stop bits
- Supports baud rates from 110 bps up to 961,200 bps
- FTDI USB to UART Bridge FT232RL

Table 3-3. UART Ports

UART Port	I/O Connector	Purpose
UART0	CN3200 (Micro USB)	Debug
UART1	CN3201 (Micro USB)	Debug
UART2	CN3202 (Micro USB)	Debug

## Configure UART2 Port

Two Jumper (J4202 and J4203) to select UART2 connect to Micro USB2(CN3202) or Raspberry Pi Conn. (J4200).

Schematic	Description
	(1) Jumper @ 1-2, UART2 = USB
	(2) Jumper @ 2-3, UART2 = Raspberry Pi

Figure 3-6. Configure UART2 Ports

## I2C

- Seven I2C buses (I2C0 to I2C6)
- Supports Master Mode Only
- Adjustable clock speed for LS/FS/FS+ mode operation
- Supports 7-bit address

Table 3-4. I2C Bus

I2C Bus	Purpose	Note
I2C0	Capacitive Touch Controller	Goodix GS9271
	Raspberry Pi I/O	
I2C1	Battery Charger	RT9471D
	Battery Charger	RT9759
	Buck Convertor	MA5721
	USB Type C MUX	IT5205FN/BX
	Audio DTB Connector	
I2C2	Audio DTB Connector	
	Raspberry Pi I/O	
I2C3	Capacitive Touch Controller	Goodix GS9271
	Camera Module CSI1	
I2C4	USB PD Controller	RT1715
I2C5	Camera Module CSI0	
I2C6	Camera Module CSI0	

## SPI

- Support Master/Slave mode
- One chip select output

## PWM

- PWM supports old mode and FIFO mode
- The frequency can be set from 0Hz to 39MHz

## Raspberry Pi like I/O Interface

The pin definitions are as followings:

**Table 3-5. Pin Assignments of the Raspberry Pi like I/O Connector**

Pin #	Description	Note	Pin #	Description	Note
1	3.3V		2	5V	
3	SDA2	GPIO60	4	5V	
5	SCL2	GPIO59	6	GND	
7	IO39		8	TXD2	GPIO35
9	GND		10	RXD2	GPIO36
11	IO0		12	PCM_CLK	GPIO121
13	IO37		14	GND	
15	IO41		16	IO111	
17	3V3		18	IO40	
19	SPI_MO	GPIO81	20	GND	
21	SPI_MI	GPIO82	22	IO38	
23	SPI_CLK	GPIO80	24	SPI_CS	GPIO79
25	GND		26	IO90	
27	SDA0	GPIO56	28	SCL0	GPIO55
29	IO1		30	GND	
31	IO26		32	PWM0	GPIO29
33	CMMCLK2	GPIO30	34	GND	
35	PCM_SYNC	GPIO122	36	IO76	
37	IO28		38	PCM_DI	GPIO124
39	GND		40	PCM_DO	GPIO123

### Note:

- VDD\_5V power can provide 5V/2A maximum but share with Camera \ HDMI 5V output
- EXT\_3V3 power can deliver 3.3V/300mA but share with Audio DTB \ DP MUX and HDMI CEC
- Black words are ground pins
- Red words are power pins
- Green words are special function pins
- Blue words are GPIOs
- Pink words are pins, which multiplex with other function
-

## Raspberry Pi Jumper Setting

Schematic	Description
<p>J4204 ME_SIP-3P</p> <p>[32]JTDI_Connector &gt;&gt; 1 2 &lt;&lt; JTDI [6] RasPi_GPIO39 3</p>	(1) Jumper @ 1-2, JTDI = JTDI Connector (2) Jumper @ 2-3, JTDI = Raspberry Pi
<p>J4205 ME_SIP-3P</p> <p>[32] JTMS_Connector &gt;&gt; 1 2 &lt;&lt; JTMS [6] RasPi_GPIO37 3</p>	(1) Jumper @ 1-2, JTMS = JTMS Connector (2) Jumper @ 2-3, JTMS = Raspberry Pi
<p>J4206 ME_SIP-3P</p> <p>[32] JTRST_Connector &gt;&gt; 1 2 &lt;&lt; JTRST [6] RasPi_GPIO41 3</p>	(1) Jumper @ 1-2, JTRST = JTRST Connector (2) Jumper @ 2-3, JTRST = Raspberry Pi
<p>J4207 ME_SIP-3P</p> <p>[30] CAM1_AVDD28_EN &gt;&gt; 1 2 &lt;&lt; SPIM2_MOSI [7] RasPi_SPI_MO 3</p>	(1) Jumper @ 1-2, JPIM2_MOSI = CAM1 (2) Jumper @ 2-3, JPIM2_MOSI = Raspberry Pi
<p>J4208 ME_SIP-3P</p> <p>[30] CAM1_DVDD_EN &gt;&gt; 1 2 &lt;&lt; SPIM2_MISO [7] RasPi_SPI_MI 3</p>	(1) Jumper @ 1-2, JPIM2_MISO = CAM1 (2) Jumper @ 2-3, JPIM2_MISO = Raspberry Pi
<p>J4209 ME_SIP-3P</p> <p>[30] CAM0_AVDD28_EN &gt;&gt; 1 2 &lt;&lt; SPIM2_CLK [7] RasPi_SPI_CK 3</p>	(1) Jumper @ 1-2, JPIM2_CLK = CAM0 (2) Jumper @ 2-3, JPIM2_CLK = Raspberry Pi
<p>J4210 ME_SIP-3P</p> <p>[36] WIFI_PCM_SYNC &gt;&gt; 1 2 &lt;&lt; PCM_SYNC [7] RasPi_PCM_SYNC 3</p>	(1) Jumper @ 1-2, PCM_SYNC = WIFI (2) Jumper @ 2-3, PCM_SYNC = Raspberry Pi
<p>J4211 ME_SIP-3P</p> <p>[36] WIFI_PCM_CLK &gt;&gt; 1 2 &lt;&lt; PCM_CLK [7] RasPi_PCM_CLK 3</p>	(1) Jumper @ 1-2, PCM_CLK = WIFI (2) Jumper @ 2-3, PCM_CLK = Raspberry Pi
<p>J4212 ME_SIP-3P</p> <p>[24] LCM1_EN &gt;&gt; 1 2 &lt;&lt; I2SIN_D1 [7] RasPi_GPIO111 3</p>	(1) Jumper @ 1-2, I2SIN_D1 = LCM1_EN (2) Jumper @ 2-3, I2SIN_D1 = Raspberry Pi
<p>J4213 ME_SIP-3P</p> <p>[32]JTDO_Connector &gt;&gt; 1 2 &lt;&lt; JTDO [6] RasPi_GPIO40 3</p>	(1) Jumper @ 1-2, JTDO = JTDO Connector (2) Jumper @ 2-3, JTDO = Raspberry Pi
<p>J4214 ME_SIP-3P</p> <p>[32]JTCK_Connector &gt;&gt; 1 2 &lt;&lt; JTCK [6] RasPi_GPIO38 3</p>	(1) Jumper @ 1-2, JTCK = JTCK Connector (2) Jumper @ 2-3, JTCK = Raspberry Pi
<p>J4215 ME_SIP-3P</p> <p>[30]CAM0_DVDD_EN &gt;&gt; 1 2 &lt;&lt; SPIM2_CSB [7] RasPi_SPI_CS 3</p>	(1) Jumper @ 1-2, SPIM2_CSB = CAM0 (2) Jumper @ 2-3, SPIM2_CSB = Raspberry Pi
<p>J4216 ME_SIP-3P</p> <p>[36] JUMP_PCM_DI &gt;&gt; 1 2 &lt;&lt; PCM_DI [7] RasPi_PCM_DI 3</p>	(1) Jumper @ 1-2, PCM_DI = JUMP_PCM_DI (2) Jumper @ 2-3, PCM_DI = Raspberry Pi

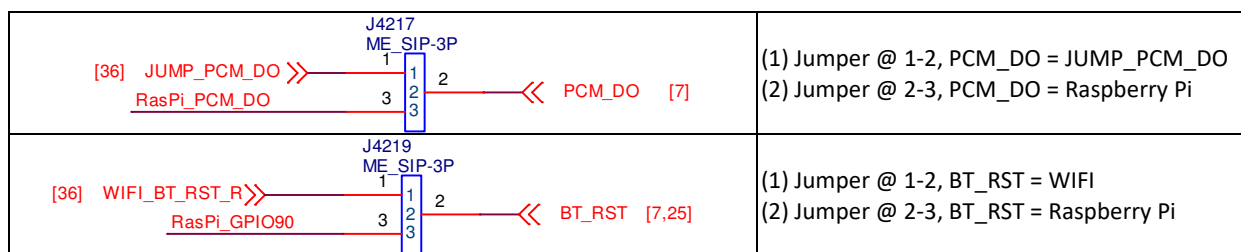

Figure 3-7. Configure Raspberry Pi Ports

### MT7921 SDIO and MT7663 SDIO Jumper

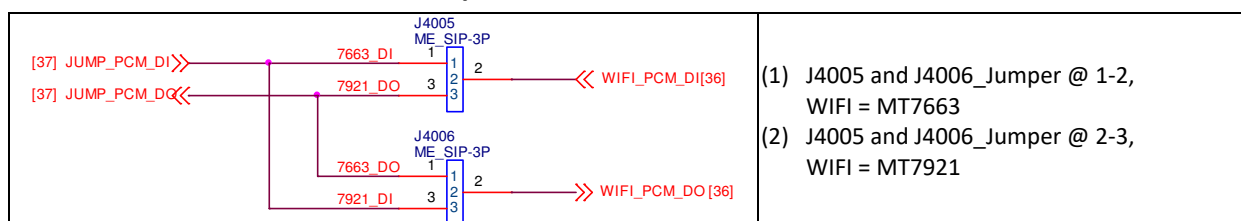

Figure 3-8. MT7921 SDIO and MT7663 SDIO Jumper Setting

### I2S Pin Header like I/O Interface

The pin definitions are as followings:

Table 3-6. Pin Assignments of the I2S like I/O Connector

Pin #	Description	Note	Pin #	Description	Note
1	I2SIN_BCK		2	I2SIN_MCK	
3	I2SIN_DO		4	I2SIN_WS	
5	I2SO2_BCK		6	I2SO2_DO	
7	I2SO2_WS		8	I2SO2_MCK	
9	I2SO2_D1		10	I2SO2_D3	
11	I2SO2_D2		12	GND	

- Black words are ground pins.
- Red words are I2SIN pins.
- Blue words are I2SO2 pins.

## 3.4 MicroSD Slot

Genio 510 EVK board has one MicroSD slot. It uses MT8370 MSDC1 interface and supports following features.

- Default Speed Mode
- High Speed Mode
- SDR12 Mode
- SDR25 Mode
- SDR50 Mode
- SDR104 Mode
- DDR50 Mode
- Support 1bit/4bit SD Bus Width

### 3.5 Power and Function Key Interface

12V power supplies to the system from a 2.0mm DC Jack. Power-on button and Reset button on the evaluation-board to turn on and reboot the system. Home and Download buttons make the operation easier.

### 3.6 USB Device

Genio 510 EVK board has one USB Device port (CON480), which can be used for download and ADB debug, with Micro USB connector.

**Table 3-7. USB feature in Genio 510 EVK**

USB Ports 0	SW support mode	
	Host mode	Device mode
USB2.0	Support	Support

USB Ports 1	SW support mode		Remark
	Host mode	Device mode	
USB3.1 Gen1	Support	Not Support	EVK with Hub
USB2.0	Support	Not Support	EVK with Hub

USB Ports 2	SW support mode		Remark
	Host mode	Device mode	
USB2.0	Support	Not Support	EVK with WIFI

### 3.7 USB Host

Genio 510 EVK board has one USB Host port (CON490) for USB device connection, with Type-C USB connector.

### 3.8 Audio Interface

Genio 510 EVK board provides a 3.5mm earphone jack (with a microphone input) and another 3.5mm audio jack for Line Out (no audio amplifier is built-in).

### 3.9 Microphones

Genio 510 EVK board was designed with one analog microphone (Merry MMA102-004) and two digital microphones (Merry MMD300-007).

**Table 3-8. Microphone Input**

Location	Type	Note
MIC2700	Digital Microphone 1	To Processor MT8370
MIC2701	Digital Microphone 2	To Processor MT8370
MIC2702	Analog Microphone	To PMIC MT6365

### 3.10 MIPI DSI Interface

Genio 510 EVK board provides one 4-lane MIPI DSI interface. A StarTek LCM (KD070FHFID078-01-C021A) with touch pad is provided in the box. The I2C capacitive touch controller is Goodix GT9271.

- Up to 1.2Gbps for 1-Data Lane
- Pixel format of RGB565/RGB666
- Support D-PHY version 1.1

### 3.11 MIPI CSI Interface

Genio 510 EVK board provides two 4-lane CSI interfaces, the CSI interface operates up to a maximum bit rate of 1.5Gbps per lane. Camera sub-boards are connected through Molex 877159006 connector.

### 3.12 Ethernet Interfaces

Ethernet RGMII interface shares some pins with DPI interface. Some configurations should be done before booting up.

- Operate with an external Ethernet PHY (Realtek RTL8211FI-CG)
- Dynamically configurable to support 10/100/1000M with RGMII
- Optional magic packet detection
- EEE (Energy Efficient Ethernet) MII signaling according to the IEEE 802.3az specification
- RJ-45 Ethernet connector with transformer and LEDs in it

### 3.13 HDMI Port How to Switch between DPI and Ethernet Interfaces

Genio 510 EVK board provides an HDMI port, users can connect external displays. The HDMI encoder of the processors MT8370 generate HDMITX format data base on HDMI Specification 2.0b. which support max. frequency up to 594Mhz (4096x2160p@60Hz 8-bit mode)

The HDMI port also supports HPD, EDID, HDCP2.3 and 3D HDMI function.

### 3.14 Antenna Connector

Genio 510 EVK board has three SMA connector. Users can connect them via SMA antenna. At First, three IPEX RF cables must be connected to WiFi module and IPEX Connector (CON4000, CON4001 and CON4002). These antennas are designed for AzueWave M.2 (MT7921L) WiFi module.

**Table 3-9. SMA Antenna**

Location	Band	Note
J4002	2.4GHz / 5GHz	WiFi / BT
J4003	2.4GHz / 5GHz	WiFi / BT
J4004	2.4GHz / 5GHz	WiFi / BT

### 3.15 How to Switch between DPI and Ethernet Interfaces

DPI and Ethernet RGMII Interfaces share some GPIO pins. These two functions cannot exist simultaneously. Reflash code and reboot system might be necessary when you switch between the interfaces. The zero resistors are used to switch these two interfaces, the default configuration is Ethernet.

**Table 3-10. Pin Mux for DPI and Ethernet RGMII Interface**

MT8370 GPIO Table	Ethernet RGMII Net Name	OR Resistor	NM Resistor	DPI	NM Resistor	OR Resistor
GPIO147	GBE_COL	R4401	R4404	DPI_HSYNC_DTB	R4401	R4404
GPIO148	GBE_INTR	R4407	R4410	DPI_VSYNC_DTB	R4407	R4410
GPIO131	GBE_TXD3	R4417	R4418	DPI_D0_DTB	R4417	R4418
GPIO132	GBE_TXD2	R4421	R4423	DPI_D1_DTB	R4421	R4423
GPIO133	GBE_TXD1	R4427	R4428	DPI_D2_DTB	R4427	R4428
GPIO134	GBE_TXD0	R4431	R4432	DPI_D3_DTB	R4431	R4432
GPIO135	GBE_RXD3	R4435	R4436	DPI_D4_DTB	R4435	R4436
GPIO136	GBE_RXD2	R4402	R4405	DPI_D5_DTB	R4402	R4405
GPIO137	GBE_RXD1	R4408	R4411	DPI_D6_DTB	R4408	R4411
GPIO138	GBE_RXD0	R4413	R4415	DPI_D7_DTB	R4413	R4415
GPIO139	GBE_TXC	R4419	R4420	DPI_D8_DTB	R4419	R4420
GPIO140	GBE_RXC	R4425	R4426	DPI_D9_DTB	R4425	R4426
GPIO141	GBE_RXDV	R4429	R4430	DPI_D10_DTB	R4429	R4430
GPIO142	GBE_TXEN	R4433	R4434	DPI_D11_DTB	R4433	R4434
GPIO143	GBE_MDC	R4403	R4406	DPI_D12_DTB	R4403	R4406
GPIO144	GBE_MDIO	R4409	R4412	DPI_D13_DTB	R4409	R4412
GPIO145	GBE_TXER	R4414	R4416	DPI_D14_DTB	R4414	R4416
GPIO146	GBE_RXER	R4422	R4424	DPI_D15_DTB	R4422	R4424

## 4 Camera Daughter Board

There are two camera boards incorporated with Genio 510 main board : D2 camera boards.

**Table 4-1. Camera Board Differences**

	D2 Camera Board
Image Sensor	IMX214-0AQH5-C
Output Format	RAW

**Table 4-2. Collocation of Camera Board and CAM Connector**

	D2 Camera Board
CS10	O
CS11	O

**Note:** "O" means the camera board can be used in this CAM connector, "X" means it cannot.

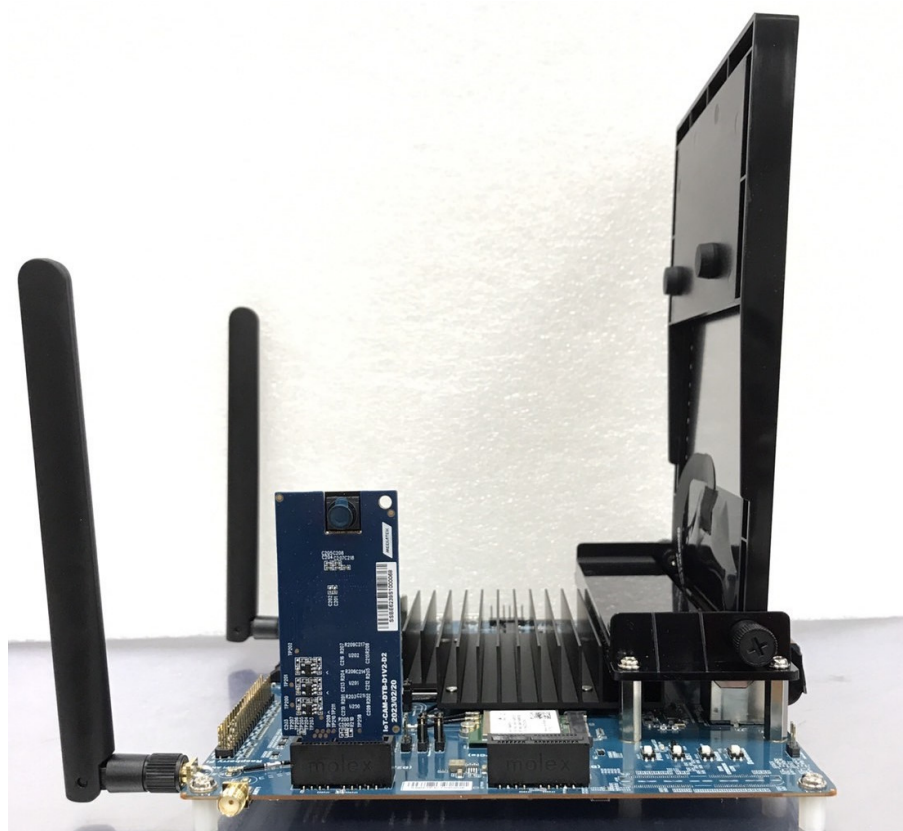

**Figure 4-1. D2 installation**

## 4.1 D2 Camera Daughter Board

The D2 camera Board integrates with a SONY IMX214-0AQH5-C image sensor chip, which is a high-performance camera image processor with rich features.

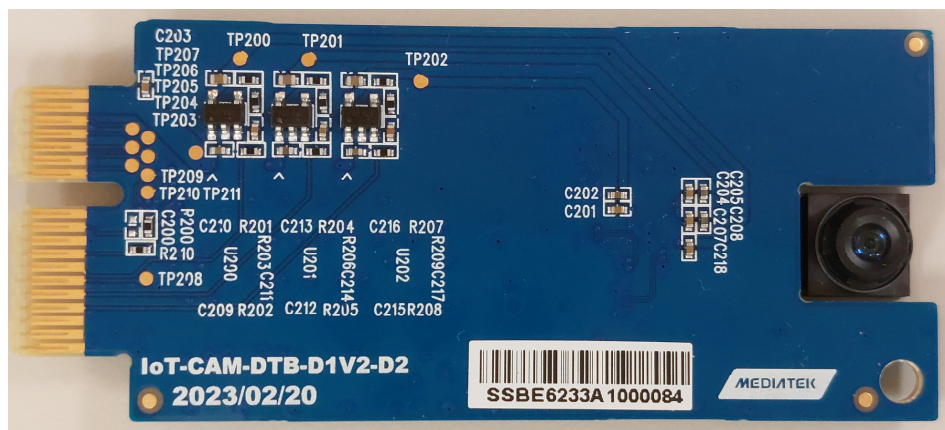

Figure 4-2. D2 Camera Board

### 4.1.1 Key Feature and Block Diagram

- Support 4-Lane MIPI CSI Interface and connect with main board through a 36 pin Gold-Finger. Integrate a 1.0V LDO circuit for camera digital power supply, a 2.8V LDO circuit for camera analog power supply and a 1.8V LDO circuit for camera I/O power supply.

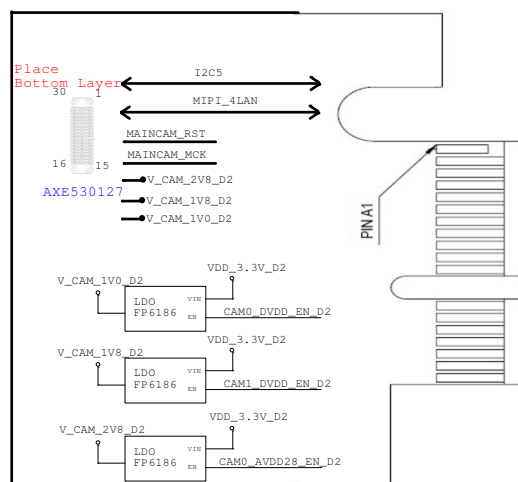

Figure 4-3. Block Diagram of D2 Camera Board

## 5 Power Distribution

### 5.1 Power Distribution

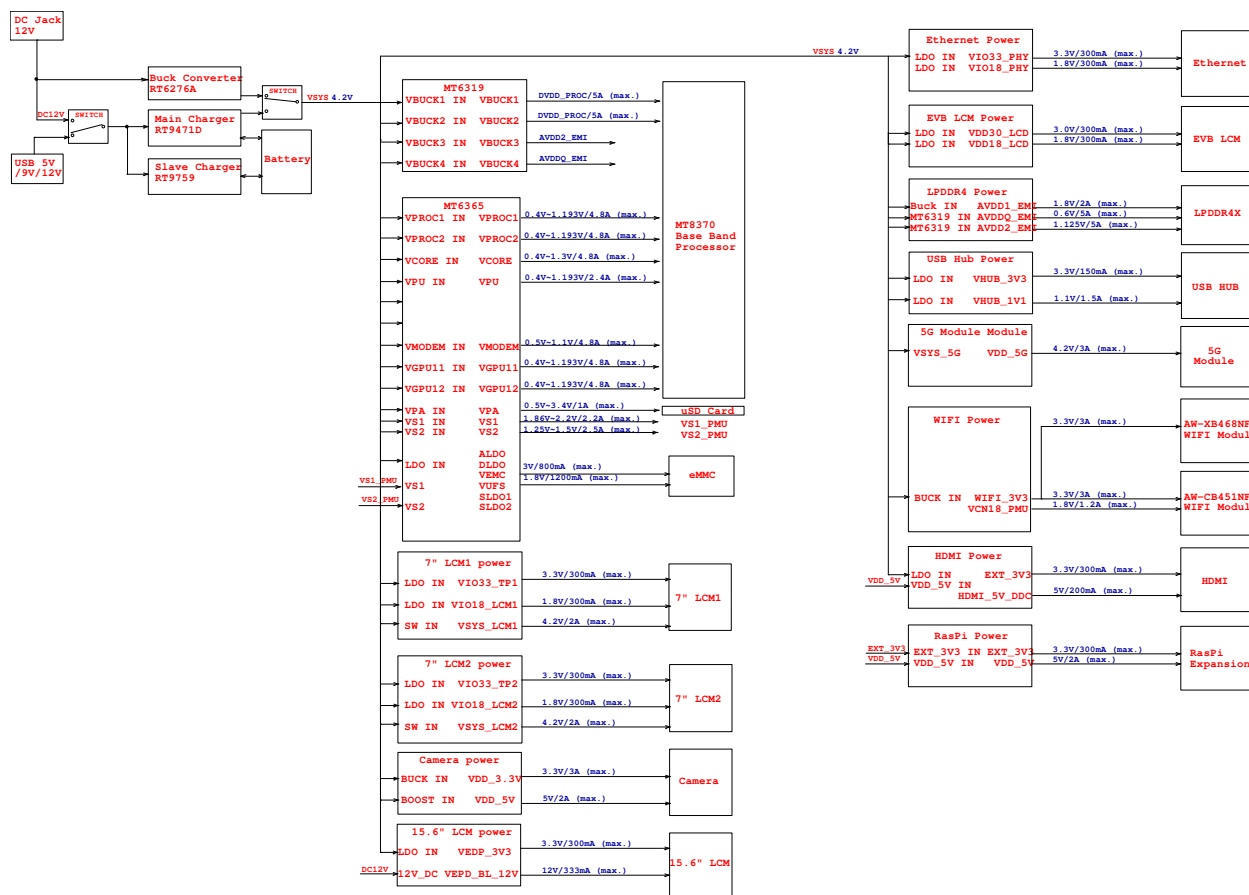

Figure 5-1. Power Distribution

## 6 Software

- Genio 510 EVK is supported by two different software stacks: Android and Yocto. The pre-installed software for Genio 510 EVK is Android.
- Another software stack, IoT Yocto, is also provided as a separate download. The following sections describe how to build, get, and flash the images for Android and Yocto system respectively.

### 6.1 Android

#### 6.1.1 Android Software Project and Configuration

**Table 6-1. Android Project name and Configuration**

Project Name	Configuration
AIoT8370P1_64_BSP	IoT EVK+PCIE MT7921 (J4000)

#### 6.1.2 How to get Android Software Image

Please contact with your VAR, Distributor, MediaTek FAE.

#### 6.1.3 Setup Tool Environment

Download the latest USB driver (Driver\_Auto\_Installer) from Mediatek Online.

<https://online.mediatek.com/apps/tool?id=83013128040570&action=download>

And install Fastboot and ADB Device USB Driver on your Windows environment.

Driver\_Auto\_Installer(Official)\_ALPS > Driver\_Auto\_Installer\_SP\_Drivers\_20230214

名稱	修改日期	類型	大小
DriverInstall.exe	2023/2/14 下午 04:12	應用程式	9,312 KB

### 6.1.4 Android Software Image Flash method

Following steps can reflash the system codes of Genio 510 EVK board.

1. Connect ADB port to PC via Micro USB (CON480)
2. Execute MediaTek Flash Tool
3. Select the proper Download-XML file
4. Select the download mode ("Firmware Upgrade" is preferred.)
5. Start download by pressing the button of "Download"
6. Plug in the DC power cord , the downloader will start

Note:

If the downloader does not start.

Press Download button and plug in the DC power cord will execute a force download.

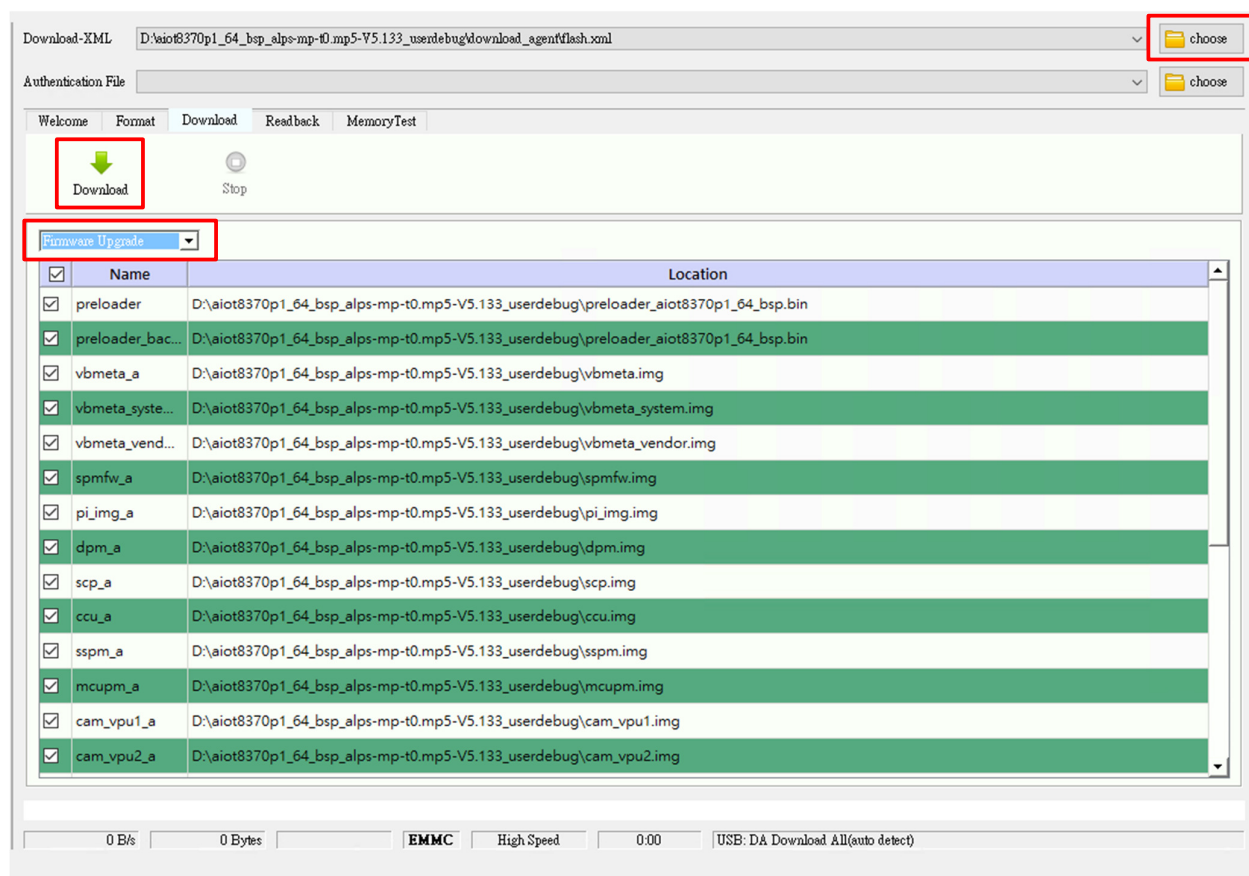

Figure 6-1. Flash Tool Window

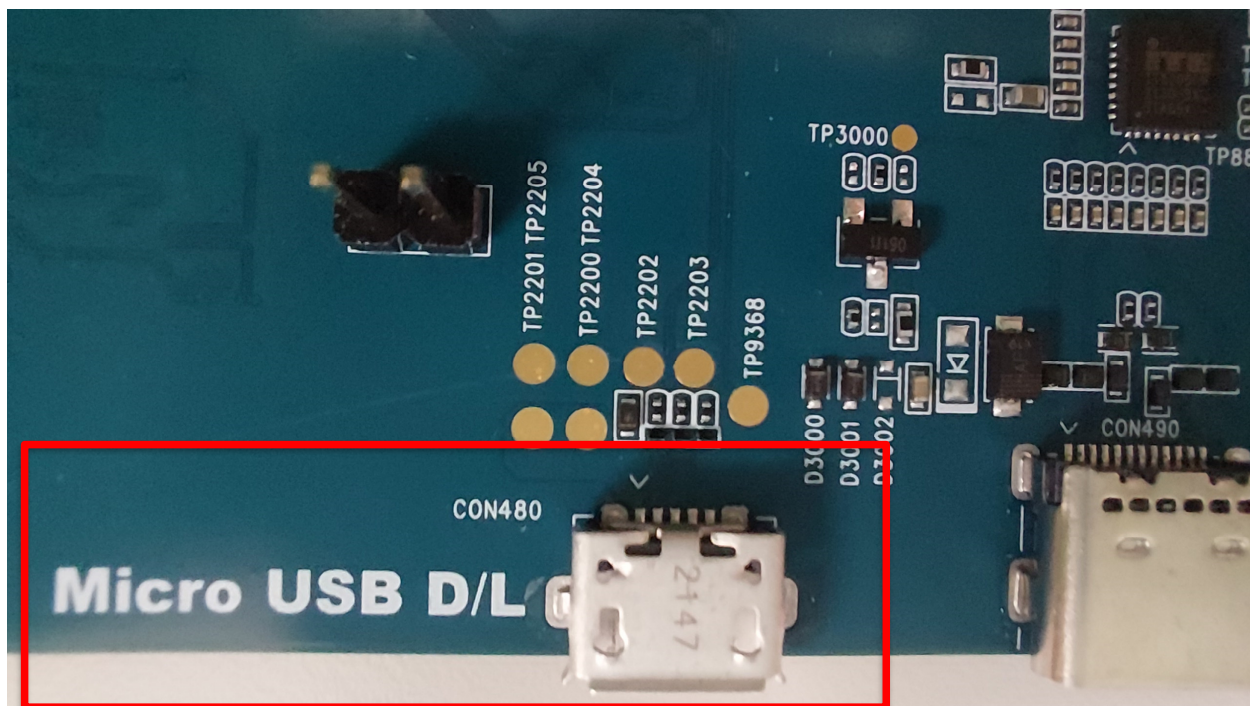

Figure 6-2. Download Port

## 6.2 Yocto

The Yocto software for Genio 510 EVK is IoT Yocto.

Please **note** that the enabled board hardware and supported features of IoT Yocto is different from Android.

For an overview, please refer to: <https://mediatek.gitlab.io/aiot/doc/aiot-dev-guide/>

**Please note that the entire eMMC (except for data stored in eMMC RPMB) will be erased if you flash the board with IoT Yocto images.**

### 6.2.1 Yocto Software Project and Configuration

The build environment for IoT Yocto, and Yocto projects in general, is different from Android. To build Genio 510 EVK with IoT Yocto, you need to setup a Yocto build environment first:

<https://mediatek.gitlab.io/aiot/doc/aiot-dev-guide/master/sw/yocto/get-started/env-setup.html>

After the build environment is ready, set the bitbake MACHINE configuration to genio-510-evk. Please visit the website for detail :

<https://mediatek.gitlab.io/aiot/doc/aiot-dev-guide/master/sw/yocto/get-started/build-code.html#build-images-for-genio-evk-boards>

### 6.2.2 How to Get Yocto Software Image

To download the latest prebuilt board images, please visit:

<https://mediatek.gitlab.io/aiot/doc/aiot-dev-guide/sw/yocto/download.html#prebuilt-board-images>

### 6.2.3 Yocto Software Image Flash Method

IoT Yocto images uses a different tool to flash board images. Please visit the following link to install the flash tool for IoT Yocto on your computer:

<https://mediatek.gitlab.io/aiot/doc/aiot-dev-guide/master/sw/yocto/get-started/env-setup.html>

After the flash tool has been installed, visit this page to flash the downloaded prebuilt image package:

<https://mediatek.gitlab.io/aiot/doc/aiot-dev-guide/master/sw/yocto/get-started/flash.html>

## 6.3 How to Install Difference Software into Genio 510 EVK

Please note that the storage partition layout of Android and Yocto are different, and the boot flow is also different.

### 6.3.1 To Flash IoT Yocto

When flashing IoT Yocto images by referring below gitlab link, **eMMC storage (except for data stored in eMMC RPMB) will be erased**, as the IoT Yocto flash tool always format the storage partitions, making the steps the same regardless the existing image on the board storage.

<https://mediatek.gitlab.io/aiot/doc/aiot-dev-guide/master/sw/yocto/get-started/flash/flash-g700-evk.html#>

### 6.3.2 To Flash Android

To flash Android images to a board with IoT Yocto images already flashed, you'll need to:

A. Configure the “Format” option as “Format whole flash”:

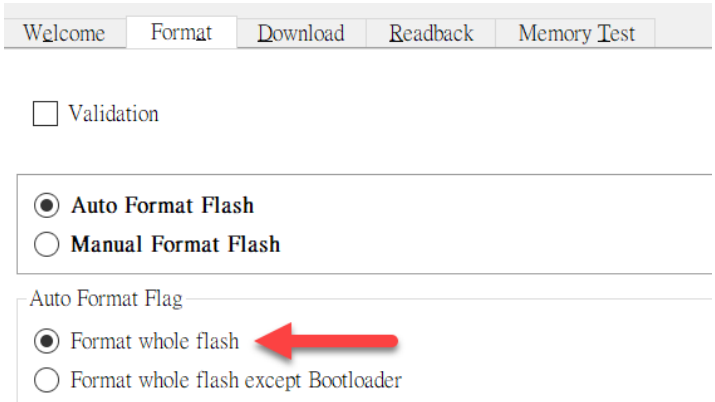

B. Select “Format All + Download” option before flashing the Android image:

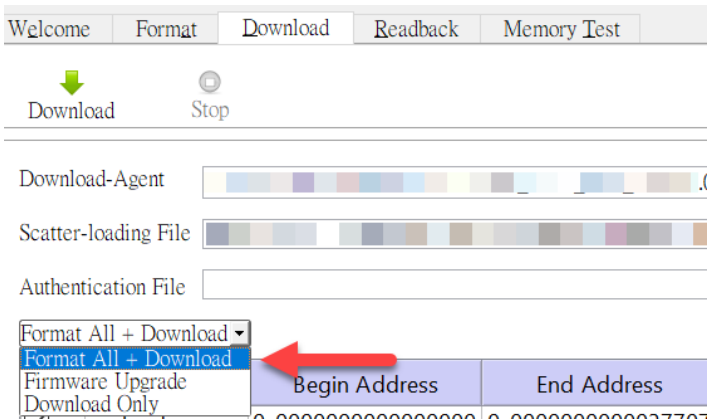

C. You need to manually set the board into “Download Mode” by keeping pressing the “Download” button on the EVK while resetting the board.

## 7 Appendix

### 7.1 Troubleshooting on Camera Application Icon Disappearance

If we lack of installing the camera sensor on the EVK while booting 1st time on Android OS, the camera application icon will disappear, and you can follow the below recovery steps to fix it.

Step:

1. Power off the Genio 510 EVK
2. Install camera Board in Camera CSIO connector or Camera CSI1 connector then power on Genio 510 EVK
3. Execute Factory reset :  
Settings -> System -> Reset options -> Erase all data (factory reset) -> ERASE ALL DATA -> ERASE ALL DATA
4. Genio 510 EVK will auto power on
5. Check the camera function

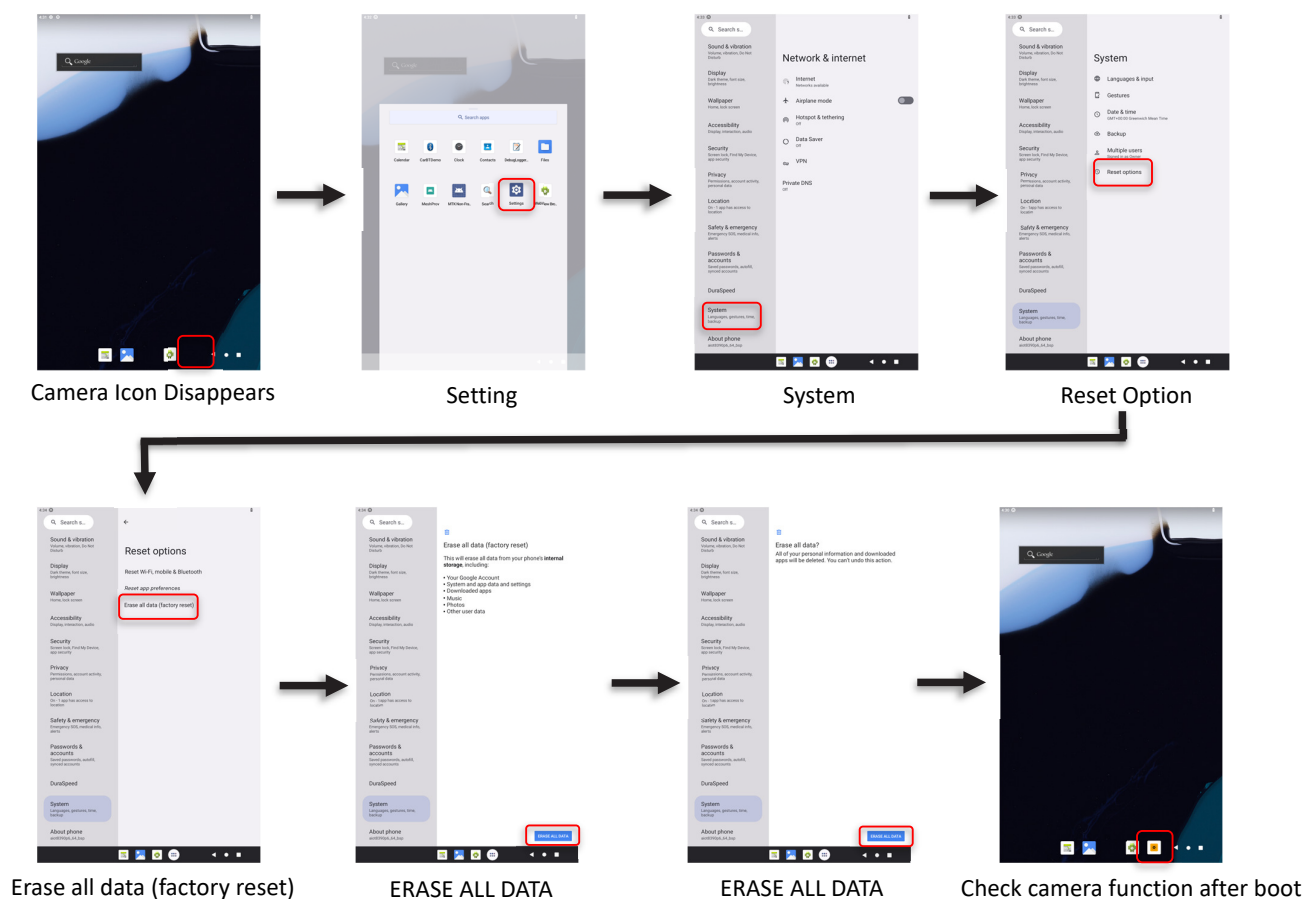

Figure 7-1. Factory reset.

## Exhibit 1 Terms and Conditions

Your access to and use of this document and the information contained herein (collectively this “Document”) is subject to your (including the corporation or other legal entity you represent, collectively “You”) acceptance of the terms and conditions set forth below (“T&C”). By using, accessing or downloading this Document, You are accepting the T&C and agree to be bound by the T&C. If You don’t agree to the T&C, You may not use this Document and shall immediately destroy any copy thereof.

This Document contains information that is confidential and proprietary to MediaTek Inc. and/or its affiliates (collectively “MediaTek”) or its licensors and is provided solely for Your internal use with MediaTek’s chipset(s) described in this Document and shall not be used for any other purposes (including but not limited to identifying or providing evidence to support any potential patent infringement claim against MediaTek or any of MediaTek’s suppliers and/or direct or indirect customers). Unauthorized use or disclosure of the information contained herein is prohibited. You agree to indemnify MediaTek for any loss or damages suffered by MediaTek for Your unauthorized use or disclosure of this Document, in whole or in part.

MediaTek and its licensors retain titles and all ownership rights in and to this Document and no license (express or implied, by estoppels or otherwise) to any intellectual propriety rights is granted hereunder. This Document is subject to change without further notification. MediaTek does not assume any responsibility arising out of or in connection with any use of, or reliance on, this Document, and specifically disclaims any and all liability, including, without limitation, consequential or incidental damages.

THIS DOCUMENT AND ANY OTHER MATERIALS OR TECHNICAL SUPPORT PROVIDED BY MEDIATEK IN CONNECTION WITH THIS DOCUMENT, IF ANY, ARE PROVIDED “AS IS” WITHOUT WARRANTY OF ANY KIND, WHETHER EXPRESS, IMPLIED, STATUTORY, OR OTHERWISE. MEDIATEK SPECIFICALLY DISCLAIMS ALL WARRANTIES OF MERCHANTABILITY, NON-INFRINGEMENT, FITNESS FOR A PARTICULAR PURPOSE, COMPLETENESS OR ACCURACY AND ALL WARRANTIES ARISING OUT OF TRADE USAGE OR OUT OF A COURSE OF DEALING OR COURSE OF PERFORMANCE. MEDIATEK SHALL NOT BE RESPONSIBLE FOR ANY MEDIATEK DELIVERABLES MADE TO MEET YOUR SPECIFICATIONS OR TO CONFORM TO A PARTICULAR STANDARD OR OPEN FORUM.

Without limiting the generality of the foregoing, MediaTek makes no warranty, representation or guarantee regarding the suitability of its products for any particular purpose, nor does MediaTek assume any liability arising out of the application or use of any product, circuit or software. You agree that You are solely responsible for the designing, validating and testing Your product incorporating MediaTek’s product and ensure such product meets applicable standards and any safety, security or other requirements.

The above T&C and all acts in connection with the T&C or this Document shall be governed, construed and interpreted in accordance with the laws of Taiwan, without giving effect to the principles of conflicts of law.