



QLSP23A V1.0
(0402 Amber LED)



Product Outline:

SMD LED lamps from Quelighting are available in miniature sizes and special configurations for automated PC board assembly and space-sensitive applications. These SMD LED lamps are suitable for use in a wide variety of electronic equipment, including cordless and cellular phones, notebook computers, network systems, home appliances, and indoor signboard applications.

Features:

- Compatible with automatic placement equipment.
- RoHS compliant
- Package Dimension = 1.0mmX0.55mmX0.48mm (0402 package)
- Compatible with infrared and vapor phase reflow solder process.
- Custom Bin available upon special request

Application:

- Backlighting in dashboard and switch.
- Telecommunication: indicator and backlighting in telephone and fax.
- Flat backlight for LCD, switch and symbol.
- General use.
- Microdisplays

Compliance and Certification:



Mechanical Property: (Dimension)

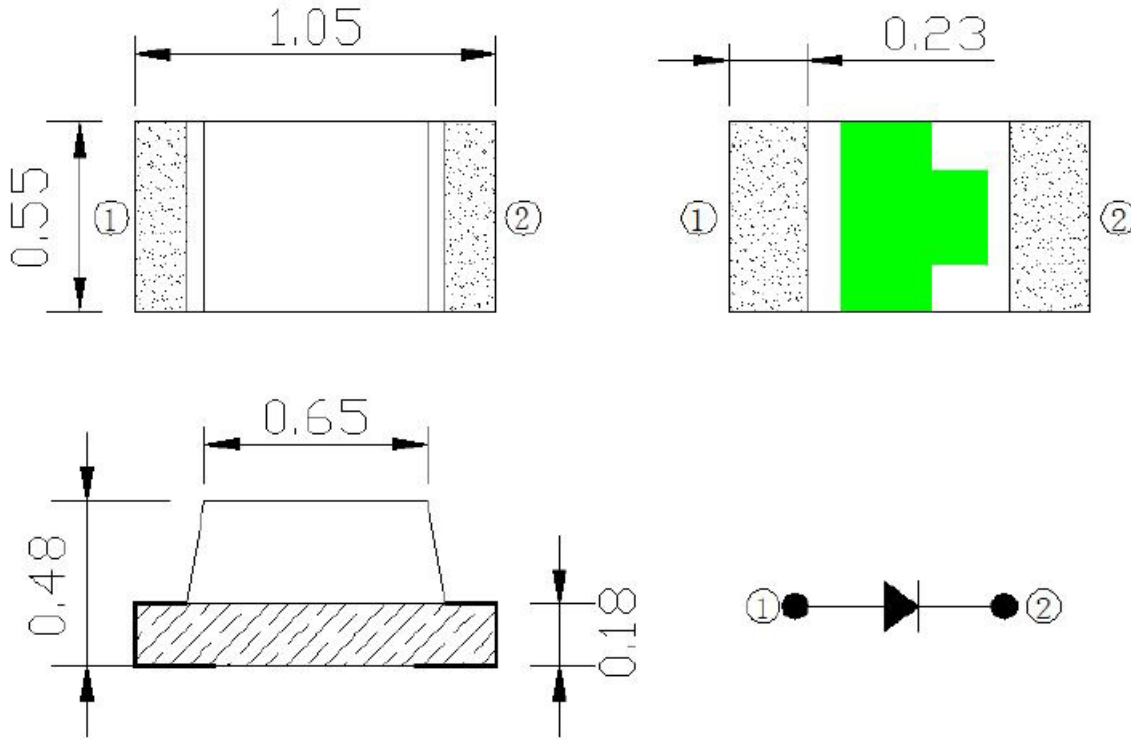

* All dimensions are in millimeters,
* Tolerances are $\pm 0.10\text{mm}$.

Recommended Solder footprint:

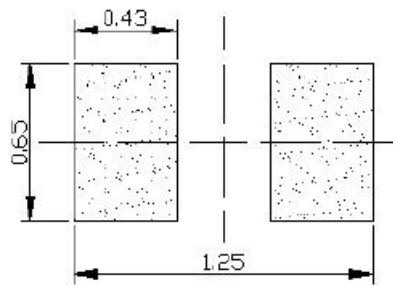

* All dimensions are in millimeters.
* Reflow soldering must not be performed more than twice.



Characteristics

■ Absolute Maximum Ratings

(Ta=25°C)

Parameter	Symbol	Rating	Unit
Reverse Voltage	V_R	5	V
DC Forward Current	I_f	25	mA
Pulse Forward Current (Duty 1/10 @1KHz)	I_{FP}	60	mA
Total Power Dissipation	P_d	55	mW
Electrostatic Discharge (HBM)	ESD	2000	V
Storage Temperature	T_{stg}	-40 ~ 85	°C
Operation Temperature	T_{opr}	-40 ~ 85	°C
Soldering Temperature	T_{sol}	260 < 10 sec	°C

(1) Proper current rating must be observed to maintain junction temperature below maximum at all time

■ Electrical / Optical Characteristic

(Ta=25 oC)

Parameter	Symbol	Min.	Typ.	Max.	Unit	Condition
Luminous Intensity	I_v	71.5		180.0	mcd	If=20mA
Peak Wavelength	λ_p		606		nm	
Dominant Wavelength	λ_d	600		610	nm	
Forward Voltage	V_f	1.9		2.3	V	
View Angle	θ		120		deg	

- (1). Tolerance of Luminous Intensity: ±11%
- (2). Tolerance of Dominant Wavelength ±1nm
- (3). Tolerance of measurement: VF=+/- 0.1V



■ Groups

Forward Voltage (V_F) Bin:

VF Rank (V)				Condition	
Color	Code name	Low	High	unit	
Amber	Q	1.9	2.0	IF=20mA	
	R	2.0	2.1		
	S	2.1	2.2		
	T	2.2	2.3		

Luminous Intensity Bin:

Rank (mcd)				Condition
Color	Code name	Low	High	Unit
Amber	Q	71.5	112.5	IF=20mA
	R	112.5	180	

Dominant Wavelength Bin:

Rank (nm)				Condition
Color	Code name	Low	High	Unit
Amber	A4	600	605	IF=20mA
	A5	605	610	



Characteristic Curves

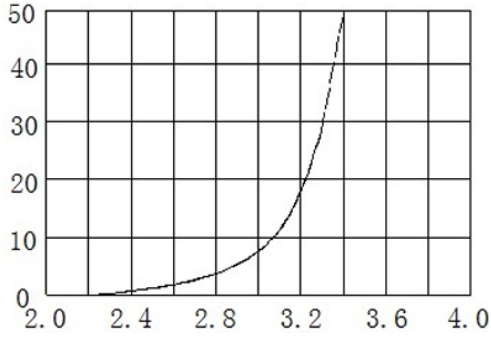

Forward current vs Forward voltage

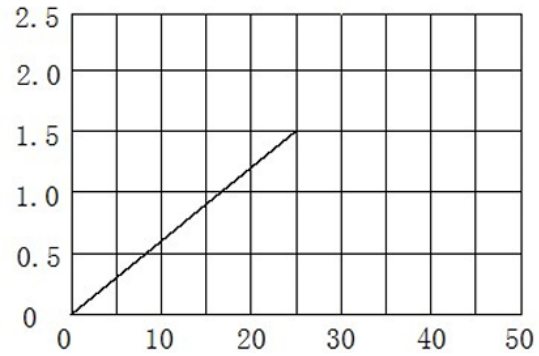

Relative luminous intensity vs forward current

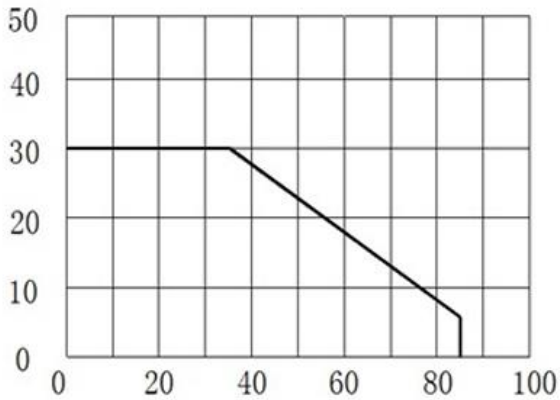

Forward current vs Temp

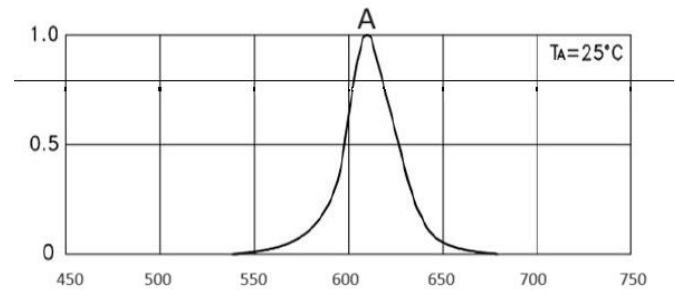

Spectrum Distribution

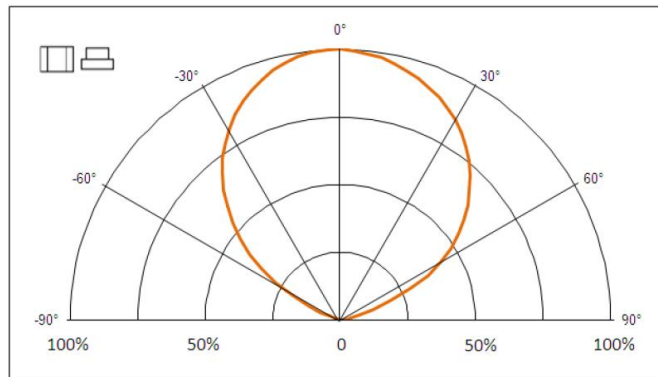

■ Reliability test:

No	Item	Condition	Time/Cycle	Sample size
1	Steady State Operating Life of Room Temperature	25°C Operating	1000 Hrs	20 pcs
2	Steady State Operating Life of Low Temperature -40°C	-40°C Operating	1000 Hrs	20 pcs
3	Steady State Operating Life of Low Temperature 60°C	60°C Operating	1000 Hrs	20 pcs
4	Steady State Operating Life of Low Temperature 85°C	85°C Operating	1000 Hrs	20 pcs
5	Low temperature storage -40°C	-40°C Storage	1000 Hrs	20 pcs
6	High temperature storage 100°C	100°C Storage	1000 Hrs	20 pcs
7	Steady State Operating Life of High Humidity Heat 60°C 90%	60°C/90% Operating	1000 Hrs	20 pcs
8	Steady State Pulse Operating Life Condition	25°C 10Hz duty=1/10 Operating	200 Cycle	20 pcs
9	Resistance to soldering heat on PCB (JEDEC MSL3)	pre-store@60°C, 60%RH for 52hrs Tslid max.=260 10sec	3 Times	20 pcs
10	Heat Cycle Test (JEDEC MRC)	25°C~65°C~-10°C, 90%RH, 24hr/1cycle	10 Cycle	20 pcs
11	Thermal shock	-40°C/ 20min~ 5min~100°C /20min	300 Cycle	20 pcs

■ Judgment Criteria:

Item	Symbol	Test Condition	Judgment Criteria
Forward Voltage	Vf	IF=50 mA	$\Delta Vf < 10\%$
Luminous Flux	Iv		$\Delta Iv < 30\%$



Solder Profile:

-The recommended reflow soldering profile is as follows (temperatures indicated are as measured on the surface of the LED resin):

1. Operating temp.: Above 220 °C ,60 sec.
2. Peak temp.:260 °C Max.,10sec Max.
3. Reflow soldering should not be done more than two times.
4. Never attempt next process until the component is cooled down to room temperature after reflow.
5. The recommended reflow soldering profile (measured on the surface of the LED terminal) is as following:

Lead-free Solder Profile

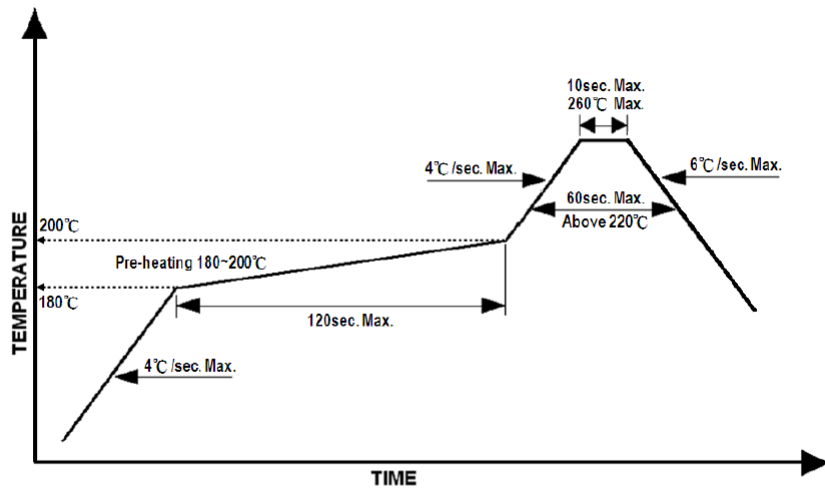

Reworking

- Rework should be completed within 5 seconds under 260°C.
- The iron tip must not come in contact with the copper foil.
- Twin-head type is preferred.



Taping & Packing:

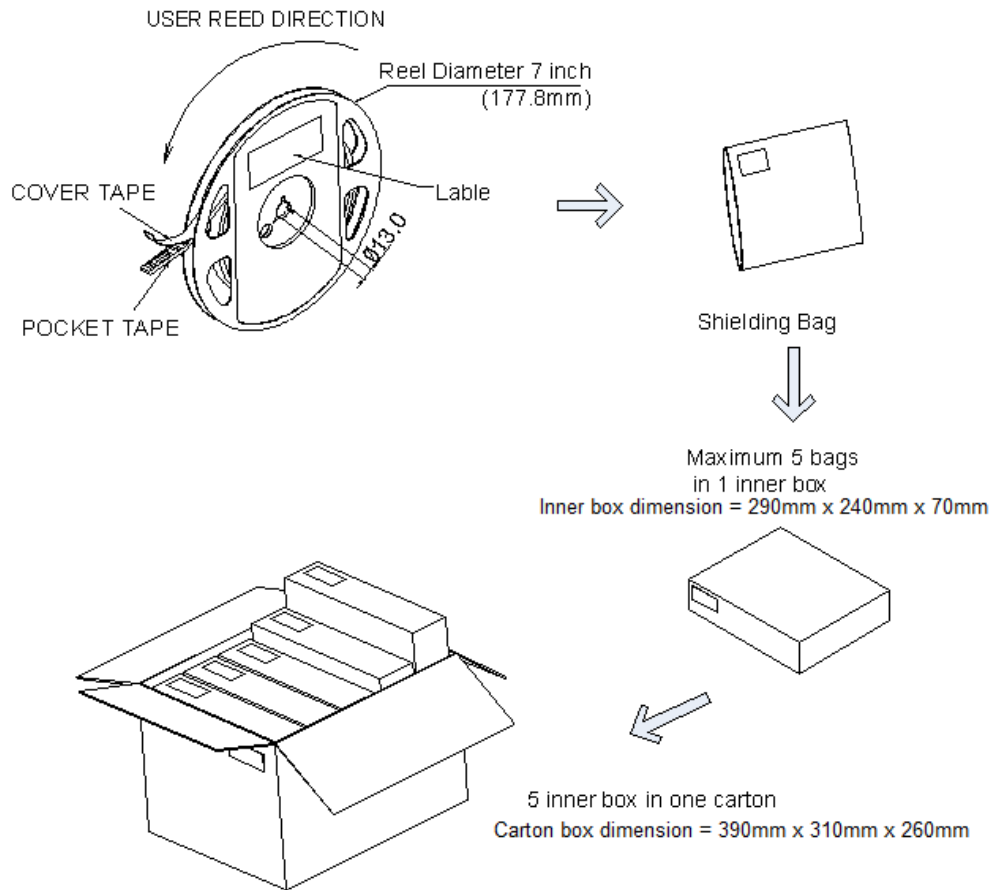
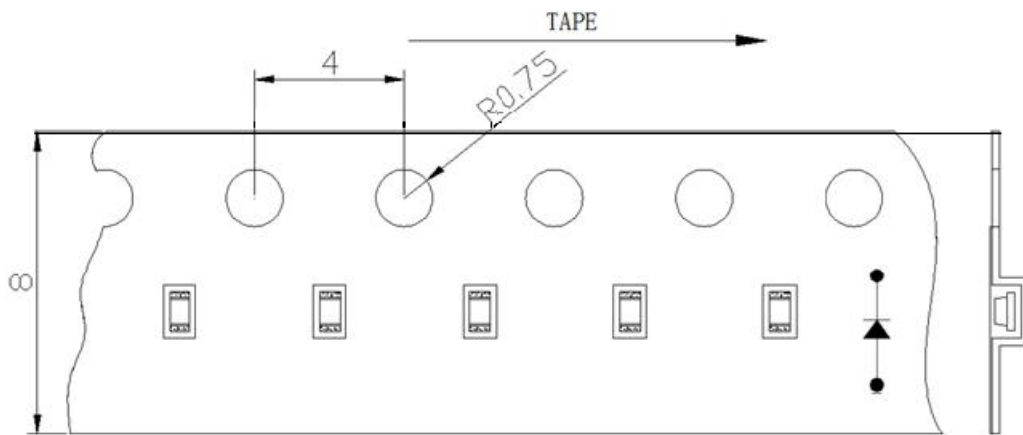

Labeling

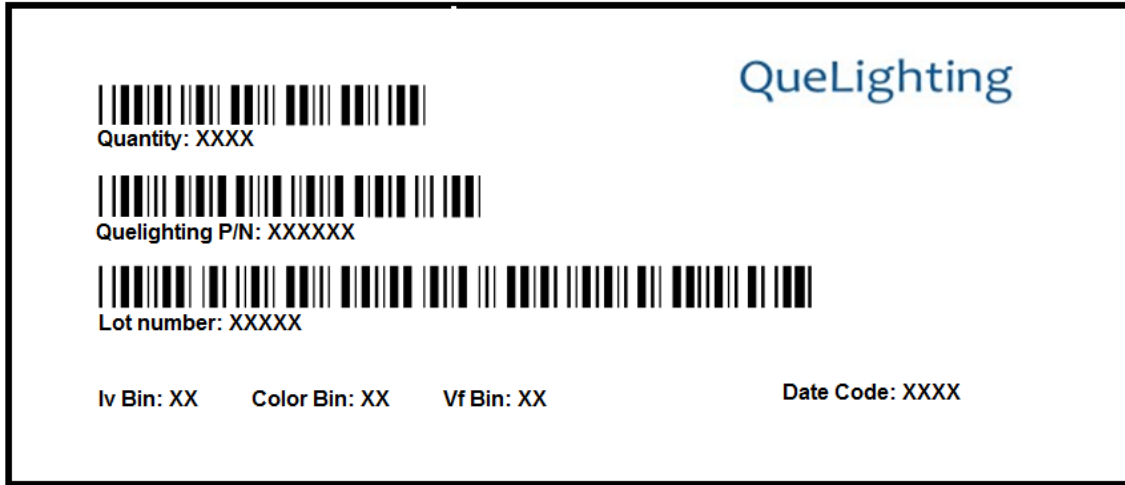

Ordering Information:

Part #	Multiple Quantities	Quantity per Reel
QLSP23A		3000 pcs



Revision History:

Revision Date:	Changes:	Version #:
01-2023	Initial release	1.0

