

1. Characteristics

- Directional from 20 Hz to 20 kHz
 - Dipole polar pattern
 - 4.8 dB diffuse noise rejection
 - >20 dB noise rejection at the null
 - Dual sound ports
- Differential or singled-ended output
- 63.5 dBA SNR
- Low THD:
 - 1% THD at 116 dB SPL
 - AOP at 131 dB SPL (Standard Mode)
 - AOP at 134 dB SPL (High-AOP Mode)
- 115 μ A supply current
- 3.50 x 2.65 mm² footprint
- -40 to 85 °C operating temperature

2. Applications

- Webcams
- AR/VR Devices
- Conferencing Devices
- Boom Microphones
- Headsets
- Wearables
- OTC Hearing Aids
- Automotive

3. Description

The SKR0400 is a directional MEMS microphone with a dipole pickup pattern for superior acoustic signal isolation. The microphone maintains its polar pattern across the audible frequency range. Diffuse noise is attenuated by 4.8 dB across the audible range while direct sound is rejected with >20 dB attenuation at the null.

Packaged in a subminiature 9.3 mm² footprint, the SKR0400 can be used in the most size-constrained applications. The SKR0400 features 63.5 dBA SNR and does not reach 1% THD until 116 dB SPL, despite its small size. This large dynamic range ensures high-quality voice pick-up in both near-field and far-field applications. The SKR0400 dramatically improves both noise and directional performance over conventional omnidirectional microphone arrays.

Pairing multiple SKR0400 microphones enables designers to implement traditional DSP and machine learning-based algorithms. These algorithms maximize the performance of the end product with enhanced beamforming and spatial understanding of the sound field. Additionally, SKR0400 microphones bring true stereo capture to small form factor consumer devices when configured in a Blumlein pair.

4. Functional Block Diagram

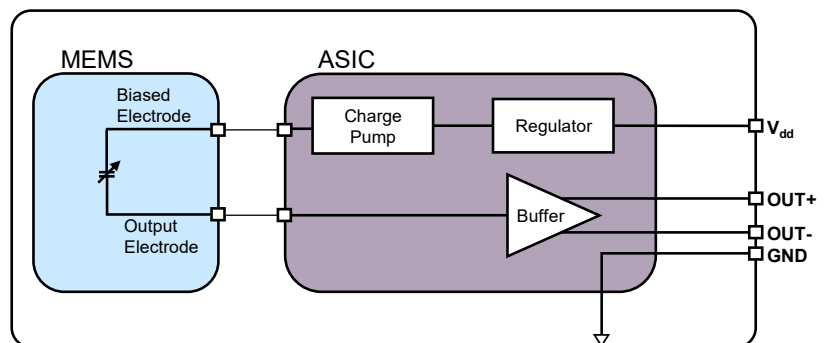

Figure 4.1: Functional block diagram

5. Table of Contents

1. Characteristics	1
2. Applications.....	1
3. Description	1
4. Functional Block Diagram	1
5. Table of Contents.....	2
6. Typical Application Circuit.....	3
7. Specifications.....	4
7.1 Acoustic and Electrical Specifications	4
7.2 Absolute Maximum Ratings.....	5
7.3 Specification Calculation Details	6
7.4 Performance Curves.....	7
8. Mechanical, Packaging, and Manufacturing Information.....	9
8.1 Mechanical Dimensions and Product Marking.....	9
8.2 Land Pattern and Solder Stencil.....	9
8.3 CAD Models	10
8.4 Packaging and Ordering Information	10
8.5 Reflow Profile and Handling Instructions	11
9. Reliability Specifications.....	12
10. Device and Documentation Support	12
11. Revision History	12

6. Typical Application Circuit

The microphone has two operating modes: standard mode and high-AOP mode. To configure the microphone in standard mode, set V_{dd} between 1.6 V and 2.0 V. To configure the microphone in high-AOP mode, set V_{dd} between 2.2 V and 3.6V. The microphone cannot be operated with V_{dd} between 2.0 V and 2.2 V.

A 0.1 μF capacitor should be placed between V_{dd} and GND as close to the microphone as possible to reduce supply noise. A capacitor C_{out} should be used to block the microphone output DC from the application processing input. This capacitor creates a high-pass filter according to $C_{out} = 1/\pi f_c R_{AP}$ (e.g. 80 nF), where f_c (e.g. 20 Hz) is the desired cutoff frequency and R_{AP} (e.g. 100 k Ω) is the application processor resistance.

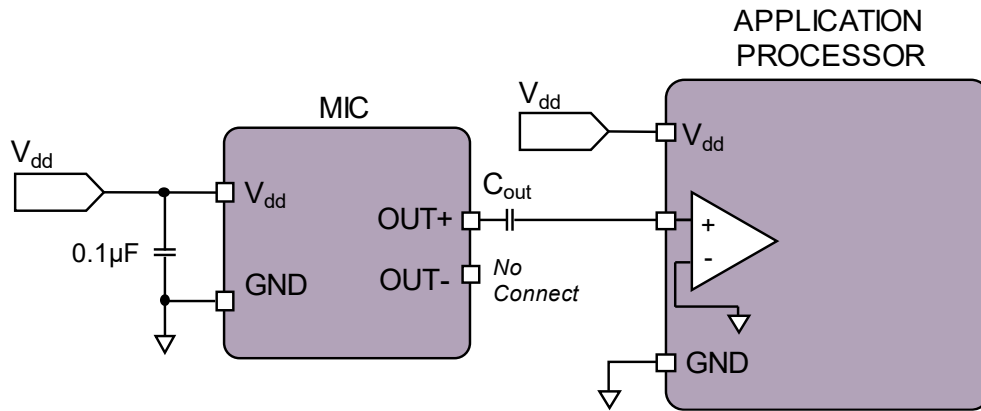

Figure 6.1: Typical single-ended application circuit

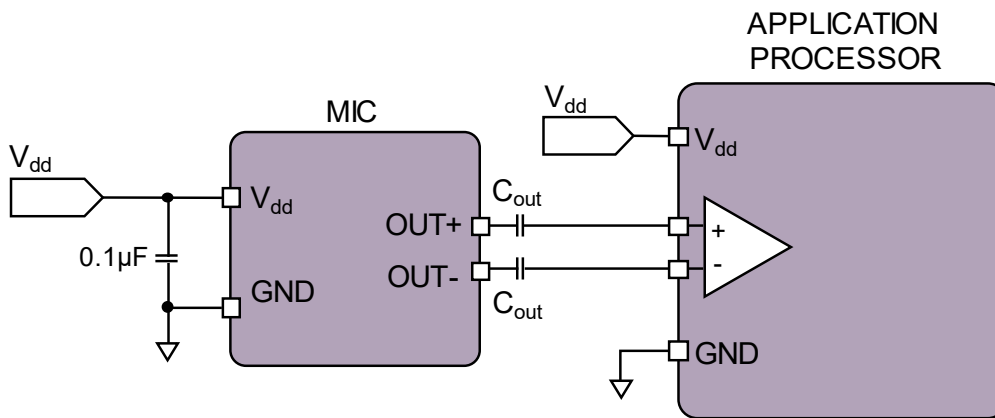

Figure 6.2: Typical differential application circuit

7. Specifications

Test conditions throughout full datasheet unless otherwise indicated: 25 °C, 55 ± 20% R.H., $V_{dd} = 1.8\text{ V}$, differential, 3 m away, 10 mm acoustic path length¹, no load, PCB port facing toward the loudspeaker (0° rotation).

7.1 Acoustic and Electrical Specifications

Parameter	Symbol	Condition	Min.	Typ.	Max.	Unit
Pickup Pattern			Dipole (figure-8)			
Polarity		Increasing sound pressure at lid port	Increasing output voltage			
		Increasing sound pressure at PCB port	Decreasing output voltage			
Average Directivity Index ²		Integrated from 20 Hz to 20 kHz	4.8			dB
Null Angle			90, 270			°
Supply Voltage	V_{dd}	Standard Mode	1.6	1.8	2.0	V
		High-AOP Mode	2.2	2.8	3.6	
Supply Current	I_{dd}	$V_{dd} = 1.8\text{ V}$	115			µA
		$V_{dd} = 2.8\text{ V}$	160			
Sensitivity	S	94 dB SPL, 1 kHz, Single-Ended	-36	-35	-34	dBV/Pa
		94 dB SPL, 1 kHz, Differential	-30	-29	-28	
Noise Floor		Single-Ended	-92.5			dBV(A)
		Differential	-86.5			
Signal to Noise Ratio ³	SNR	20 Hz to 20 kHz, 94 dB SPL, Single-Ended	63.5			dB(A)
		20 Hz to 20 kHz, 94 dB SPL, Differential	63.0			
Total Harmonic Distortion ⁴	THD	94dB SPL, 1kHz	<0.1			%
		1% THD, 1 kHz	116			
Acoustic Overload Point	AOP	10% THD, 1 kHz, Standard Mode	131			dB SPL
		10% THD, 1 kHz, High-AOP Mode	134			
Resonant Frequency	Fres		4.3			kHz
Phase Response		75 Hz	-7			°
		1 kHz	-38			
		3 kHz	-109			
Group Delay		250 Hz	91			µs
		600 Hz	95			
		1 kHz	98			
		4 kHz	82			
Power Supply Rejection Ratio	PSRR	200 mVpp sine wave on V_{dd} at 1 kHz, Single-Ended	64			dB
		200 mVpp sine wave on V_{dd} at 1 kHz, Differential	58			
Power Supply Rejection	PSR+N	200mVpp 7/8 duty cycle rectangular waveform @ 217 Hz on V_{dd} , A-weighted, BW = 20 kHz, Single-Ended	-84			dBV(A)
		200mVpp 7/8 duty cycle rectangular waveform @ 217 Hz on V_{dd} , A-weighted, BW = 20 kHz, Differential	-84			
DC Voltage Output		$V_{dd} = 1.8\text{ V}$	0.836			V
		$V_{dd} = 2.8\text{ V}$	1.336			
DC Offset		OUT+ to OUT-	±10			mV
Output Impedance	Z_{out}		100			Ω
Startup Time		Sensitivity within 1 dB of final value, outputs AC coupled	15			ms

Table 7.1: Acoustic and electrical specifications

¹ The acoustic path length is the minimum distance a soundwave must travel between the ports of the microphone. See [Acoustic Path Length Definition](#) for details.

² The directivity index is a measure of directionality based on the ratio of direct sound to diffuse sound captured. See [Directivity Index Calculation](#) for details.

³ A directional microphone has a non-flat frequency response, as such the SNR must be calculated for the entire frequency range. See [SNR Calculation](#) for details.

⁴ To calculate the THD of a microphone with a non-flat frequency response, the frequency response must first be equalized. See [THD Calculation](#) for details.

7.2 Absolute Maximum Ratings

Stresses at or above the Absolute Maximum Ratings could permanently damage the devices.

Parameter	Absolute Maximum Rating	Unit
V _{dd} to GND	5.0	V
Input Current	±5	mA
Storage Temperature	-40 to 100	°C
Operating Temperature	-40 to 85	°C

Table 7.2: Absolute maximum ratings

7.3 Specification Calculation Details

Acoustic Path Length Definition

The acoustic path length is the minimum distance a sound wave must travel around the microphone package between the two ports. The microphone is designed to perform best with path lengths found in end-products, which are typically 10 mm or greater. All specifications are measured with a standard 10 mm path length, the minimum recommended path length when integrating the device.

Directivity Index and Average Directivity Index Calculation

The **directivity index** (DI) measures the ratio of the microphone output for a sound positioned directly in front of the microphone ($\theta = 0^\circ$) versus sound with the same amount of total acoustic power coming from all directions equally. The directivity index at each frequency is calculated with the equation below.

$$DI = 10 \log_{10} \left(4 \frac{\text{amplitude}(\theta = 0)^2 \left[\frac{V^2}{Pa^2} \right]}{\int_0^{2\pi} \text{amplitude}(\theta)^2 \left[\frac{V^2}{Pa^2} \right] |\sin \theta| d\theta} \right)$$

Equation 7.1: Directivity Index

The average directivity index is calculated by logarithmically weighting the directionality index at each frequency and then taking the average of these weighted values from 20 Hz to 20 kHz.

SNR Calculation

The SNR of a directional microphone with a non-flat frequency response must be calculated differently than the typical method used for omnidirectional microphones that have a flat frequency response. Instead of only using the 1 kHz sensitivity, the electrical noise of the microphone at each frequency (units of V^2/Hz) must be divided by the corresponding sensitivity squared at each frequency (units of V^2/Pa^2) to obtain the input referred acoustic noise at each frequency (units of Pa^2/Hz). Then, the acoustic noise is A-weighted by multiplying it by the A-weighting factor (A_w) and this A-weighted acoustic noise is integrated over the full audio bandwidth and converted to an equivalent sound pressure level (dBA SPL) by dividing by the reference pressure ($P_{ref}=20 \mu Pa$). Finally, the SNR is calculated by subtracting the integrated input referred noise from 94 dB SPL. The equation for the calculation is shown below.

$$SNR = 94 - 20 \log_{10} \left(\frac{1}{P_{ref}^2 [Pa^2]} \int_{20Hz}^{20kHz} \frac{\text{noise} \left[\frac{V^2}{Hz} \right]}{\text{sensitivity} \left[\frac{V^2}{Pa^2} \right]} A_w df [Hz] \right)$$

Equation 7.2: Full-spectrum SNR calculation

THD Calculation

THD is calculated by playing an acoustic sine wave at a specific sound pressure level and frequency and dividing the sum of the powers of the harmonic components of the captured signal by the power of the fundamental frequency. To calculate the THD of a microphone with a non-flat frequency response, the response must first be equalized to equally weigh the fundamental frequency and its respective harmonics.

For more information on these calculations, refer to the app note: [AN-110: Attributes of Soundskrit Directional Microphones](#).

7.4 Performance Curves

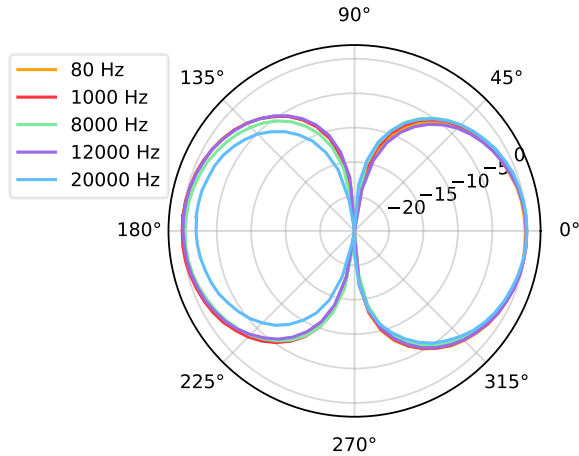

Figure 7.1: Pickup pattern vs. frequency

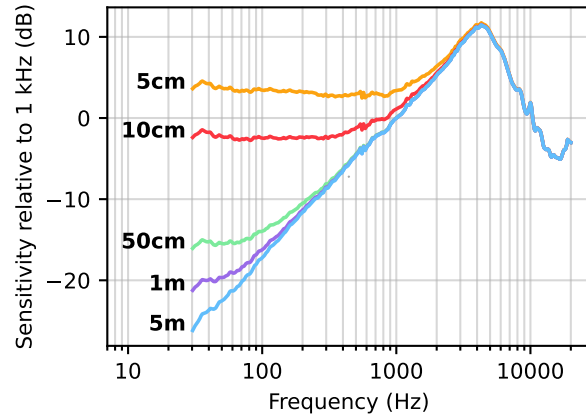

Figure 7.2: Typical magnitude response⁵

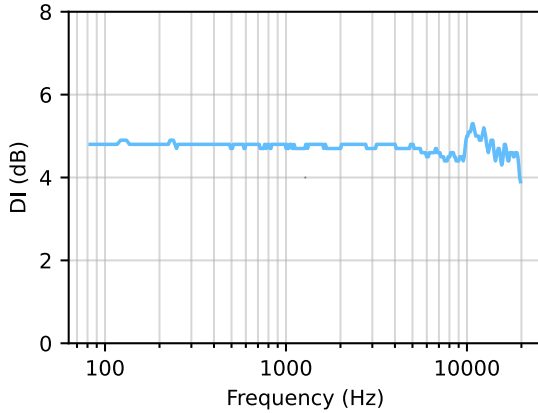

Figure 7.3: Directivity index vs frequency

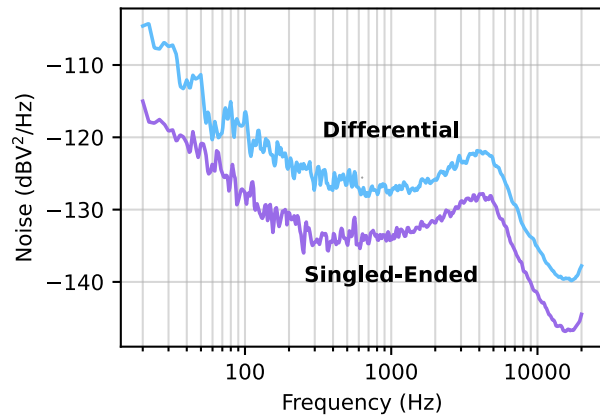

Figure 7.4: Typical noise floor

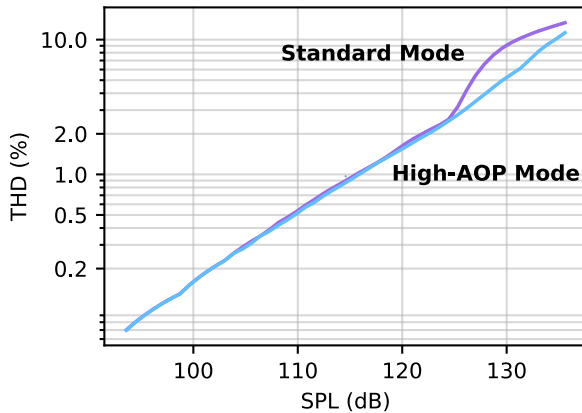

Figure 7.5: Typical THD (1 kHz) vs SPL

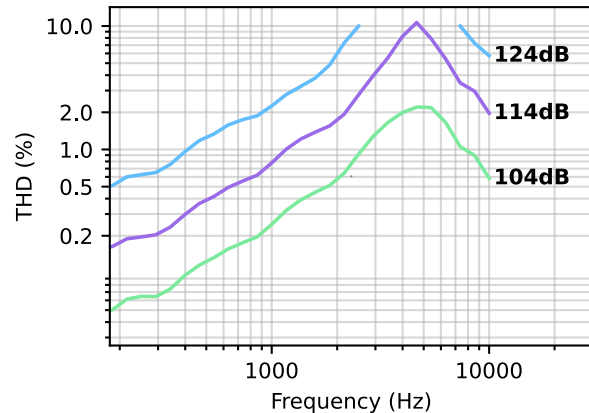

Figure 7.6: THD vs frequency

⁵ The increased bass response at close distances is known as the 'Proximity Effect.' See [AN-110](#) for details.

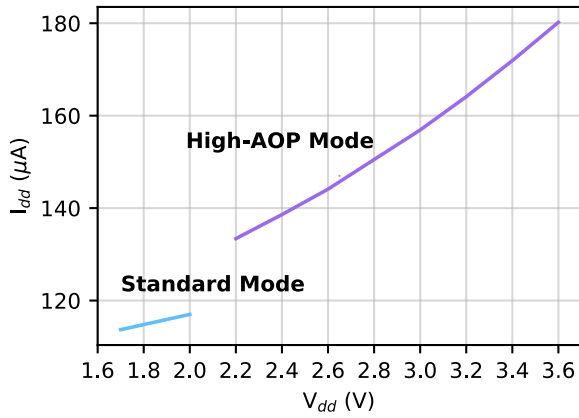

Figure 7.7: Supply current vs input voltage

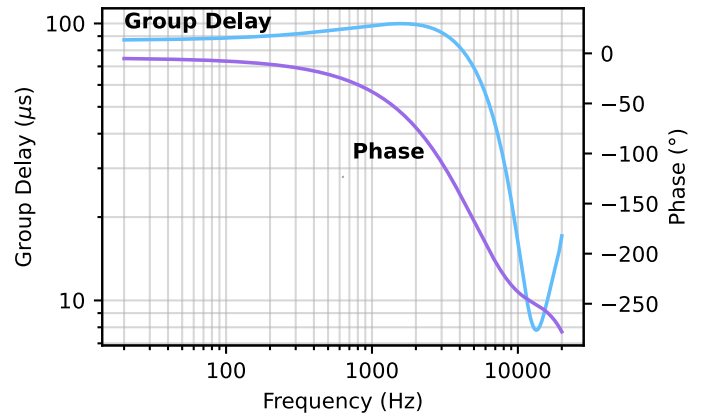

Figure 7.8: Typical phase and group delay

8. Mechanical, Packaging, and Manufacturing Information

8.1 Mechanical Dimensions and Product Marking

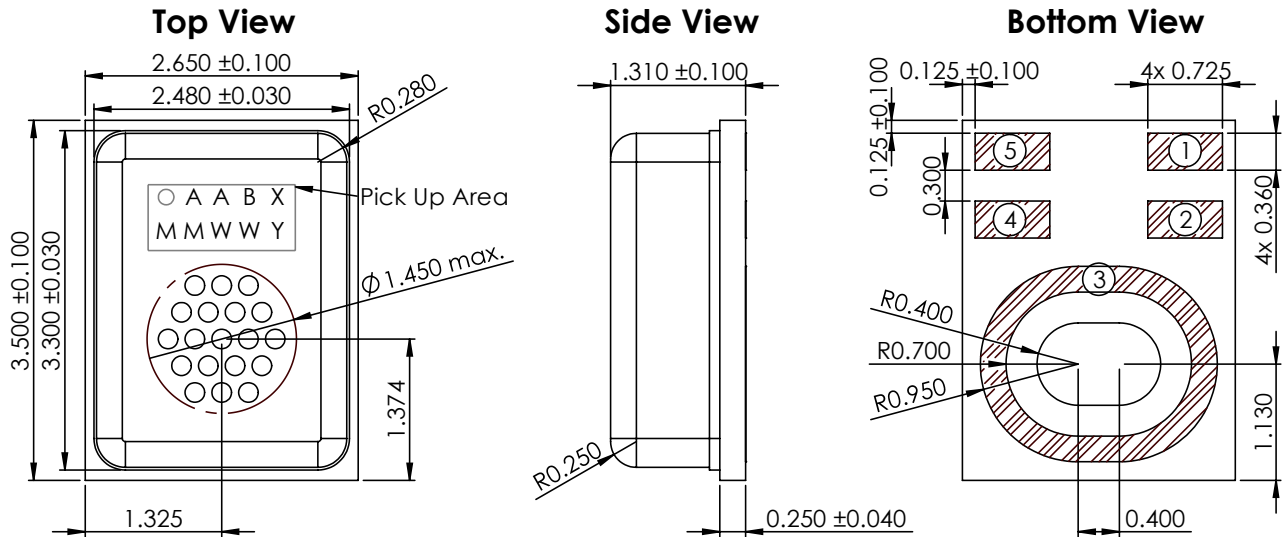

Figure 8.1: Mechanical drawings (mm)

Table 8.1: Mechanical specifications

Item	Dimensions (mm)
Length	3.500 ± 0.100
Width	2.650 ± 0.100
Height	1.310 ± 0.100
Lid Port Array OD	1.450 max
Bottom Acoustic Port	1.200 x 0.800 ± 0.050

Table 8.2: Pinout

Pin #	Pin Name	Description
1	OUT+	Non-Inverted Output Signal
2	OUT-	Inverted Output Signal
3, 4	GND	Ground
5	V _{dd}	Power Supply

Table 8.3: Product marking

Marking	Description
AA	Model Code: SKR0AA0
B	0: Final Production
XMM	Internal Codes
WW	Week WW of the year
Y	Year 202Y

8.2 Land Pattern and Solder Stencil

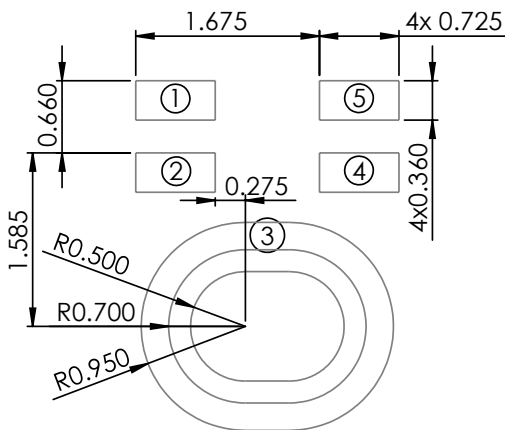

Figure 8.2 Example land pattern (mm)

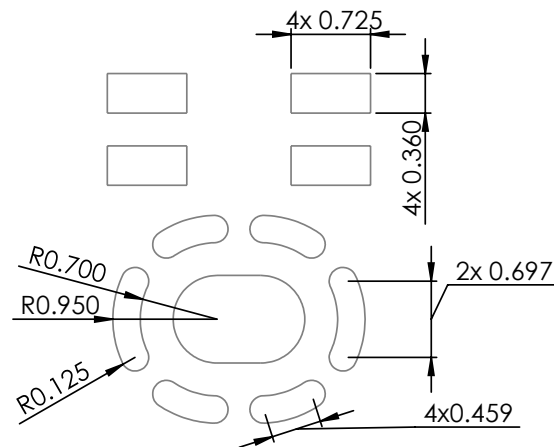

Figure 8.3 Example solder stencil pattern (mm)

8.3 CAD Models

The CAD model and KiCAD layout and footprint are available here: [STEP File and KiCAD](#).

8.4 Packaging and Ordering Information

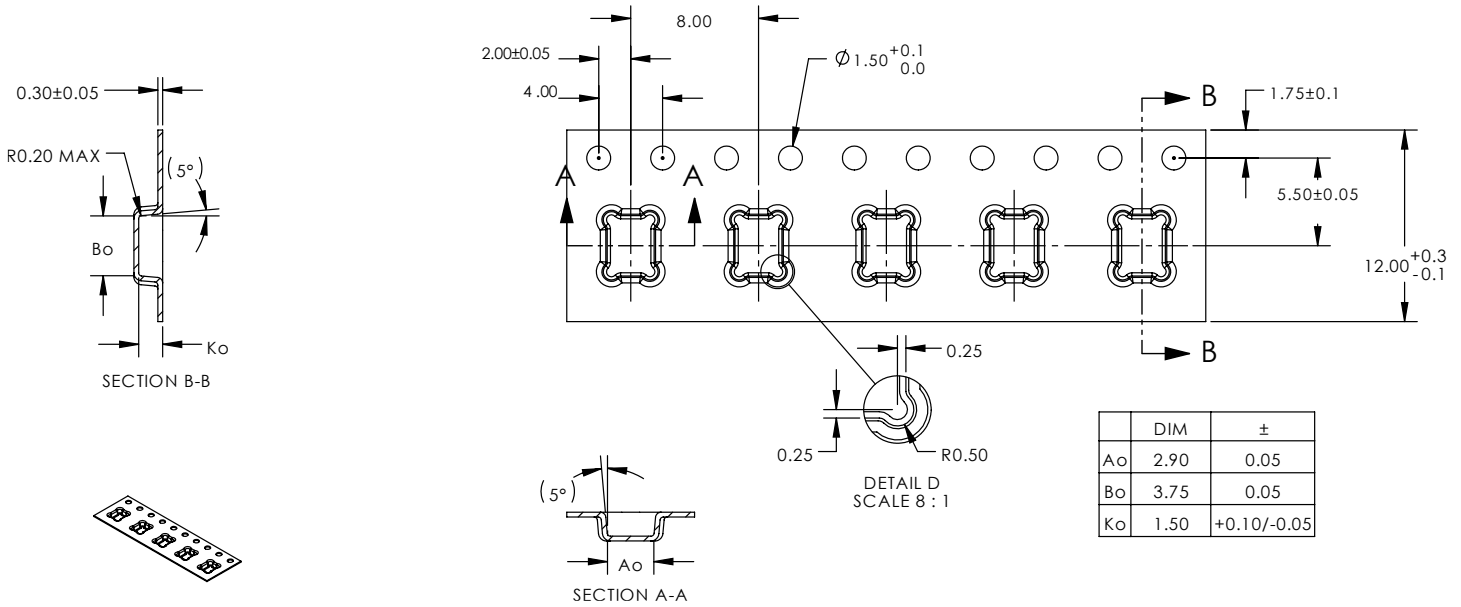

Figure 8.3 Reel dimensions (mm)

Table 8.3: Ordering Information

Model Number	Reel Diameter	Quantity per Reel
SKR0400-7	7"	1300
SKR0400-13	13"	5000

Table 8.4: Packaging Information

Component	Surface Resistance (Ω)
Reel	10 ⁵ to 10 ¹²
Carrier Tape	10 ⁵ to 10 ¹¹
Cover Tape	10 ⁵ to 10 ¹²

8.5 Reflow Profile and Handling Instructions

Figure 8.5 shows the recommended reflow profile for soldering the microphone. The reflow profile is based on the standard J-STD-020D. The microphone has a moisture sensitivity level (MSL) of Class 1.

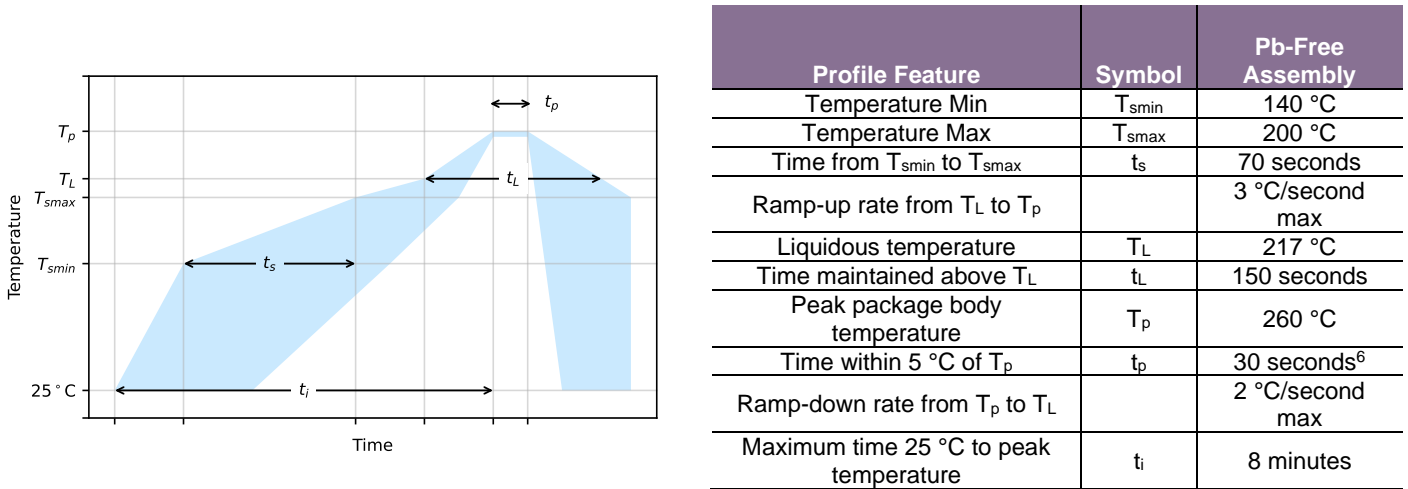

Figure 8.5: Reflow profile

The microphone is packaged with a layer of reflow-compatible Kapton tape covering the lid port. This tape protects the microphone during reflow and assembly and should only be removed at the latest stage possible in the assembly process. Do not remove the Kapton tape prior to soldering the microphone or nearby components. To remove the Kapton tape, use tweezers to catch the edge of the tape and peel the tape off.

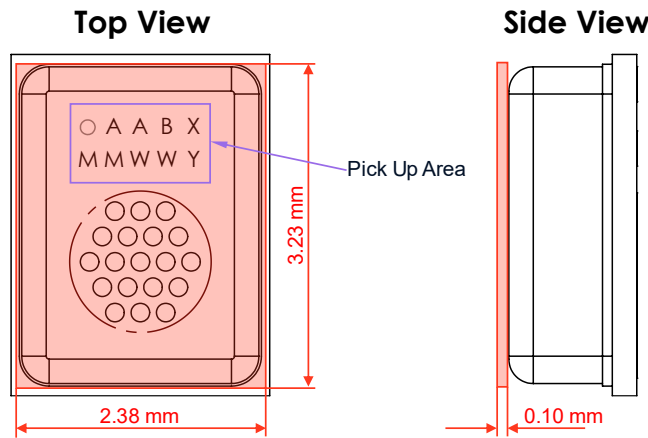

Figure 8.6: Mechanical drawing with protective tape

The MEMS microphones should be handled using industry standard pick and place equipment or appropriate manual handling procedures. To minimize device damage, please carefully follow the guidelines below:

- Use the pick-up area shown in Figure 8.6.
- Do not apply a vacuum or high pressure over the top or bottom acoustic port hole.
- Do not apply air blow and ultrasonic cleaning procedures over the acoustic port hole.
- Do not board wash or clean after the reflow process.
- Do not expose the acoustic port hole to harsh chemicals.
- Do not directly expose the acoustic port hole to solder fumes or vapor phase soldering.
- Do not apply a vacuum when packing parts in sealed bags at a suction flow rate faster than 0.85 CFM.

⁶ Tolerance for peak profile temperature (T_p) is defined as a supplier minimum and a user maximum.

9. Reliability Specifications

The microphone sensitivity must deviate by no more than 1 dB from the initial value after 3 reflow cycles for the reflow test and no more than 3 dB for the other tests.

Test	Test Condition	Standard
ESD-CDM	3 discharges of ± 500 V with direct contact to I/O pins	JEDEC-JS002
ESD-HBM	3 discharges of ± 2 kV with direct contact to I/O pins	JEDEC-JS001
ESD-LID/GND	3 discharges of ± 8 kV with direct contact to lid while unit is under bias	IEC-61000-4-2
Free Fall	Microphone put in a 150g block, drop from 1.5m onto concrete floor, 4 drops for each surface and corner, total 40 drops	IEC 60068-2-32
High Temperature Bias	+125 °C for 1,000 hours under bias	JESD22 A-108F
High Temperature Storage	+125 °C for 1,000 hours	JESD22 A-103E
Low Temperature Bias	-40 °C for 1,000 hours under bias	JESD22 A-108F
Low Temperature Storage	-40 °C for 1,000 hours	JESD22-A119A
Mechanical Shock	5 shocks of 10,000 g / 0.1 msec in each direction of $\pm x$, $\pm y$, $\pm z$, 30 shocks in total	IEC 60068-2-27
Reflow	3 reflow cycles with +260 °C peak temperature	IPC-JEDEC J-STD-020E
Temperature Humidity Bias	+85 °C/85% R.H. for 1,000 hours under bias	JESD22-A101D
Thermal Shock	100 cycles, air-to-air, -40 °C to +125 °C, 15 minutes soak	JESD22.A104E
Tumble	Microphone put in a 150g block, drop from 1m onto steel base, rotation speed 10-11 times/min, 300 drops	IEC 60068-2-32
Vibration	4 cycles of 4 minutes each in each x, y, z axis from 20 Hz to 2000 Hz with peak acceleration of 20 G	MIL-STD-883E-2007-2-A

Table 9.1: Reliability specifications

10. Device and Documentation Support

Supporting application notes can be found on our [application notes page](#).

11. Revision History

Revision Label	Revision Date	Sections Revised
-	January 2023	Official release
A	April 2023	Application circuit and recommendations
B	December 2023	Added product marking and handling instructions
C	June 2024	Updated to reflect new package design, Updated Section 8 and 9
D	August 2024	Updated SKR0400-7 reel size to 1300 and land pattern drawing



Soundskrit developed the first high-performance directional MEMS microphone on the market, leveraging years of research in bio-inspired MEMS based on how spiders and other insects in nature hear. In combination with Soundskrit's in-house audio processing algorithms, directional microphones can be used to capture and isolate any sound in an environment with a fraction of the size, power, and computation of traditional omnidirectional-based microphone arrays.

Soundskrit was founded in 2019 and is headquartered in Montreal, Quebec with an R&D facility in Ann Arbor, Michigan.

