



13.2 x 13.2 x 5.6mm  
Metal DIP Package

## Features

- Field Programmable with the [PG-3200](#) oscillator programming instrument within seconds.
- Can be programmed twice (single Frequency) or one time as Dual frequency
- CMOS Output (will interface with TTL devices)
- 3.3V or 5.0V nominal Supply Voltage
- Size: Half DIP
- Enable/Disable Function (optional Standby function) for single frequency program only

## Applications

Driving A/Ds, D/As, FPGAs  
Digital Video  
Ethernet, GbE  
Medical  
Storage Area Networking  
COTS  
Broad Band Access  
SONET/ SDH/ DWDM  
Test & Measurement

## Electrical Characteristics

Parameter	Min	Typ	Max	Unit	Condition
Programmable Frequency Range	1	-	133	MHz	(3.3V : 1-100MHz)
Frequency Stability <sup>2</sup>	±25	-	±100	ppm	For all supply voltages, load changes, aging for 1 year at 25°C ± 2°C, shock, vibration and temperatures.
Operating Temperature Range options <sup>2</sup>	-20 -40	- -	+70 +85	°C	
Supply Voltage <sup>1,2</sup> V <sub>DD</sub>	2.97	-	5.5	V	See Part Number options on page 2
Supply Current I <sub>DD</sub> (No Load)	-	-	45 25	mA	V <sub>DD</sub> = 5.0V V <sub>DD</sub> = 3.3V
Output Type	CMOS				Cload = 50pF max, V <sub>DD</sub> = 4.5~5.5V, ≤ 66MHz Cload = 25pF max, V <sub>DD</sub> = 4.5~5.5V, > 66MHz Cload = 30pF max, V <sub>DD</sub> = 2.97~3.63V, ≤ 40MHz Cload = 15pF max, V <sub>DD</sub> = 2.97~3.63V, > 40MHz
	TTL				Cload = 50pF max; V <sub>DD</sub> = 4.5~5.5V, ≤ 40MHz
Duty Cycle	-	-	-	%	See Page 2
Output V <sub>OH</sub> (TTL Level) (CMOS Level)	2.4	-	-	V	V <sub>DD</sub> = 4.5~5.5V
	V <sub>DD</sub> - 0.4			V	All voltages
Output V <sub>OL</sub>	-	-	0.4	V	See Load Circuit and waveform page
Output T <sub>RISE</sub> and T <sub>FALL</sub>	-	-	-	ns	See page 2
Startup Time	-	-	2	ms	Time for output to reach specified frequency
V <sub>DISABLE</sub>	-	-	0.8 0.2V <sub>DD</sub>	V	V <sub>DD</sub> = 4.5~5.5V V <sub>DD</sub> = 2.97~3.63V
V <sub>ENABLE</sub>	2.0 0.7V <sub>DD</sub>	-			V <sub>DD</sub> = 4.5~5.5V V <sub>DD</sub> = 2.97~3.63V
Enable Time	-	-	2	ms	
Disable Time - Pin 1 low to Output Hi-Z	-	T/2	T+10	ns	T = Frequency Period
Disable Current	-	-	-	mA	Enable/Disable: Pad 1 low, output disabled; See above Supply Current
	-	0.4	-		Standby option: Pad 1 low, output disabled, oscillator shutdown
RMS Period Jitter	-	40 30	50 40	ps	≤ 33MHz > 33MHz
Period Jitter, Pk-Pk		100 75	250 175	ps	>1,000,000 samples ≤ 33MHz > 33MHz
Storage Temperature Range	-55	-	+125	°C	

Notes: Specifications with Pad 1 E/D open circuit

<sup>1</sup> Place an appropriate power supply bypass capacitor next to device for correct operation

<sup>2</sup> Specified by part number

**Duty Cycle**

Parameter	Min	Typ	Max	Unit	
TTL @ 1.4V level; V <sub>DD</sub> = 4.5~5.5V	45 45 40 40		55 55 60 60	%	Fo ≤ 50 MHz, CL ≤ 50pF 50 MHz < Fo ≤ 66MHz; CL ≤ 15pF 66 MHz < Fo ≤ 125MHz, CL ≤ 25pF 125 MHz < Fo ≤ 133MHz, CL ≤ 15pF
CMOS @ 0.5V <sub>DD</sub> level; V <sub>DD</sub> = 4.5~5.5V	45 40 40		55 60 60	%	Fo ≤ 66 MHz, CL ≤ 25pF 66 MHz < Fo ≤ 125MHz; CL ≤ 25pF 125 MHz < Fo ≤ 133MHz, CL ≤ 15pF
CMOS @ 0.5V <sub>DD</sub> level; V <sub>DD</sub> = 2.97~3.63V	45 40		55 60	%	Fo ≤ 40 MHz, CL ≤ 30pF 40 MHz < Fo ≤ 100MHz; CL ≤ 15pF

**Rise/Fall Time**

Parameter	Min	Typ	Max	Unit	
Rise/Fall Time			1.8 1.2 0.9  3.4 4.0 2.4	ns	0.8V~2.0V, V <sub>DD</sub> = 4.5~5.5V, CL=50pF 0.8V~2.0V, V <sub>DD</sub> = 4.5~5.5V, CL=25pF 0.8V~2.0V, V <sub>DD</sub> = 4.5~5.5V, CL=15pF  0.2V <sub>DD</sub> ~0.8V <sub>DD</sub> , V <sub>DD</sub> = 4.5~5.5V, CL=50pF 0.2V <sub>DD</sub> ~0.8V <sub>DD</sub> , V <sub>DD</sub> = 2.97~3.63V, CL=30pF 0.2V <sub>DD</sub> ~0.8V <sub>DD</sub> , V <sub>DD</sub> = 2.97~3.63V, CL=15pF

**Part Number Example: CPPX4-A7BP-XX.XXXNP**

Series Model	Package Size		Operating Temperature Range	Frequency Stability (ppm)			
CPPX	4	-	A7	BR	-	XX.XXX	NP or NC
	4 = Half DIP		A5 = -20 to +70°C A7 = -40 to +85°C	BC = ±20 BR = ±25 BP = ±50 B6 = ±100			

### Mechanical Dimensions (mm)

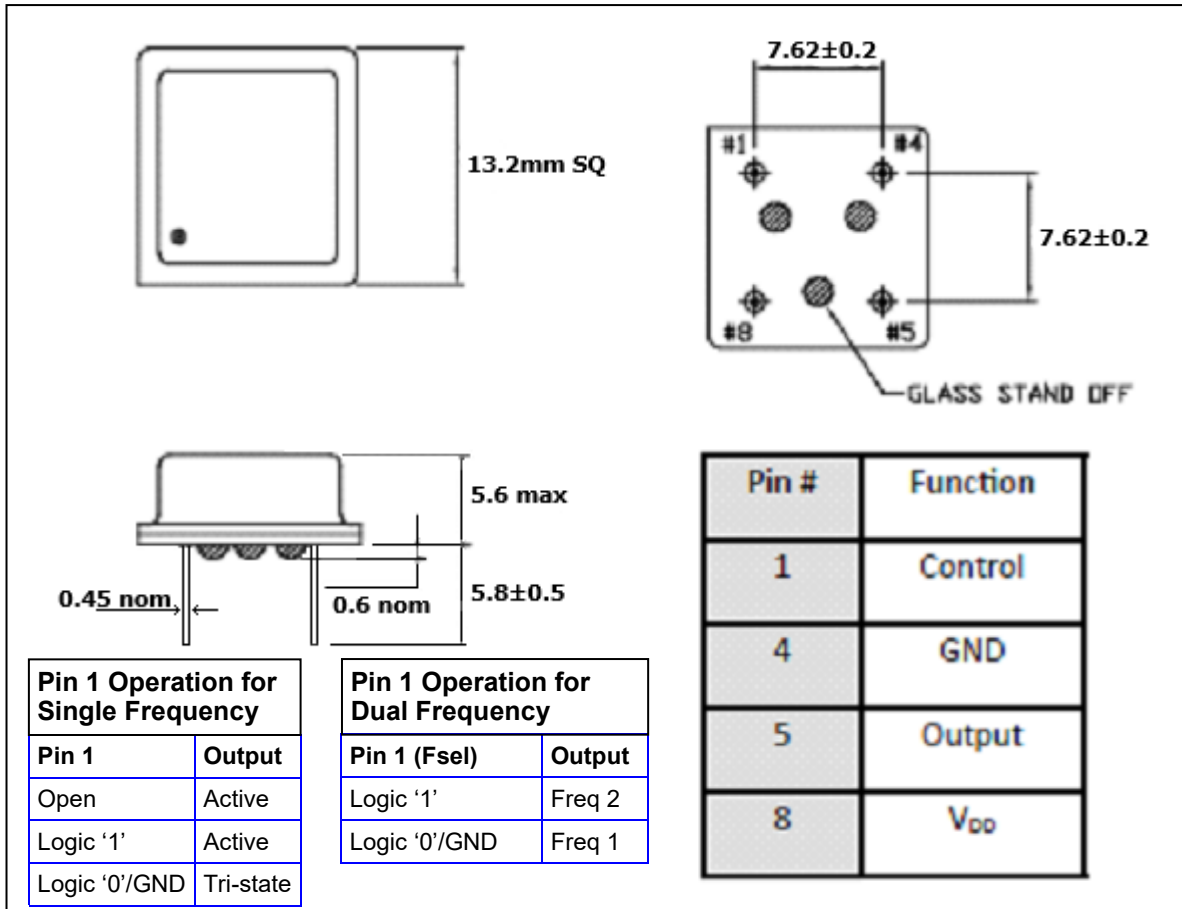

Pin 1 Operation for Single Frequency	
Pin 1	Output
Open	Active
Logic '1'	Active
Logic '0'/GND	Tri-state

Pin 1 Operation for Dual Frequency	
Pin 1 (Fsel)	Output
Logic '1'	Freq 2
Logic '0'/GND	Freq 1

Termination coating: SnAgCu (SAC305): 2 ~ 7µm

Cardinal Components Inc. certifies this device is in accordance with the RoHS and REACH directives.

Cardinal Components guarantees the device does not contain the following: Cadmium, Hexavalent Chromium, Lead, Mercury, PBB's, PBDE's  
 Weight of the Device: 2.2 grams  
 Moisture Sensitivity Level: 1 As defined in J-STD-020D  
 Second Level Interconnect code: e1

For Optimum Jitter Performance, Cardinal recommends:

- A ground plane under the device
- Do not route large transient signals (both current and voltage) under the device
- Do not place near a large magnetic field such as a high frequency switching power supply
- Do not place near piezoelectric buzzers or mechanical fans

## Electrical Test / Load Circuit

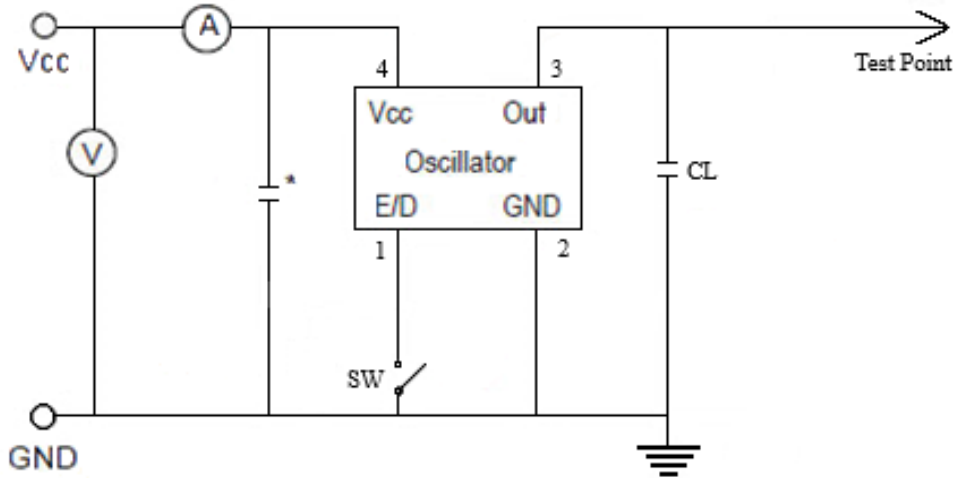

Notes:  
 CL: 15pF Includes the input capacitance of oscilloscope  
 \* 0.01~0.1 $\mu$ F external by-pass filter is recommended

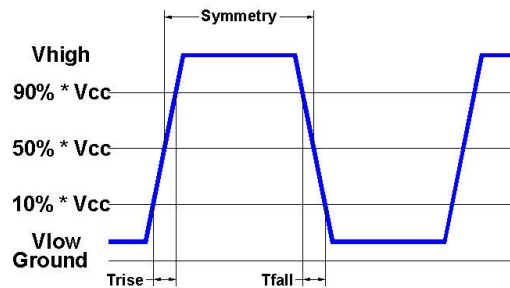

## Environmental / ESD Ratings

Reliability: Environmental

Parameter	Condition
Mechanical Shock	MIL-STD-883, Method 2002, Condition B
Vibration	MIL-STD-883, Method 2007, Condition A
Solderability	IPC J-STD-002
Thermal Cycle	MIL-STD-883 Method 1010, Condition B

ESD Rating

Model	Min. Voltage	Condition
Human Body Model	2000V	MIL-STD-883 3015.7
Machine Model	200V	EIAJ ED-4701/304

Absolute Maximum Ratings

Parameter	Unit
V <sub>CC</sub> Supply Voltage	-0.5V to +7.0V
V <sub>i</sub> Input Voltage	-0.5V to V <sub>CC</sub> + 0.5V
V <sub>o</sub> Output Voltage	-0.5V to V <sub>CC</sub> + 0.5V

### Thermal Characteristics:

The maximum die or junction temperature is 100°C

**Important Notice**

Cardinal Components (CC) reserves the right to make corrections, improvements, modifications and other changes to this product at anytime. CC reserves the right to discontinue any product or service without notice. Customers are responsible for obtaining the latest relevant information before placing orders and should verify that such information is current and complete. All products are sold subject to CC's terms and conditions of sale supplied at the time of order acknowledgment.

CC warrants performance of this product to the specifications applicable at the time of sale in accordance with CC's limited warranty. Testing and other quality control techniques are used to the extent CC deems necessary to support this warranty. Except where mandated by specific contractual documents, testing of all parameters of each product is not necessarily performed.

CC assumes no liability for application assistance or customer product design. Customers are responsible for their products and applications using CC components. To minimize the risks associated with the customer products and applications, customers should provide adequate design and operating safeguards.

CC products are not designed, intended, authorized or warranted to be suitable for use in life support applications, weapons, weapon systems or space applications, devices or systems or other critical applications that may involve potential risks of death, personal injury or severe property or environmental damage. Inclusion of CC products in such applications is understood to be fully at the risk of the customer. Use of CC products in such applications requires the written approval of an appropriate CC officer. Questions concerning potential risk applications should be directed to CC.

CC does not warrant or represent that any license, either express or implied, is granted under any CC patent right, copyright, artwork or other intellectual property right relating to any combination, machine or process which CC product or services are used. Information published by CC regarding third-party products or services does not constitute a license from CC to use such products or services or a warranty or endorsement thereof. Use of such information may require a license from a third party under the patents or other intellectual property of the third party, or a license from CC under the patents or other intellectual property of CC.

Reproduction of information in CC data sheets or web site is permissible only if the reproduction is without alteration and is accompanied by associated warranties, conditions, limitations and notices. Reproduction of this information with alteration is an unfair and deceptive business practice. CC is not responsible or liable for such altered documents.

Resale of CC products or services with statements different from or beyond the parameters stated by CC for that product or service voids all express and implied warranties for the associated CC product or service and is an unfair or deceptive business practice. CC is not responsible for any such statements.

**Contacting Cardinal Components**

Cardinal Components  
19013 36th Ave. West  
Lynnwood, WA 98036-5761  
U.S.A.

Tel: 973-785-1333  
Fax: 425.776.2760  
email: [sales@cardinalxtal.com](mailto:sales@cardinalxtal.com)  
URL: [www.cardinalxtal.com](http://www.cardinalxtal.com)