



Accurate Kinetic Energy
No.11-3 Jianguo Rd., Tanzi Dist., 42760 Taiwan

All dimensions are millimeters.

CAD:	TCR
Review:	EG
Appr:	JL
Page:	1/4
Date:	February 5,2025

Specification Title:

**Clock Oscillator
Automotive Grade
2.0 x 1.6 millimeter Surface Mount
General Product Specification**

**AEC-Q200 Qualified
IATF 16949 Certified**

Part Number:

S1 Auto Series

Electrical Specifications:

Frequency Range		10.000~40.000	10.000~50.000	10.000~50.000	2.000 ~ 60.000	2.000 ~ 60.000	2.000 ~ 60.000	2.000 ~ 60.000	MHz
Frequency Stability		±25 ~ ±100							ppm
Aging per Year		±3							ppm Max.
Operating Temperature Range	Standard	-40 ~ +85							°C
	Option	-40 ~ +105							
	Option	-40 ~ +125							
Storage Temperature Range		-55 ~ +125							
Supply Voltage		0.9 ± 5%	1.2 ± 5%	1.5 ± 5%	1.8 ± 10%	2.5 ± 10%	3.3 ± 10%	1.62 ~ 3.63	VDD
Input Current	2.000 to 9.999MHz	-	-	-	3	4	5	5	mA Max.
	10.000 to 19.999MHz	1.5	2.5	3.5	4	5	6	6	
	20.000 to 31.999MHz	1.5	2.5	3.5	5	6	7	7	
	32.000 to 50.000MHz	2	3.5	4.5	6	7	8	8	
Output Voltage	Logic High (Voh)	90%							VDD Min.
	Logic Low (Vol)	10%							VDD Max.
Output Symmetry (Duty Cycle)	Standard	40 ~ 60 (at 50% VDD)							%
	Tight	45 ~ 55 (at 50% VDD)							
Output Level		CMOS							
Output Load		15							pF Max.
Rise and Fall Time	2.000 to 9.999MHz	-	-	-	6	5	5	6	ns Max.
	10.000 to 19.999MHz	15	12	10	6	5	5	6	
	20.000 to 31.999MHz	15	12	10	5	5	5	5	
	32.000 to 50.000MHz	15	12	10	5	5	5	5	
Phase Jitter RMS (12 KHz to 20 MHz)		1							ps Max.
Enable-Disable Function		Tri-State							
Start Up Time		5							ms Max.

Temperature stability is Inclusive of all conditions:

Calibration Tolerance at +25°C, frequency stability over the operating temperature range, supply voltage change, output load change, shock, vibration, and 1st year aging at +25°C.

RoHS Compliant Pb - Lead Free AEC-Q200 Qualified IATF 16949 Certified	Ltr	Revisions	Date	Appr

Mechanical Outline and Solder Pad Layout:

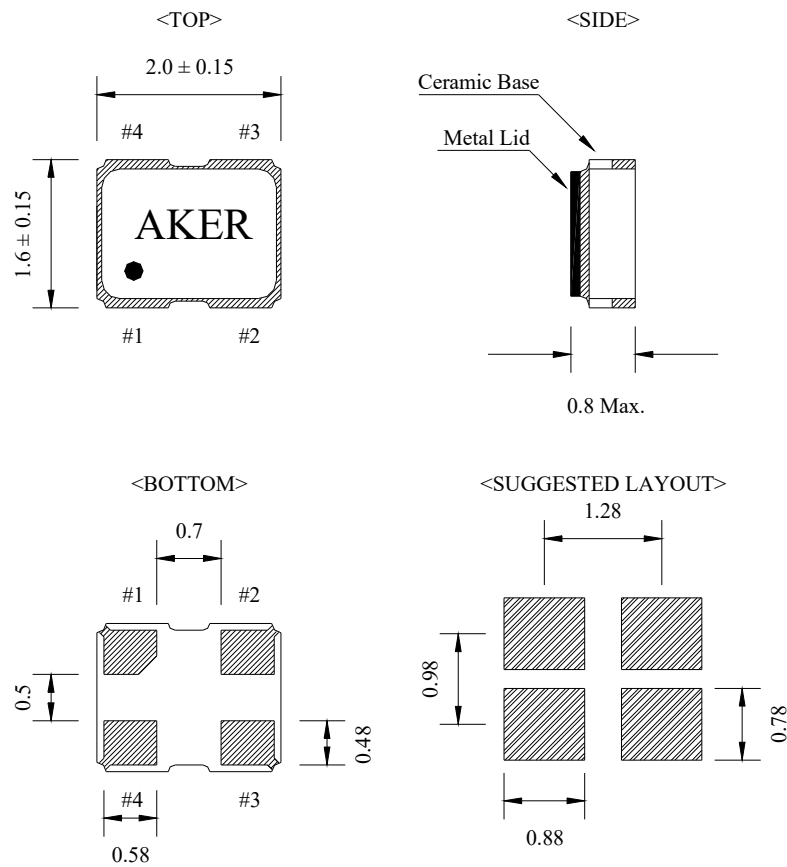

Pin Connection	
PIN No.	Connection
#1	Enable/Disable
#2	GND
#3	Output
#4	VDD

Enable/Disable Function	
PIN #1	PIN #3
HIGH or OPEN	Operating
LOW	High Impedance

Package is Seam Sealed Ceramic-Metal.

Terminator Pads are Ni/Au.

Dimensions are millimeters.

Carrier Tape Dimensions:

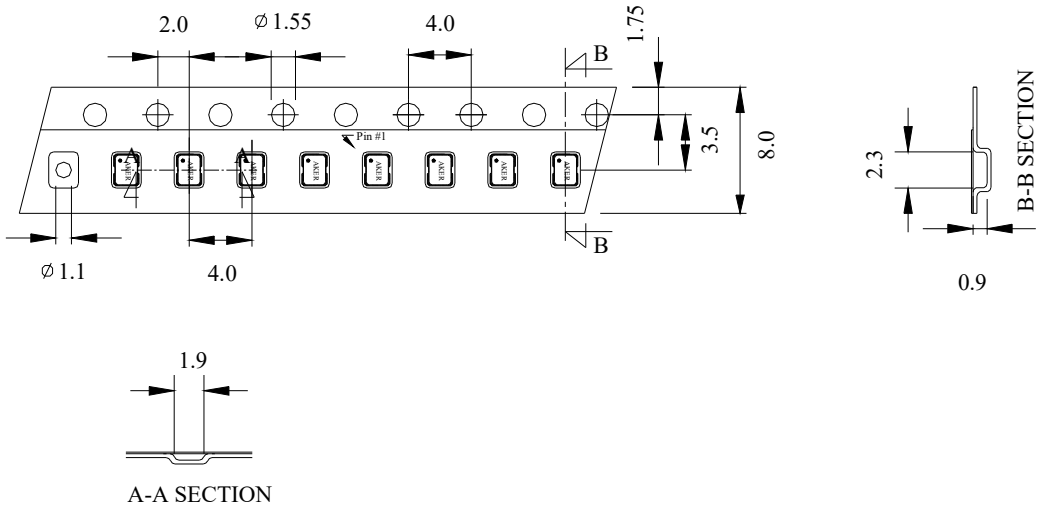

Dimensions are millimeters.

Solder Reflow Characteristics:

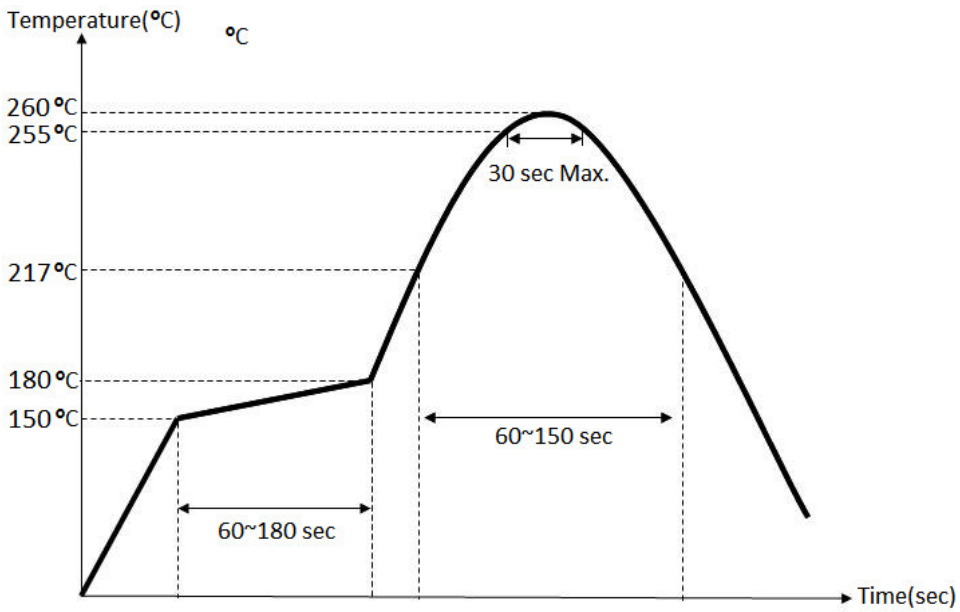

How to build a Part Number:

Series	S	Parameter
Package	1	2.0 x 1.6 mm
Supply Voltage	33	+3.3 VDD ± 10%
	25	+2.5 VDD ± 10%
	18	+1.8 VDD ± 10%
	15	+1.5 VDD ± 5%
	12	+1.2 VDD ± 5%
	09	+0.9 VDD ± 5%
	M	+1.62 ~ +3.63 VDD
Temperature Stability	10	±100 ppm
	05	±50 ppm
	03	±30 ppm
	025	±25 ppm
Duty Cycle	See Notes	40%~60%
	T	45%~55%
Frequency	2.000~60.000	MHz
AECQ-200	A	Automotive
Temperature Range	X	-40 ~ +85 °C
	X1	-40 ~ +125 °C
	X2	-40 ~ +105 °C
Packaging	M	250pcs Reel
	R	1000pcs Reel
	R3	3000pcs Reel

Part Number Example:

S13305T-50.000-A-X-R

S1: 2.0 x 1.6 mm SMD Package

33: +3.3±10% VDD Supply Voltage

05: ±50 ppm Temperature Stability

T: 45%~55% Tight Symmetry

50.000 MHz Nominal Frequency

A: Automotive Grade

X: -40 ~ + 85°C Temperature Range

R: Tape and Reel Packaging - 1000pcs Reel

Notes:

- 1- Standard Duty Cycle and Temperature Range do not need to be included in Part Number description.
- 2- Product is shipped in Tape and Reel configuration.
- 3- Quantities less than 250pcs are shipped in tape only.
- 4- Specification subject to change without notice.