

## Features

### HIGH CURRENT CARRY AND HIGH VOLTAGE

Inert gas filled arc chamber suitable for high voltage switching

### COMPACT STRUCTURE, LOW NOISE

Small, low-profile design with low noise while carrying or switching loads

### SAFE FOR EXPLOSIVE ENVIRONMENTS

No arc leakage due to a hermetically sealed design

### HIGH RELIABILITY DESIGN

Hermetic sealing creates a stable environment for high voltage switching

### NO SPECIFIC MOUNTING ARRANGEMENT

Mountable in any orientation without reduction of performance

### VARIOUS APPLICATIONS

Battery disconnect, EV charging, energy storage systems, photovoltaics, power control, circuit protection and much more

## Sealing Type: Epoxy/Resin

- ✓ Compact design, optional auxiliary contacts available
- ✓ Bi-directional options



## Certification Information

1. Meet RoHS (2011/65/EU)
2. CE certified
3. UL approved

## Nomenclature

ALEV100 - B N H

### Series code:

"ALEV100" = ALEV100

### Type Code:

Blank = Main Contacts (NO)

### Coil Voltage Code:

"B" = 12VDC

"C" = 24VDC

"E" = 48VDC

### Options (applied in this order):

Blank = Std. Options (Bottom Mount, Without Aux, Contact & Polarized Load Terminals)

"A" = With Aux. Contact (SPST-NO)

"S" = Side Mount Version

"N" = Non-Polar Load Terminals

"H" = 1000 Volts Switching Voltage

## Performance Data for 900V Switching Option

MAIN CONTACT		
Contact Arrangement	1 Form X (SPST-NO)	
Rated Operating Voltage	12-900 VDC	
Continuous (Carry) Current	100A*1	
Short Time Over current	200A (3 minutes) *2	
Short Circuit Current	1,250A (1/2 cycle, 60Hz)	
Dielectric Withstanding Voltage (initial)	Between Open Contacts	2500VDC, $\leq 1\text{mA}$
	Between Contacts to Coil	2,200Vrms, $\leq 1\text{mA}$
Insulation Resistance (Initial)	Terminal to Terminal	New: Min 100 M $\Omega$ @500VDC End of Life: 50 M $\Omega$ @500VDC
	Terminals to Coil	
Voltage Drop (@100A)	$\leq 80\text{mV}$	

EXPECTED LIFE	
Electrical Life	See table below
Mechanical Life	200,000 Cycles

### Polarized Load

Voltage (VDC)	650	450
Current(A)	100	100
Electrical Life (cycles)	2,000	10,000

Note:

1. Do not meet dielectric & IR after the test.
2. ON:OFF= 1s:9s.
3. The ambient environment of the application should not cause any dewing or icing inside the relay. Otherwise, the relay may fail to work consequently.

OPERATE / RELEASE TIME	
Operate Time Close (includes bounce)	25ms, Max.
Release Time	10ms, Max.

ENVIRONMENTAL DATA		
Shock	Functional	196m/s <sup>2</sup> Sine half-wave pulse
	Destructive	490m/s <sup>2</sup> Sine half-wave pulse
Operating Temperature		-40 to +85 °C
Vibration, Sine, Peak, 20G		80 to 2,000Hz
Weight		0.42Lb (0.19kg)

COIL DATA			
Nominal Voltage	12VDC	24VDC	48VDC
Pickup voltage (20 °C)	9.6VDC	19.2VDC	38.4VDC
Dropout voltage (20 °C)	0.8VDC	1.6VDC	3.3VDC
Coil current (20°C, voltage rating, nominal)	461mA	250mA	122mA
Coil wattage (20°C, voltage rating, nominal)	5.5W	6W	6W
Rated coil resistance $\pm 5\%$ (20°C)	26 $\Omega$	96 $\Omega$	392 $\Omega$

AUX. CONTACT	
Aux. Contact Arrangement	1 Form A
Aux. Contact/Current Max.	2A@30VDC/3A@125VAC
Aux. Contact Current Min.	100mA@8V
Aux. Contact Resistance Max.	0.417ohms@30VDC/ 0.150ohms@125VAC

**Performance Data for ALEV100-H/1000V Switching Option**

**MAIN CONTACT**

Contact Arrangement	1 Form X (SPST-NO)	
Rated Operating Voltage	1000 VDC	
Rated Current	100A	
Max. Short Circuit Current	1250A (1s)	
Short Term Current	200A (3min)	
Dielectric Withstanding Voltage (initial)	Between Open Contacts	4000VDC 1mA 1min
	Between Contacts to Coil	2200VAC 1mA 1min
Insulation Resistance (Initial)	Terminal to Terminal	Min 1000 MΩ @1000VDC
	Terminals to Coil	
Contact Voltage Drop	Max. 5mV @10A	
Limit breaking	1500A@450VDC,1 Cycle	

**OPERATE / RELEASE TIME**

Operate Time Close (includes bounce)	25ms, Max. @20°C
Release Time	10ms, Max. @20°C

**ENVIRONMENTAL DATA**

Shock	Functional	196m/s <sup>2</sup> Sine half-wave pulse
	Destructive	490m/s <sup>2</sup> Sine half-wave pulse
Operating Temperature	-40 to +85 °C	
Humidity	5% to 85%RH	
Weight	0.42Lb (0.19kg)	

**EXPECTED LIFE**

Electrical Endurance (Make/Break)	100A@750V 500 Cycles
Electrical Endurance (Break only)	63A@1000V 500 Cycles
Mechanical Life	200,000 Cycles

**COIL DATA**

Nominal Voltage	12VDC	24VDC
Max. Pick-up Voltage (20°C)	9.6VDC	19.2VDC
Min Drop-out Voltage (20°C)	0.8VDC	1.6VDC
Coil Current (20°C)	5.5W	6W
Coil Current (20°C)	5.5W	6W
Coil Power (20°C)	26Ω	96Ω

**Current Carry Curve**

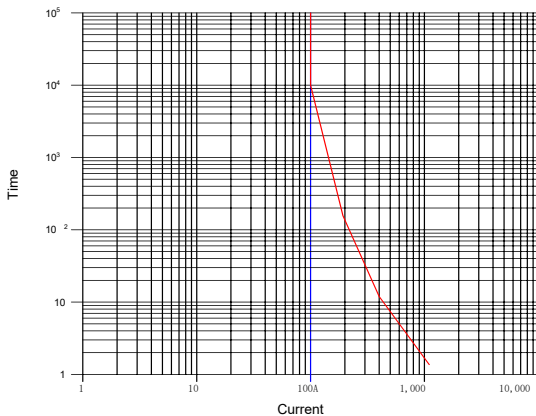

Note:

1. Do not meet dielectric & IR after the test.
2. ON:OFF= 0.6s:5.4s.
3. The ambient environment of the application should not cause any dewing or icing inside the relay. Otherwise, the relay may fail to work consequently.

**AUX. CONTACT**

Aux. Contact Arrangement	1 Form A
Aux. Contact Current Max.	2A@30VDC/3A@125VAC
Aux. Contact Current Min.	100mA@8V
Aux. Contact Resistance Max.	0.417ohms@30VDC/ 0.150ohms@125VAC

Outline Dimensions : inches (mm)

A. Bottom mount-Polar:

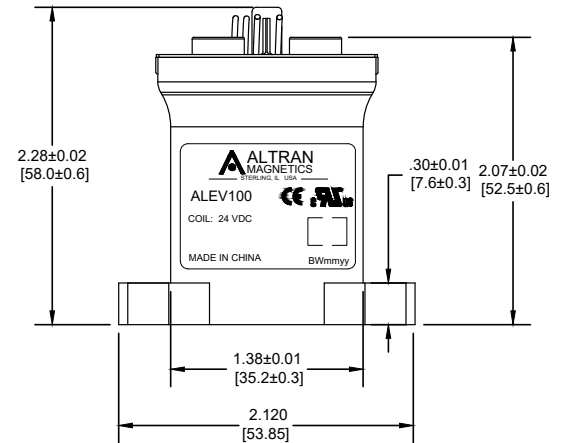
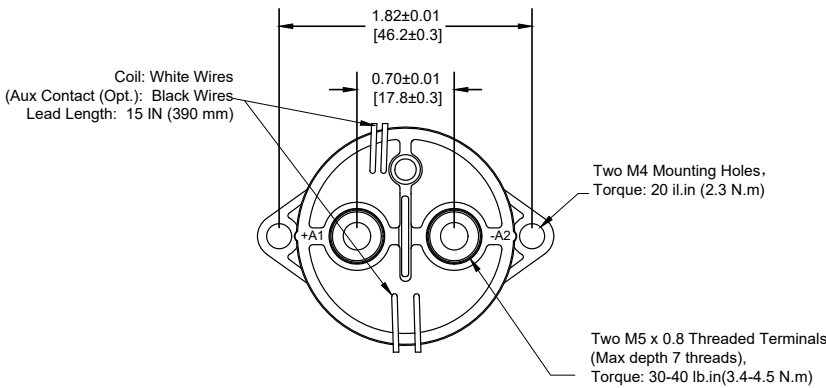

B. Side mount-Polar:

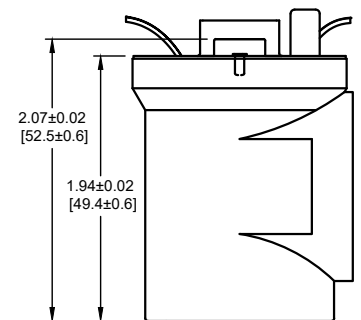
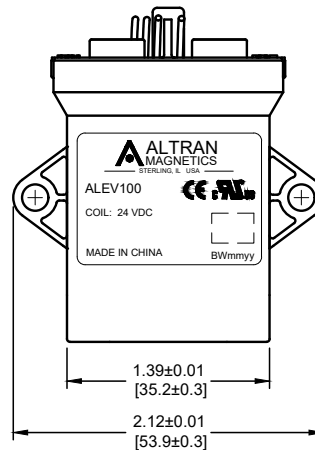
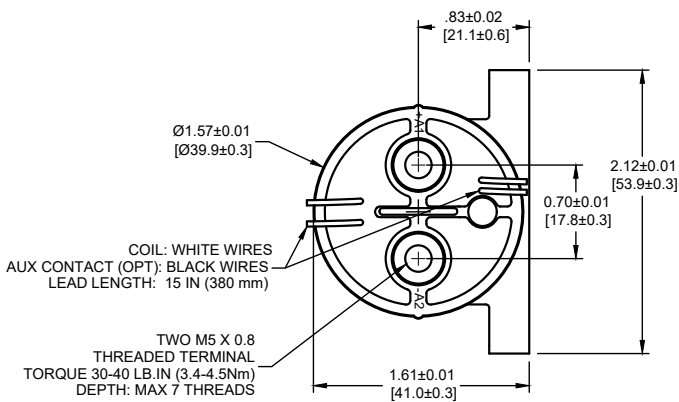

Notes:

1. The polarity of the product has the polarity of "+A1" and "-A2" on the outer cover, and the non-polar product has no polarity mark.
2. The wire size is 22 AWG.

Outline Dimensions : inches (mm)

**A. Bottom mount-Non-polar:**

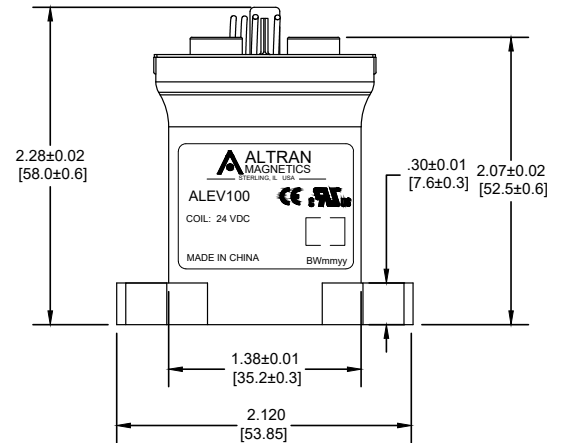
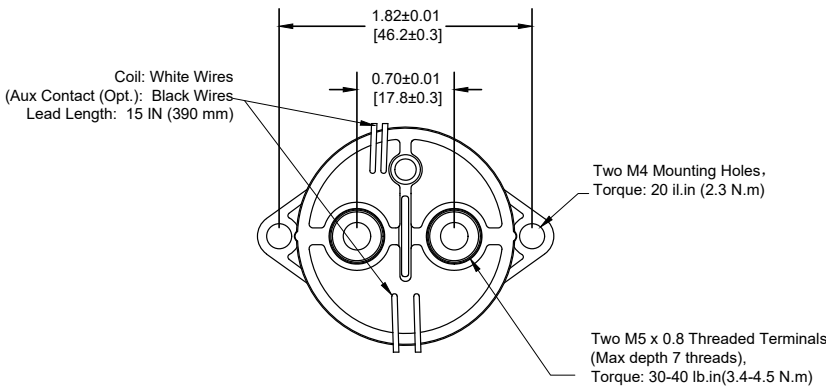

**B. Side mount-Non-polar:**

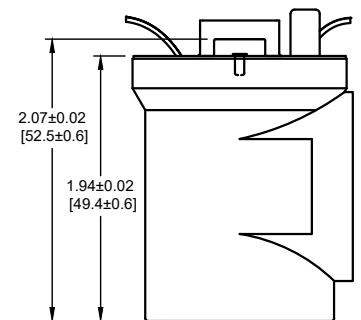
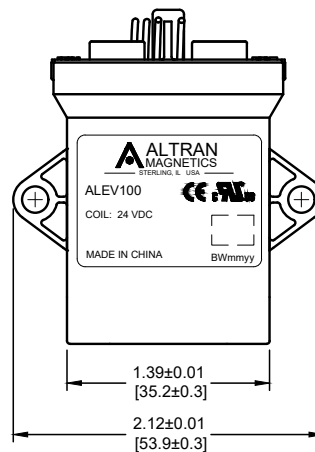
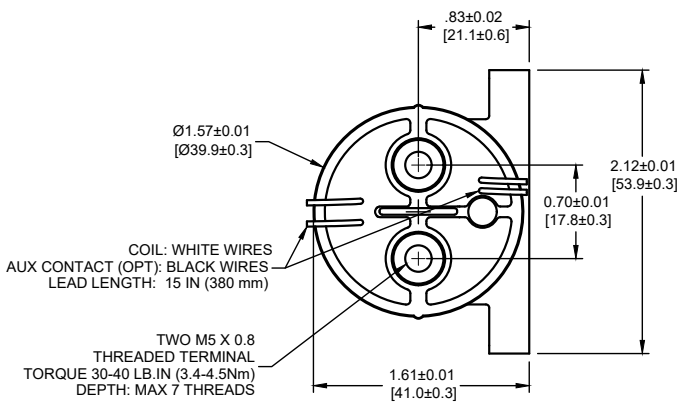

Notes:

1. The polarity of the product has the polarity of "+A1" and "-A2" on the outer cover, and the non-polar product has no polarity mark.
2. The wire size is 22 AWG.

## Application Notes

1. Be sure to use split washers to prevent nuts from loosening, all the terminals or conductors must be in direct contact with the contactor's terminals. Nut tightening torque is specified below. Exceeding the maximum torque can lead to product failure.
  - a. Contact torque: 30 - 40 lb.in (3.4 - 4.5 N.m) Max.
  - b. Mounting torque: 20 lb.in (2.3 N.m)
2. Contact terminals are polarized so refer to drawing during connecting. We suggest using a varistor rather than diode as a surge protector.
3. Do not use if dropped.
4. Avoid installing in a strong magnetic field (close to a transformer or magnet), or near a heat source.
5. Electrical life:  
Use per load capability and life cycle limits so as not to cause a function failure (treat the contactor as a product with specified life and replace it when necessary). It is possible to make parts burn around the contactor once operating failure occurs. It is necessary to take layout into account and to make sure power shall be cut off within 1 second.
6. Lifetime of internal gas diffusion:  
The contactor is sealed and filled with gas, lifetime of gas diffusion is determined by temperature in contact chamber (ambient temperature + temperature generated by contact operation). Operate only in an ambient temperature from -40 to +85 °C.
7. Coil drive power must be greater than coil power or it will reduce performance capability.
8. Avoid debris or oil contamination on the main terminals to optimize contact and avoid excess heat generation.