

Safety Control Unit SG-EFS 134 ZK2/1 LR Operating Instructions with automatic or manual reset

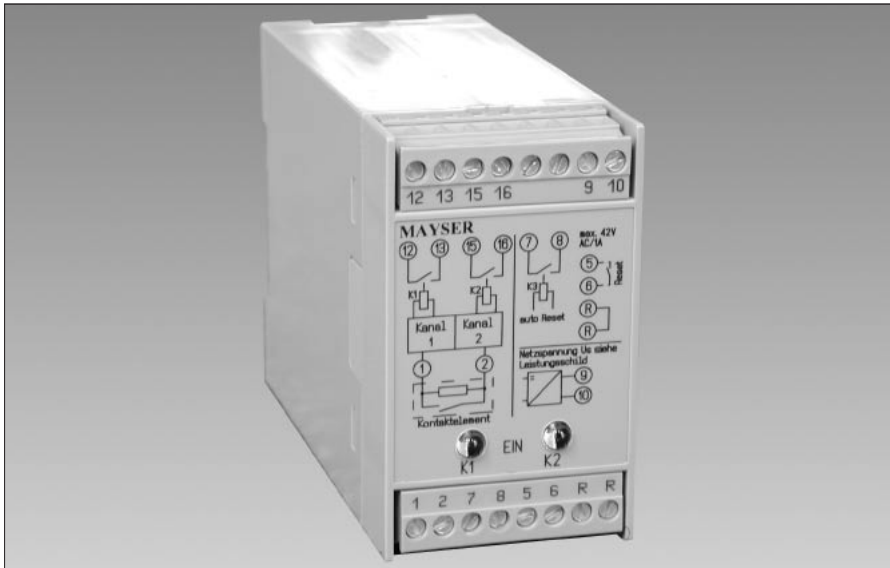

Safety Control Unit with EEC-type-examination Safety Category 3 in accordance to EN 954-1

with forceguided contacts for increased safety requirements;
for Pressure Sensitive Mats, Safety Edges and Safety Bumpers with 8.2 kΩ monitoring resistor.

These operating instructions apply to the following Control Units:

SG-EFS 134 ZK2/1 LR 230 V~

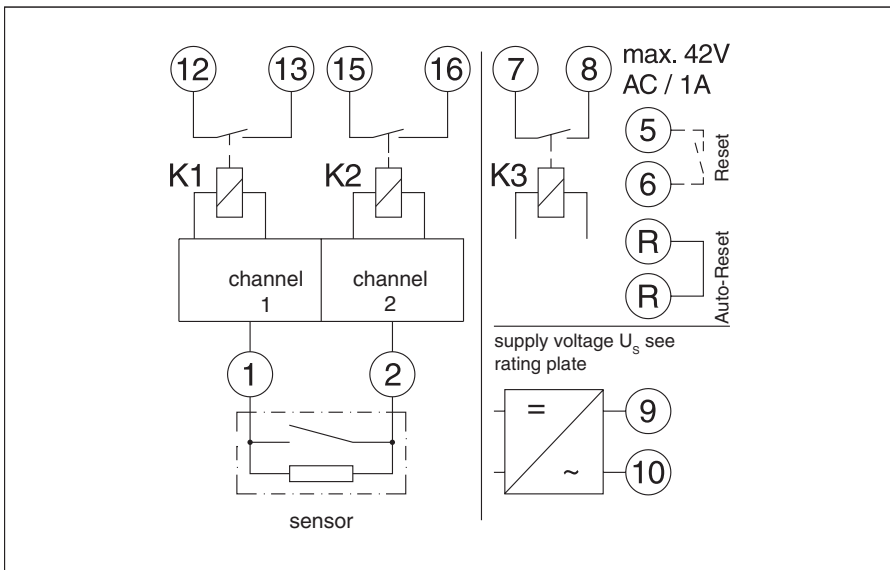

Control

The single-fault-safe electronics module has two channels (redundant). Each channel triggers a force guided relay. The relays self-test by contact return after each switching cycle. The electronics monitor the electrical resistance of the connected sensors which have a specific closed-circuit current. When the sensors are not activated, both output relays are energized and both yellow LEDs light. If a sensor is activated, or a break occurs in the supply to the Control Unit, relays K1 and K2 de-energize and the LEDs go out.

Enclosure

W × H × D (mm)	45 x 75 x 105
Protection class	IP 40
Plug-in connectors	each 8-channel
Cable clamps	max. 2.5 mm ²
Weight	~ model approx. 280 g

Notes on protection class:
The units may only be used in locations with a minimum protection class of IP54 (eg. cabinet).

Parts supplied

- Control Unit
- Enclosure with electronics module and plug-in connectors.
- Operating Instructions

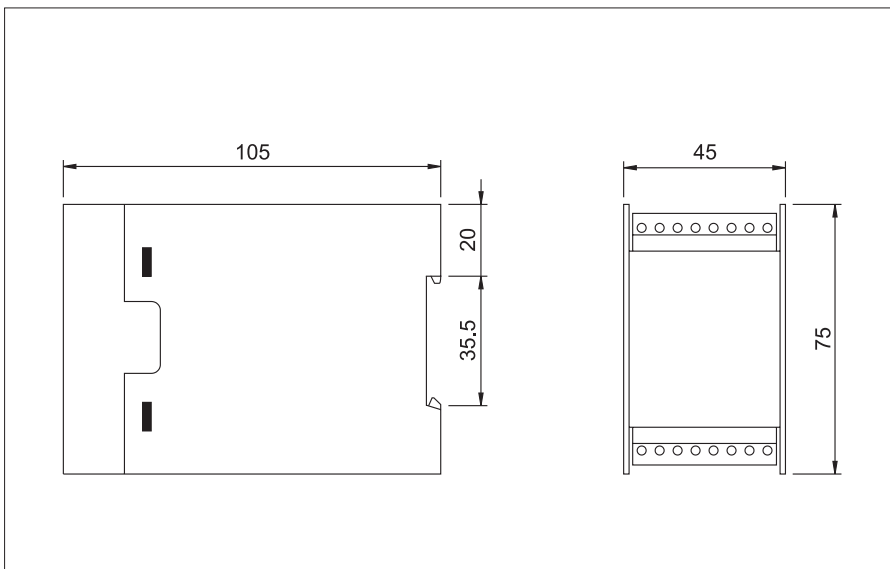

Safety Control Unit SG-EFS 134 ZK2/1 LR

IMPORTANT NOTES!

To ensure correct and safe operation of the unit, it must be properly transported and stored, properly installed and commissioned, and operated in accordance with its purpose. Only persons familiar with the installation, commissioning and operation, and with the corresponding qualifications to prove their skills, may work on the units. They must observe the contents of these instructions, the notes given on the type plate of the unit and the safety requirements relevant to the installation and operation of electrical systems. This unit is con-

Please read!

structed and tested to EN 1760 and left our factory in perfect condition with regard to safety. In order to maintain this state, you must observe the safety regulations marked "**WARNING!**" in these operating instructions. Failure to observe the safety regulations can lead to death, injury to personnel, or damage to the unit and other systems and equipment. Should the information given in these operating instructions be inadequate in any way, please contact your local technical centre, subsidiary or representative.

When using the device outside the European Union, you must observe the relevant regulations valid for the country of use.

2 connection variants:

- SG-EFS 134 ZK2/1 LR with manual reset

Bridge R, R must be removed

After deactivation of the unit by the sensor it must be re-activated by means of an external reset button. The cable break transmitting relay K3 provides a make contact that opens when a break in connection occurs. This signal remains intact until the Control Unit is reactivated by switching the supply power off and on.

- SG-EFS 134 ZK2/1 LR with automatic reset

Bridge R, R must be in place

The unit becomes active again as soon as the sensor is no longer activated. The cable break transmitting relay K3 provides a make contact that opens when a break in connection occurs. This signal remains intact until the Control Unit is reactivated by switching the supply power off and on.

WARNING!

Not for safety circuit:

- Der cable break transmitting contact 7, 8 is solely for information purposes and must not be connected into the safety circuit.

Do not cross link Control Units:

- Clamps 5, 6 as well as R, R and 1, 2 are not voltage free and thus may not be cross linked with further Control Units.

Technical Data

Connecting voltage U_s

SG-EFS 134 ZK2/1 LR	AC 230 V
Voltage tolerance	-15% to +10%
Nominal frequency	50 Hz
Frequency tolerance	48 - 62 Hz
Power consumption	< 5 VA for AC

Sensor voltage

DC 15 V

Control Unit Outputs

Switching channel K1 and K2	12, 13 and 15, 16	
Switching voltage	max. AC 240 V	max. DC 24 V
Switching current	4 A	1 A
Cable break transmitting relay K3	7, 8	
Switching voltage	max. AC 42 V	max. DC 42 V
Switching current	1 A	1 A

Permissible ambient temp. - 20 °C to + 50 °C

Note:

When switching inductive loads the user must be fitted out with spark absorbers.

Installation and Operation

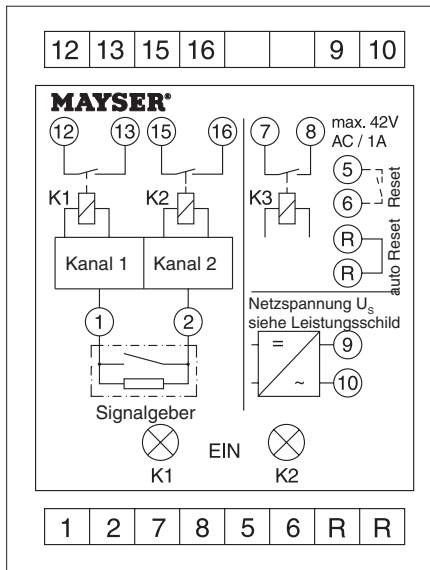

Installation

The enclosure of the Control Unit can be mounted in any position:
 - on a 35 mm EN 50022 rail
 Wiring is carried out in the cable clamps of the plug-in connection:

Sensor	1, 2
Supply voltage	9, 10
Switching channel K1	12, 13
Switching channel K2	15, 16
Cable break K3	7, 8
Reset button	5, 6
for automatic reset only:	
Bridge	R, R

Commissioning

After connecting up sensors, switching contacts and power, carry out a function test in the following order:

Sensor not activated

- both yellow LEDs on
- output relays K1, K2 are energized
- cable break transmitting relay K3 is energized

Activate sensor

- both yellow LEDs go out
- output relays K1, K2 deenergize
- cable break transmitting relay K3 deenergizes

WARNING!

Do not release terminals or remove the plug-in connection with power on.

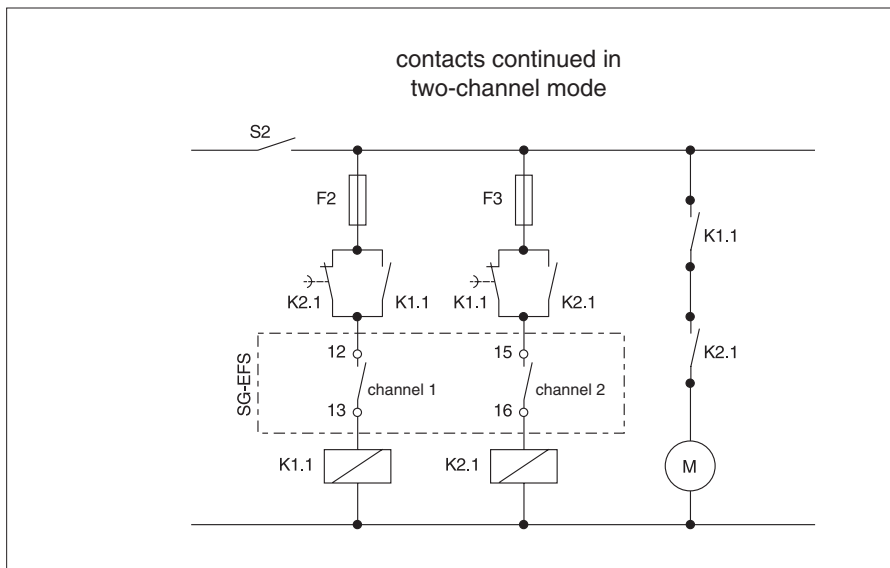

Important notes:

- **Supply voltage**
must be in accordance with the connecting voltage U_s indicated on the type plate.
- **Permissible temperature range**
If installing into a cabinet, maintain sufficient distance from heat sources (min. 2 cm).
- **Wiring**
Wire direct to the control circuit or continue two-channel mode to the next circuit.
Fuse the relay contacts externally (risk of welding).

Maintenance

The Control Unit is maintenance-free.
 Check the safety installation monthly by activating the sensors.

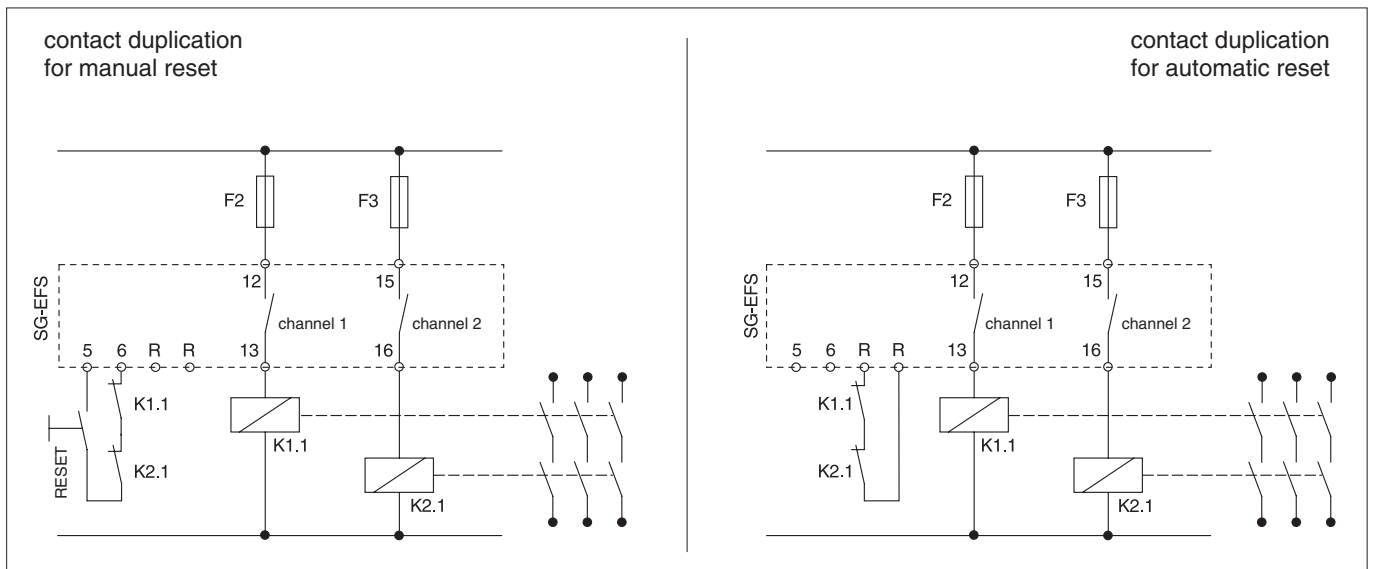

Check sensor

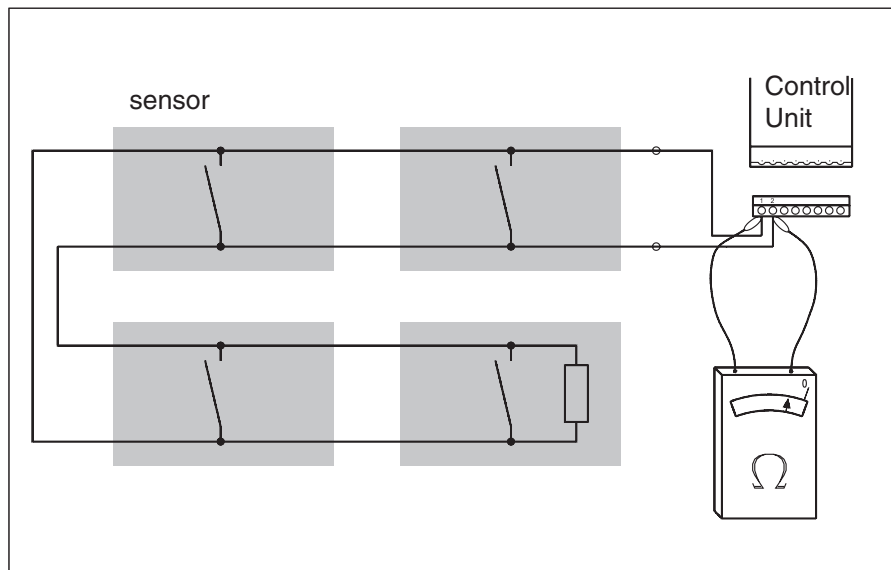

Check combination of sensors

Resistance measurement:
Disconnect power to the unit.
Unplug plug-in connection and measure (1, 2) with an ohmmeter:

not activated	c. 8.2 kΩ
activated	< 150 Ω

If the values measured deviate considerably from the set values, the sensors have to be checked individually (see below).

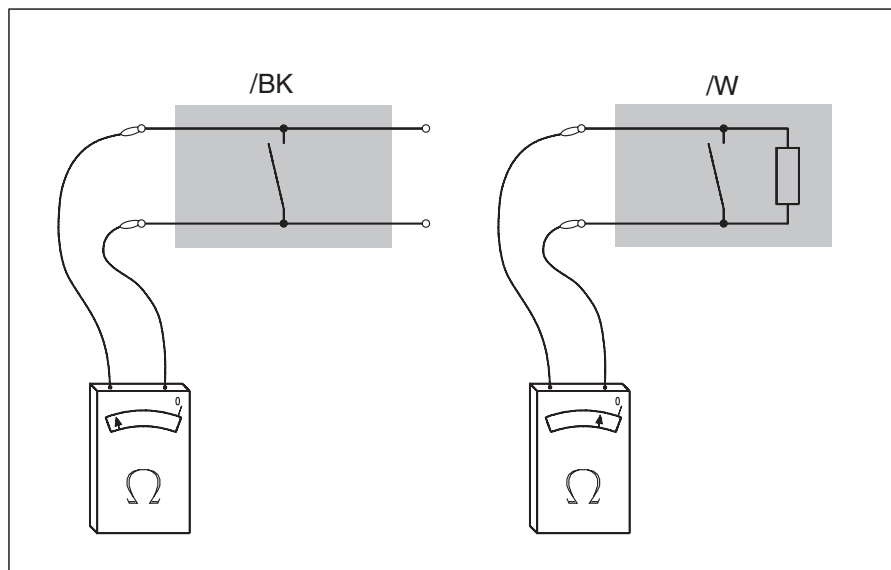

Check individual sensors

Resistance measurement:
Measure each individual sensor with an ohmmeter:

/BK	not activated	infinite Ω
	activated	< 150 Ω
/W	not activated	c. 8.2 kΩ
	activated	< 150 Ω

Check also cables and cable connections.

Damaged or faulty sensors must be repaired or replaced immediately by a specialist.

Only a functioning system can ensure maximum safety!

Troubleshooting and remedies

Prerequisite: SG-EFS connected to power supply, sensor not activated.

- yellow LEDs off, relay K1 and K2 are de-energized:

- > supply voltage off or incorrect
 - ☞ Check supply voltage, compare with type plate.
- > Faulty sensor or supply lines (break in connection or short circuit)
 - ☞ Connect 8.2 kΩ resistor instead of sensor. If the yellow LEDs off, the Control Unit is faulty

- one yellow LED is on:

- > fault in Control Unit
Control Unit faulty.

- Cable break transmitting relay K3 de-energized:

- > supply voltage off or incorrect
 - ☞ Check supply voltage, compare with type plate.
- > Faulty sensor or supply lines (break in connection)
 - ☞ Check sensor and supply lines, switch Control Unit off and on again, if the sensor is functioning correctly relay K3 must energize, otherwise the Control Unit is faulty.

Problem not solved? – The Mayser Support Team can help:
tel. +49 (0)731 2061-0

Subject to technical modifications.