

# SN74LV4052A Dual 4-Channel Analog Multiplexers and Demultiplexers

## 1 Features

- 1.65V to 5.5V  $V_{CC}$  operation
- Fast switching
- High on-off output-voltage ratio
- Low crosstalk between switches
- Extremely low input current
- Latch-up performance exceeds 100mA per JESD 78, class II
- ESD protection exceeds JESD 22:
  - 2000V human-body model (A114-A)
  - 1000V charged-device model (C101)

## 2 Applications

- [Telecommunications](#)
- [Infotainment](#)
- Signal gating and isolation
- [Home appliances](#)
- Programmable logic circuits
- Modulation and demodulation

## 3 Description

The SNx4LV4052A device is a dual, 4-channel CMOS analog multiplexer and demultiplexer that is designed for 1.65V to 5.5V  $V_{CC}$  operation.

The SNx4LV4052A device handles both analog and digital signals. Each channel permits signals with amplitudes up to 5.5V (peak) to be transmitted in either direction.

### Package Information

PART NUMBER	PACKAGE <sup>(1)</sup>	PACKAGE SIZE <sup>(2)</sup>
SNx4LV4052A	D (SOIC, 16)	9.9mm × 6mm
	PW (TSSOP, 16)	5mm × 6.4mm
	RGY (VQFN, 16)	4mm × 3.5mm
	DYY (SOT-23-THIN, 16)	4.2mm x 3.26mm

(1) For more information, see [Section 11](#).

(2) The package size (length × width) is a nominal value and includes pins, where applicable.

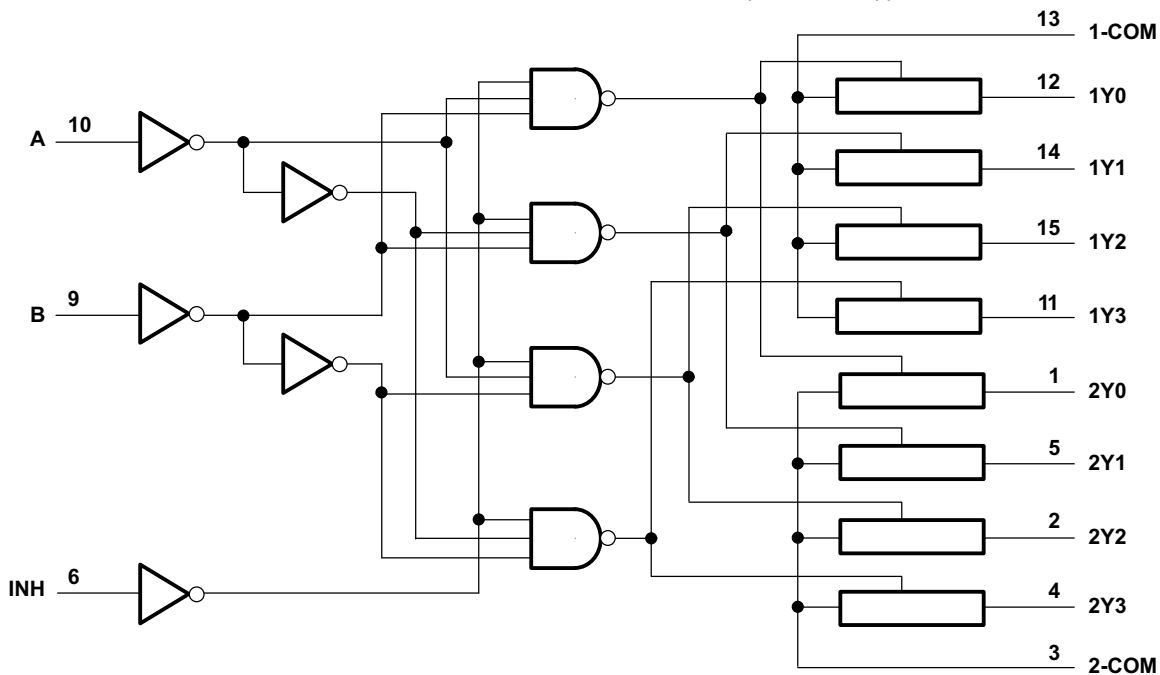

Copyright © 2016, Texas Instruments Incorporated

Logic Diagram (Positive Logic)



## Table of Contents

<b>1 Features</b> .....	1	7.2 Functional Block Diagram.....	14
<b>2 Applications</b> .....	1	7.3 Feature Description.....	14
<b>3 Description</b> .....	1	7.4 Device Functional Modes.....	14
<b>4 Pin Configuration and Functions</b> .....	3	<b>8 Application and Implementation</b> .....	15
<b>5 Specifications</b> .....	4	8.1 Application Information.....	15
5.1 Absolute Maximum Ratings.....	4	8.2 Typical Application.....	15
5.2 ESD Ratings.....	4	8.3 Power Supply Recommendations.....	16
5.3 Thermal Information: SN74LV4052A.....	4	8.4 Layout.....	16
5.4 Recommended Operating Conditions.....	5	<b>9 Device and Documentation Support</b> .....	18
5.5 Electrical Characteristics.....	5	9.1 Documentation Support.....	18
5.6 Timing Characteristics $V_{CC} = 2.5\text{ V} \pm 0.2\text{ V}$ .....	7	9.2 Receiving Notification of Documentation Updates....	18
5.7 Timing Characteristics $V_{CC} = 3.3\text{ V} \pm 0.3\text{ V}$ .....	7	9.3 Support Resources.....	18
5.8 Timing Characteristics $V_{CC} = 5\text{ V} \pm 0.5\text{ V}$ .....	8	9.4 Trademarks.....	18
5.9 AC Characteristics.....	8	9.5 Electrostatic Discharge Caution.....	18
5.10 Typical Characteristics.....	9	9.6 Glossary.....	18
<b>6 Parameter Measurement Information</b> .....	10	<b>10 Revision History</b> .....	18
<b>7 Detailed Description</b> .....	14	<b>11 Mechanical, Packaging, and Orderable Information</b> .....	19
7.1 Overview.....	14		

## 4 Pin Configuration and Functions

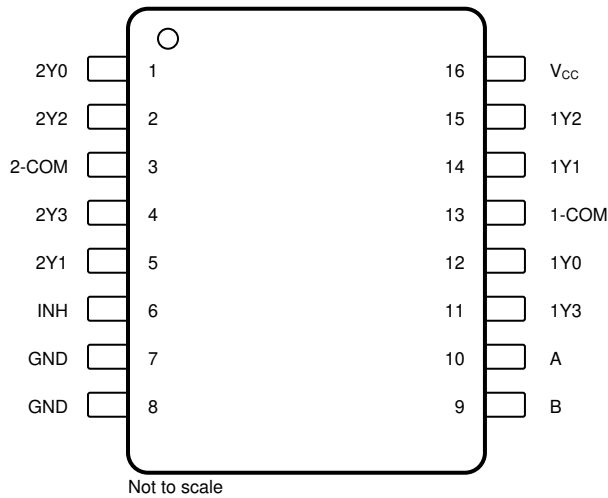

**Figure 4-1. D, PW, or DYY Packages, 16-Pin SOIC, TSSOP, or SOT-23-THIN (Top View)**

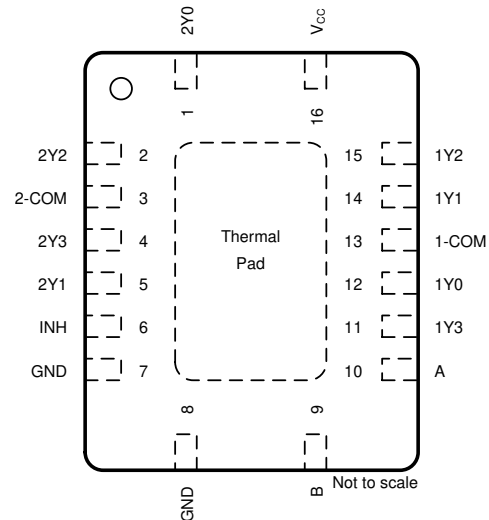

**Figure 4-2. RGY Package, 16-Pin VQFN With Thermal Pad (Top View)**

**Table 4-1. Pin Functions**

PIN		TYPE <sup>(1)</sup>	DESCRIPTION
NAME	NO.		
2Y0	1	I/O	Port 2 channel 0
2Y2	2	I/O	Port 2 channel 2
2-COM	3	I/O	Port 2 common channel
2Y3	4	I/O	Port 2 channel 3
2Y1	5	I/O	Port 2 channel 1
INH	6	I	Inhibit input
GND	7	—	Device ground
GND	8	—	Device ground
B	9	I	Logic input selector B
A	10	I	Logic input selector A
1Y3	11	I/O	Port 1 channel 3
1Y0	12	I/O	Port 1 channel 0
1-COM	13	I/O	Port 1 common channel
1Y1	14	I/O	Port 1 channel 1
1Y2	15	I/O	Port 1 channel 2
V <sub>CC</sub>	16	—	Device power

(1) I = input, O = output

## 5 Specifications

### 5.1 Absolute Maximum Ratings

over operating free-air temperature range (unless otherwise noted)<sup>(1) (3)</sup>

		MIN	MAX	UNIT
V <sub>CC</sub>	Supply voltage	-0.5	7.0	V
V <sub>I</sub>	Logic input voltage range	-0.5	7.0	V
V <sub>IO</sub>	Switch I/O voltage range <sup>(2) (3)</sup>	-0.5	V <sub>CC</sub> + 0.5	V
I <sub>IK</sub>	Input clamp current	V <sub>I</sub> < 0		mA
I <sub>IOK</sub>	Switch IO diode clamp current	V <sub>IO</sub> < 0 or V <sub>IO</sub> > V <sub>CC</sub>	50	mA
I <sub>T</sub>	Switch continuous current	V <sub>IO</sub> = 0 to V <sub>CC</sub>	±25	mA
	Continuous current through V <sub>CC</sub> or GND		±50	mA
T <sub>J</sub>	Junction temperature		150	°C
T <sub>stg</sub>	Storage temperature	-65	150	°C

- (1) Operation outside the *Absolute Maximum Ratings* may cause permanent device damage. Absolute maximum ratings do not imply functional operation of the device at these or any other conditions beyond those listed under *Recommended Operating Conditions*. If briefly operating outside the *Recommended Operating Conditions* but within the *Absolute Maximum Ratings*, the device may not sustain damage, but it may not be fully functional. Operating the device in this manner may affect device reliability, functionality, performance, and shorten the device lifetime.
- (2) Pins are diode-clamped to the power-supply rails. Over voltage signals must be voltage and current limited to maximum ratings.
- (3) This value is limited to 5.5 V maximum

### 5.2 ESD Ratings

			VALUE	UNIT	
V <sub>(ESD)</sub>	Electrostatic discharge	Human body model (HBM), per AEC Q100-002 <sup>(1)</sup>	All pins	±4000	V
		Charged device model (CDM), per AEC Q100-011	All pins	±2000	

- (1) AEC Q100-002 indicates that HBM stressing shall be in accordance with the ANSI/ESDA/JEDEC JS-001 specification.

### 5.3 Thermal Information: SN74LV4052A

THERMAL METRIC <sup>(1)</sup>		SN74LV4052A	SN74LV4052A	SN74LV4052A	SN74LV4052A	UNIT
		D (SOIC)	PW (TSSOP)	RGY (VQFN)	DYY (SOT)	
		16 PINS	16 PINS	16 PINS	16 PINS	
R <sub>θJA</sub>	Junction-to-ambient thermal resistance	115.2	140.2	89.4	199.7	°C/W
R <sub>θJC(top)</sub>	Junction-to-case (top) thermal resistance	75.0	72.6	89.7	121.2	°C/W
R <sub>θJB</sub>	Junction-to-board thermal resistance	76.6	98.7	65.4	129.0	°C/W
Ψ <sub>JT</sub>	Junction-to-top characterization parameter	31.3	13.4	25.0	24.6	°C/W
Ψ <sub>JB</sub>	Junction-to-board characterization parameter	75.7	97.3	65.2	126.7	°C/W
R <sub>θJC(bot)</sub>	Junction-to-case (bottom) thermal resistance	N/A	N/A	48.9	N/A	°C/W

- (1) For more information about traditional and new thermal metrics, see the [Semiconductor and IC Package Thermal Metrics](#) application report.

## 5.4 Recommended Operating Conditions

over operating free-air temperature range (unless otherwise noted)<sup>(1)</sup>

		MIN	NOM	MAX	UNIT
V <sub>CC</sub>	Supply voltage	1 <sup>(2)</sup>		5.5	V
V <sub>IH</sub>	High-level input voltage, logic control inputs	V <sub>CC</sub> = 1.65		5.5	V
		V <sub>CC</sub> = 2 V		5.5	
		V <sub>CC</sub> = 2.3 V to 2.7 V	V <sub>CC</sub> × 0.7	5.5	
		V <sub>CC</sub> = 3 V to 3.6 V	V <sub>CC</sub> × 0.7	5.5	
		V <sub>CC</sub> = 4.5 V to 5.5 V	V <sub>CC</sub> × 0.7	5.5	
V <sub>IL</sub>	Low-level input voltage, logic control inputs	V <sub>CC</sub> = 1.65		0.4	V
		V <sub>CC</sub> = 2 V		0.5	
		V <sub>CC</sub> = 2.3 V to 2.7 V	0	V <sub>CC</sub> × 0.3	
		V <sub>CC</sub> = 3 V to 3.6 V	0	V <sub>CC</sub> × 0.3	
		V <sub>CC</sub> = 4.5 V to 5.5 V	0	V <sub>CC</sub> × 0.3	
V <sub>I</sub>	Logic control input voltage	0		5.5	V
V <sub>IO</sub>	Switch input or output voltage	0		V <sub>CC</sub>	V
Δt/ΔV	Logic input transition rise or fall rate	V <sub>CC</sub> = 2.3 V to 2.7 V		200	ns/V
		V <sub>CC</sub> = 3 V to 3.6 V		100	
		V <sub>CC</sub> = 4.5 V to 5.5 V		20	
T <sub>A</sub>	Ambient temperature	–40		125	°C

- (1) All unused inputs of the device must be held at V<sub>CC</sub> or GND to ensure proper device operation. Refer to TI application report *Implications of Slow or Floating CMOS Inputs*, SCBA004.
- (2) When using a V<sub>CC</sub> of ≤1.2 V, it is recommended to use these devices only for transmitting digital signals. When supply voltage is near 1.2 V the analog switch ON resistance becomes very non-linear

## 5.5 Electrical Characteristics

over recommended operating free-air temperature range (unless otherwise noted)

PARAMETER	Condition	T <sub>A</sub>	V <sub>CC</sub>	MIN	TYP	MAX	UNIT
r <sub>ON</sub>	ON-state switch resistance	I <sub>T</sub> = 2 mA, V <sub>I</sub> = V <sub>CC</sub> or GND, V <sub>INH</sub> = V <sub>IL</sub>	25°C	1.65 V		60 150	Ω
r <sub>ON</sub>	ON-state switch resistance	I <sub>T</sub> = 2 mA, V <sub>I</sub> = V <sub>CC</sub> or GND, V <sub>INH</sub> = V <sub>IL</sub>	–40°C to 85°C	1.65 V		225	Ω
r <sub>ON</sub>	ON-state switch resistance	I <sub>T</sub> = 2 mA, V <sub>I</sub> = V <sub>CC</sub> or GND, V <sub>INH</sub> = V <sub>IL</sub>	–40°C to 125°C	1.65 V		225	Ω
r <sub>ON</sub>	ON-state switch resistance	I <sub>T</sub> = 2 mA, V <sub>I</sub> = V <sub>CC</sub> or GND, V <sub>INH</sub> = V <sub>IL</sub>	25°C	2.3 V		38 180	Ω
			–40°C to 85°C			225	
			–40°C to 125°C			225	
			25°C	3 V		30 150	Ω
			–40°C to 85°C			190	
			–40°C to 125°C			190	
			25°C	4.5 V		22 75	Ω
			–40°C to 85°C			100	
			–40°C to 125°C			100	
r <sub>ON(p)</sub>	Peak ON-state resistance	I <sub>T</sub> = 2 mA, V <sub>I</sub> = GND to V <sub>CC</sub> , V <sub>INH</sub> = V <sub>IL</sub>	25°C	1.65 V		220 600	Ω

## 5.5 Electrical Characteristics (continued)

over recommended operating free-air temperature range (unless otherwise noted)

PARAMETER		Condition	T <sub>A</sub>	V <sub>CC</sub>	MIN	TYP	MAX	UNIT
r <sub>ON(p)</sub>	Peak ON-state resistance	I <sub>T</sub> = 2 mA, V <sub>I</sub> = GND to V <sub>CC</sub> , V <sub>INH</sub> = V <sub>IL</sub>	–40°C to 85°C	1.65 V			700	Ω
r <sub>ON(p)</sub>	Peak ON-state resistance	I <sub>T</sub> = 2 mA, V <sub>I</sub> = GND to V <sub>CC</sub> , V <sub>INH</sub> = V <sub>IL</sub>	–40°C to 125°C	1.65 V			700	Ω
r <sub>ON(p)</sub>	Peak ON-state resistance	I <sub>T</sub> = 2 mA, V <sub>I</sub> = GND to V <sub>CC</sub> , V <sub>INH</sub> = V <sub>IL</sub>	25°C	2.3 V		113	500	Ω
			–40°C to 85°C			600		
			–40°C to 125°C			600		
			25°C	3 V		54	180	Ω
			–40°C to 85°C			225		
			–40°C to 125°C			225		
			25°C	4.5 V		31	100	Ω
			–40°C to 85°C			125		
			–40°C to 125°C			125		
Δr <sub>ON</sub>	Difference in ON-state resistance between switches	I <sub>T</sub> = 2 mA, V <sub>I</sub> = GND to V <sub>CC</sub> , V <sub>INH</sub> = V <sub>IL</sub>	25°C	1.65 V		3	40	Ω
Δr <sub>ON</sub>	Difference in ON-state resistance between switches	I <sub>T</sub> = 2 mA, V <sub>I</sub> = GND to V <sub>CC</sub> , V <sub>INH</sub> = V <sub>IL</sub>	–40°C to 85°C	1.65 V			50	Ω
Δr <sub>ON</sub>	Difference in ON-state resistance between switches	I <sub>T</sub> = 2 mA, V <sub>I</sub> = GND to V <sub>CC</sub> , V <sub>INH</sub> = V <sub>IL</sub>	–40°C to 85°C	1.65 V			50	Ω
Δr <sub>ON</sub>	Difference in ON-state resistance between switches	I <sub>T</sub> = 2 mA, V <sub>I</sub> = GND to V <sub>CC</sub> , V <sub>INH</sub> = V <sub>IL</sub>	25°C	2.3 V		2.1	30	Ω
			–40°C to 85°C			40		
			–40°C to 125°C			40		
			25°C	3 V		1.4	20	Ω
			–40°C to 85°C			30		
			–40°C to 125°C			30		
			25°C	4.5 V		1.3	15	Ω
			–40°C to 85°C			20		
			–40°C to 125°C			20		
I <sub>IH</sub> I <sub>IL</sub>	Control input current	V <sub>I</sub> = 5.5 V or GND	25°C	0 to 5.5 V			0.1	μA
			–40°C to 85°C			1		
			–40°C to 125°C			2		
I <sub>S(off)</sub>	OFF-state switch leakage current	V <sub>I</sub> = V <sub>CC</sub> and V <sub>O</sub> = GND, or V <sub>I</sub> = GND and V <sub>O</sub> = V <sub>CC</sub> , V <sub>INH</sub> = V <sub>IH</sub>	25°C	5.5 V			0.1	μA
			–40°C to 85°C			1		
			–40°C to 125°C			2		
I <sub>S(on)</sub>	ON-state switch leakage current	V <sub>I</sub> = V <sub>CC</sub> or GND, V <sub>INH</sub> = V <sub>IL</sub> (see Figure4)	25°C	5.5 V			0.1	μA
			–40°C to 85°C			1		
			–40°C to 125°C			2		
I <sub>CC</sub>	Supply current	V <sub>I</sub> = V <sub>CC</sub> or GND V <sub>INH</sub> = 0 V	25°C	5.5 V		0.01	μA	
			–40°C to 85°C			20		
			–40°C to 125°C			40		
C <sub>IC</sub>	Control input capacitance	f = 10 MHz	25°C	3.3 V		2		pF

## 5.5 Electrical Characteristics (continued)

over recommended operating free-air temperature range (unless otherwise noted)

PARAMETER		Condition	T <sub>A</sub>	V <sub>CC</sub>	MIN	TYP	MAX	UNIT
C <sub>OS</sub>	Switch terminal capacitance	f = 10 MHz	25°C	3.3 V		5		pF
C <sub>IS</sub>	Common terminal capacitance	f = 10 MHz	25°C	3.3 V		23		pF
C <sub>OS(on)</sub>	Common terminal ON-capacitance	f = 10 MHz	25°C	3.3 V		23		pF
C <sub>F</sub>	Feedthrough capacitance	f = 10 MHz	25°C	3.3 V		0.5		pF
C <sub>PD</sub>	Power dissipation capacitance	C <sub>L</sub> = 50 pF, f = 10 MHz	25°C	3.3 V		6		pF

## 5.6 Timing Characteristics V<sub>CC</sub> = 2.5 V ± 0.2 V

PARAMETER		FROM (INPUT)	TO (OUTPUT)	CONDITIONS	T <sub>A</sub>	MIN	TYP	MAX	UNIT
t <sub>PLH</sub> t <sub>PHL</sub>	Propagation delay time	COM or Yn	Yn or COM	C <sub>L</sub> = 15 pF	25°C		1.9	10	ns
					-40°C to 85°C			16	
					-40°C to 125°C			18	
t <sub>PZH</sub> t <sub>PZL</sub>	Enable delay time	INH	COM or Yn	C <sub>L</sub> = 15 pF	25°C		6.6	18	ns
					-40°C to 85°C			23	
					-40°C to 125°C			25	
t <sub>PHZ</sub> t <sub>PLZ</sub>	Disable delay time	INH	COM or Yn	C <sub>L</sub> = 15 pF	25°C		7.4	18	ns
					-40°C to 85°C			23	
					-40°C to 125°C			25	
t <sub>PLH</sub> t <sub>PHL</sub>	Propagation delay time	COM or Yn	Yn or COM	C <sub>L</sub> = 50 pF	25°C		3.8	12	ns
					-40°C to 85°C			18	
					-40°C to 125°C			20	
t <sub>PZH</sub> t <sub>PZL</sub>	Enable delay time	INH	COM or Yn	C <sub>L</sub> = 50 pF	25°C		7.8	28	ns
					-40°C to 85°C			35	
					-40°C to 125°C			35	
t <sub>PHZ</sub> t <sub>PLZ</sub>	Disable delay time	INH	COM or Yn	C <sub>L</sub> = 50 pF	25°C		11.5	28	ns
					-40°C to 85°C			35	
					-40°C to 125°C			35	

## 5.7 Timing Characteristics V<sub>CC</sub> = 3.3 V ± 0.3 V

PARAMETER		FROM (INPUT)	TO (OUTPUT)	CONDITIONS	T <sub>A</sub>	MIN	TYP	MAX	UNIT
t <sub>PLH</sub> t <sub>PHL</sub>	Propagation delay time	COM or Yn	Yn or COM	C <sub>L</sub> = 15 pF	25°C		1.2	6	ns
					-40°C to 85°C			10	
					-40°C to 125°C			12	
t <sub>PZH</sub> t <sub>PZL</sub>	Enable delay time	INH	COM or Yn	C <sub>L</sub> = 15 pF	25°C		4.7	12	ns
					-40°C to 85°C			15	
					-40°C to 125°C			18	
t <sub>PHZ</sub> t <sub>PLZ</sub>	Disable delay time	INH	COM or Yn	C <sub>L</sub> = 15 pF	25°C		5.7	12	ns
					-40°C to 85°C			15	
					-40°C to 125°C			18	

### 5.7 Timing Characteristics $V_{CC} = 3.3 \text{ V} \pm 0.3 \text{ V}$ (continued)

PARAMETER		FROM (INPUT)	TO (OUTPUT)	CONDITIONS	$T_A$	MIN	TYP	MAX	UNIT
$t_{PLH}$ $t_{PHL}$	Propagation delay time	COM or Yn	Yn or COM	$C_L = 50 \text{ pF}$	25°C		2.5	9	ns
					-40°C to 85°C			12	
					-40°C to 125°C			14	
$t_{PZH}$ $t_{PZL}$	Enable delay time	INH	COM or Yn	$C_L = 50 \text{ pF}$	25°C		5.5	20	ns
					-40°C to 85°C			25	
					-40°C to 125°C			25	
$t_{PHZ}$ $t_{PLZ}$	Disable delay time	INH	COM or Yn	$C_L = 50 \text{ pF}$	25°C		8.8	20	ns
					-40°C to 85°C			25	
					-40°C to 125°C			25	

### 5.8 Timing Characteristics $V_{CC} = 5 \text{ V} \pm 0.5 \text{ V}$

PARAMETER		FROM (INPUT)	TO (OUTPUT)	CONDITIONS	$T_A$	MIN	TYP	MAX	UNIT
$t_{PLH}$ $t_{PHL}$	Propagation delay time	COM or Yn	Yn or COM	$C_L = 15 \text{ pF}$	25°C		0.6	4	ns
					-40°C to 85°C			7	
					-40°C to 125°C			10	
$t_{PZH}$ $t_{PZL}$	Enable delay time	INH	COM or Yn	$C_L = 15 \text{ pF}$	25°C		3.5	8	ns
					-40°C to 85°C			10	
					-40°C to 125°C			12	
$t_{PHZ}$ $t_{PLZ}$	Disable delay time	INH	COM or Yn	$C_L = 15 \text{ pF}$	25°C		4.4	10	ns
					-40°C to 85°C			11	
					-40°C to 125°C			12	
$t_{PLH}$ $t_{PHL}$	Propagation delay time	COM or Yn	Yn or COM	$C_L = 50 \text{ pF}$	25°C		1.5	6	ns
					-40°C to 85°C			8	
					-40°C to 125°C			10	
$t_{PZH}$ $t_{PZL}$	Enable delay time	INH	COM or Yn	$C_L = 50 \text{ pF}$	25°C		4	14	ns
					-40°C to 85°C			18	
					-40°C to 125°C			18	
$t_{PHZ}$ $t_{PLZ}$	Disable delay time	INH	COM or Yn	$C_L = 50 \text{ pF}$	25°C		6.2	14	ns
					-40°C to 85°C			18	
					-40°C to 125°C			18	

### 5.9 AC Characteristics

PARAMETER	FROM (INPUT)	TO (OUTPUT)	Device	CONDITIONS	MIN	TYP	MAX	UNIT
Frequency response (switch on)	COM or Yn	Yn or COM	SN74LV4052	$C_L = 50 \text{ pF}$ , $R_L = 600 \text{ } \Omega$ , $F_{in} = 1 \text{ MHz}$ (sine wave) see Figure 7)(1)	$V_{CC} = 2.3 \text{ V}$		30	MHz
					$V_{CC} = 3 \text{ V}$		35	
					$V_{CC} = 4.5 \text{ V}$		50	
Charge Injection (control input to signal output)	INH	COM or Yn		$C_L = 50 \text{ pF}$ , $R_L = 600 \text{ } \Omega$ , $F_{in} = 1 \text{ MHz}$ (sine wave) (see Figure 9)	$V_{CC} = 2.3 \text{ V}$		20	mV
					$V_{CC} = 3 \text{ V}$		35	
					$V_{CC} = 4.5 \text{ V}$		60	

### 5.9 AC Characteristics (continued)

PARAMETER	FROM (INPUT)	TO (OUTPUT)	Device	CONDITIONS	MIN	TYP	MAX	UNIT
Feedthrough attenuation (switch off)	COM or Yn	Yn or COM		C <sub>L</sub> = 50 pF, R <sub>L</sub> = 600 Ω, F <sub>in</sub> = 1 MHz (sine wave) (see Figure 10) (2)	V <sub>CC</sub> = 2.3 V	-45		dB
					V <sub>CC</sub> = 3 V	-45		
					V <sub>CC</sub> = 4.5 V	-45		
Crosstalk (between any switches)	COM or Yn	Yn or COM		C <sub>L</sub> = 50 pF, R <sub>L</sub> = 600 Ω, F <sub>in</sub> = 1 MHz (sine wave) (see Figure 8)(2)	V <sub>CC</sub> = 2.3 V	-45		dB
					V <sub>CC</sub> = 3 V	-45		
					V <sub>CC</sub> = 4.5 V	-45		
Sine-wave distortion	COM or Yn	Yn or COM		C <sub>L</sub> = 50 pF, R <sub>L</sub> = 10 kΩ, F <sub>in</sub> = 1 kHz (sine wave) (see Figure 11)	V <sub>I</sub> = 2 V <sub>p-p</sub> , V <sub>CC</sub> = 2.3 V	0.1		%
					V <sub>I</sub> = 2.5 V <sub>p-p</sub> , V <sub>CC</sub> = 3 V	0.1		
					V <sub>I</sub> = 4 V <sub>p-p</sub> , V <sub>CC</sub> = 4.5 V	0.1		

### 5.10 Typical Characteristics

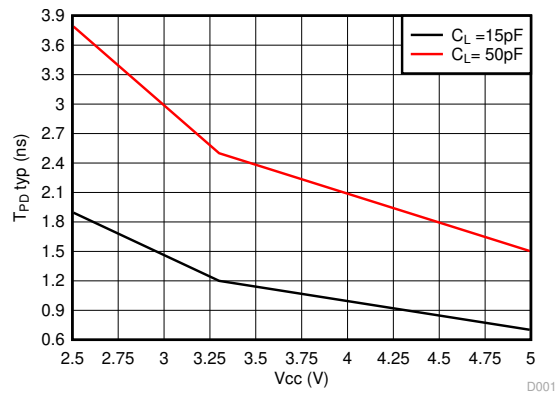

Figure 5-1. Typical Propagation Delay vs V<sub>CC</sub>

## 6 Parameter Measurement Information

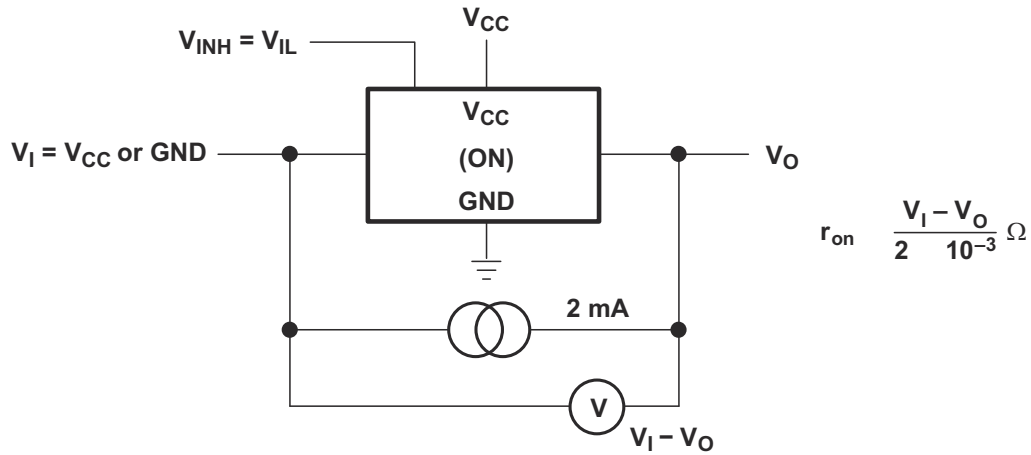

Figure 6-1. ON-State Resistance Test Circuit

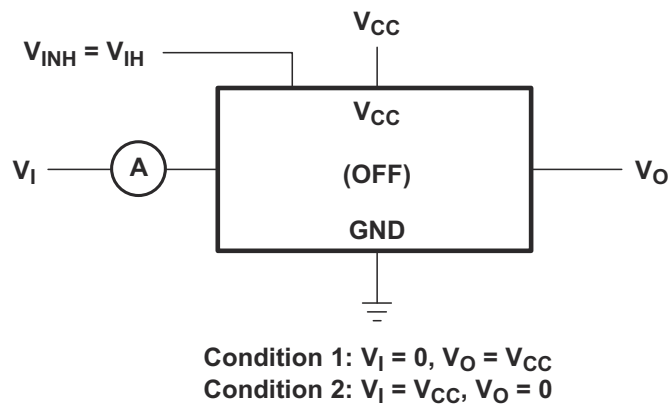

Figure 6-2. OFF-State Switch Leakage-Current Test Circuit

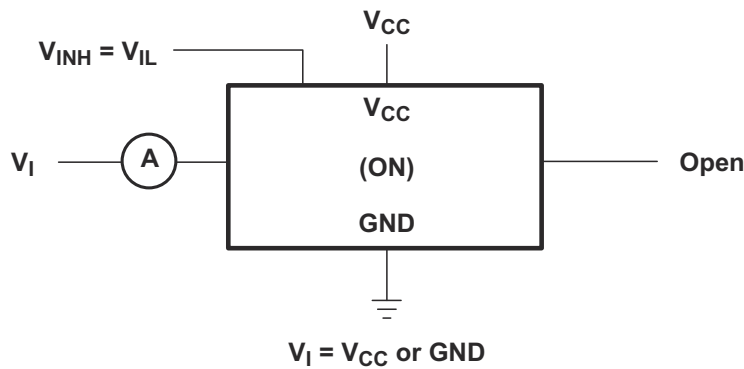

Figure 6-3. ON-State Switch Leakage-Current Test Circuit

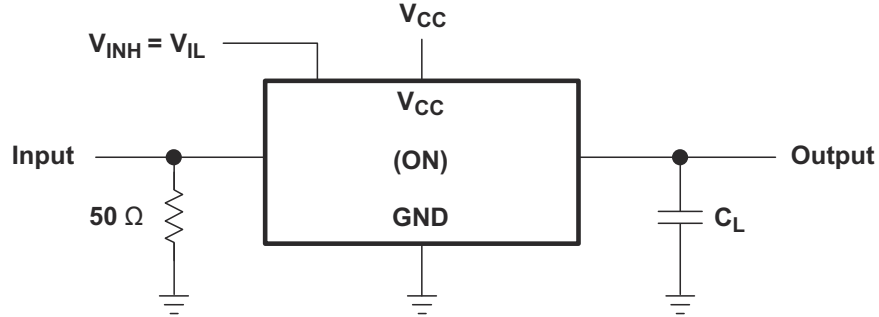
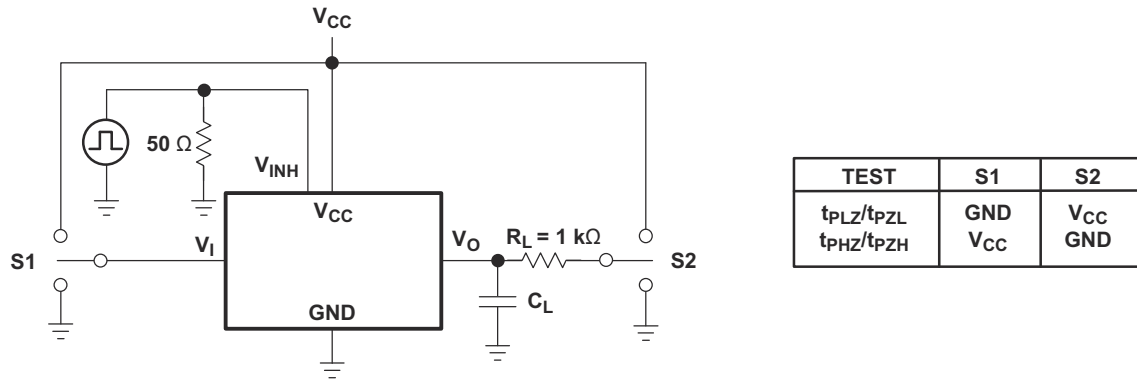

Figure 6-4. Propagation Delay Time, Signal Input to Signal Output



TEST	S1	S2
$t_{PLZ}/t_{PZL}$	GND	$V_{CC}$
$t_{PHZ}/t_{PHZ}$	$V_{CC}$	GND

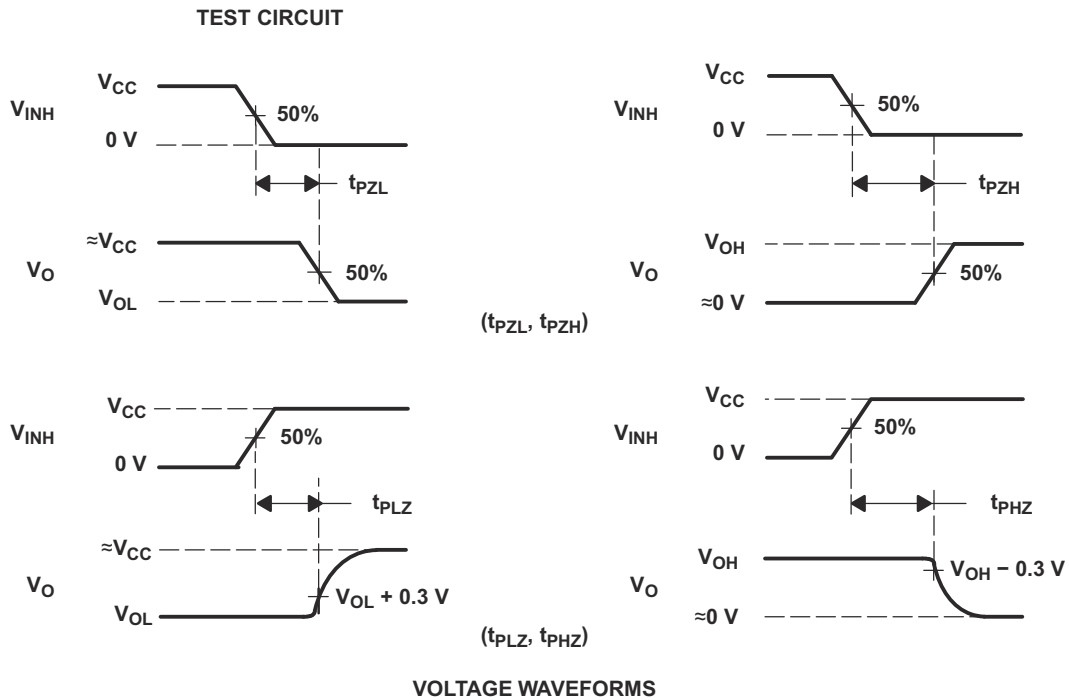
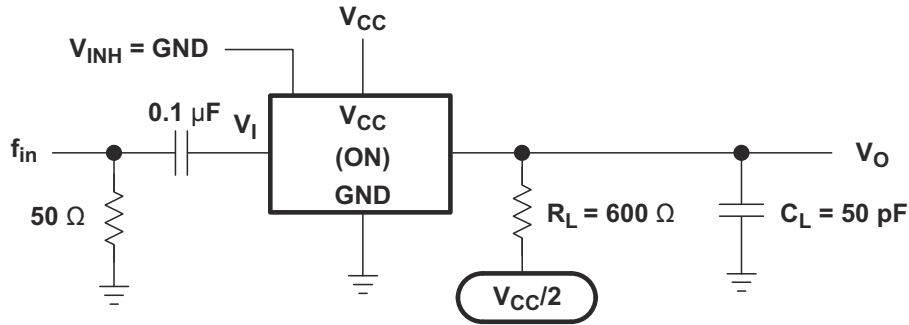

Figure 6-5. Switching Time ( $t_{PZL}$ ,  $t_{PLZ}$ ,  $t_{PHZ}$ ,  $t_{PHZ}$ ), Control to Signal Output



NOTE A:  $f_{in}$  is a sine wave.

Figure 6-6. Frequency Response (Switch ON)

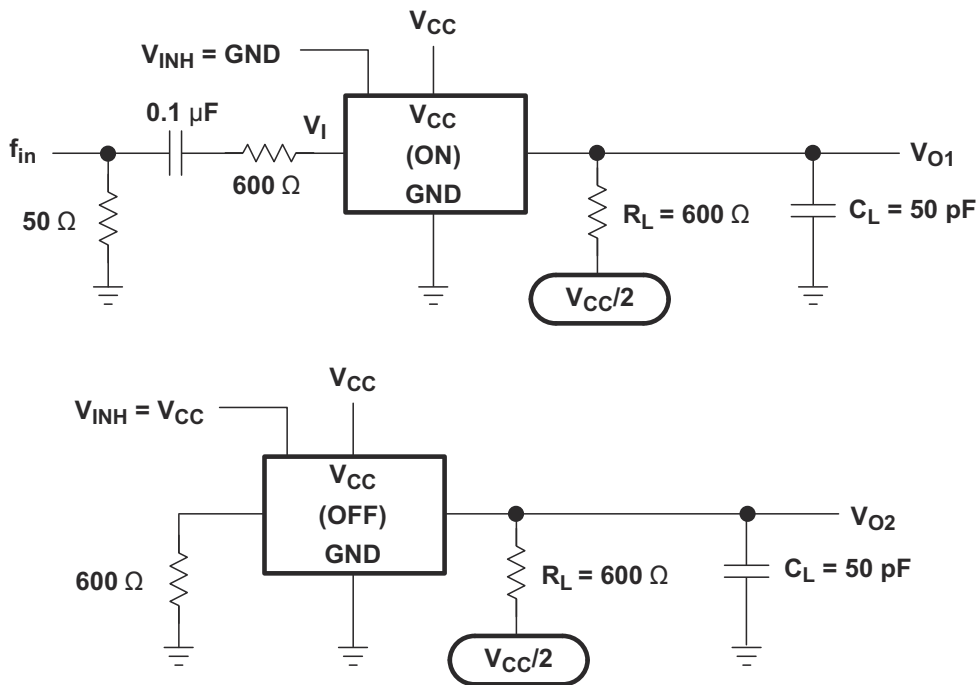

Figure 6-7. Crosstalk Between Any Two Switches

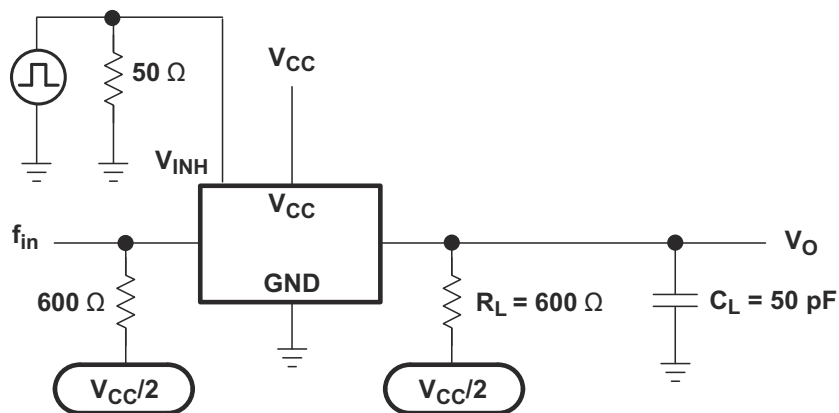
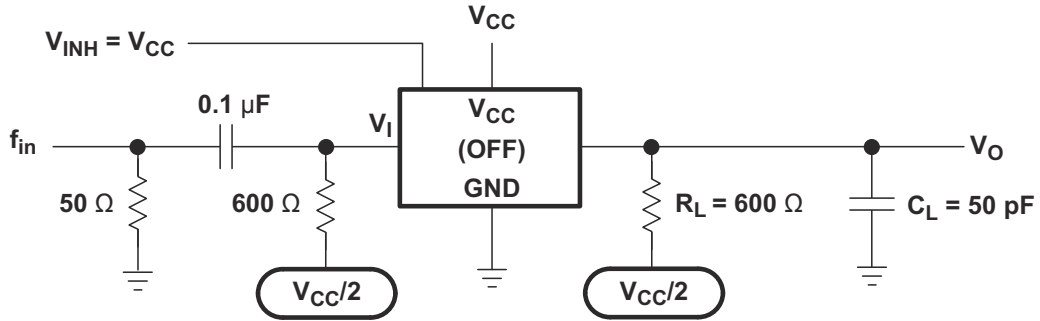
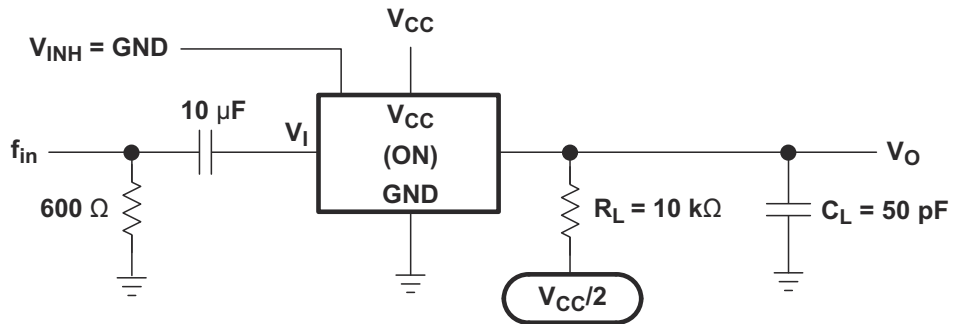

Figure 6-8. Crosstalk Between Control Input and Switch Output



**Figure 6-9. Feedthrough Attenuation (Switch OFF)**



**Figure 6-10. Sine-Wave Distortion**

## 7 Detailed Description

### 7.1 Overview

The SNx4LV4052A device is a dual, 4-channel CMOS analog multiplexer and demultiplexer that is designed for 2V to 5.5V  $V_{CC}$  operation. It has low input current consumption at the digital input pins and low crosstalk between switches. The active low Inhibit (INH) tri-state all the channels when high and when low, depending on the A and B inputs, one of the four independent input/outputs (nY0 - nY3) connects to the COM channel. The SNx4LV4052A is available in multiple package options including TSSOP (PW), SOIC (D), DYY (SOT-23-THIN) and QFN (RGY).

### 7.2 Functional Block Diagram

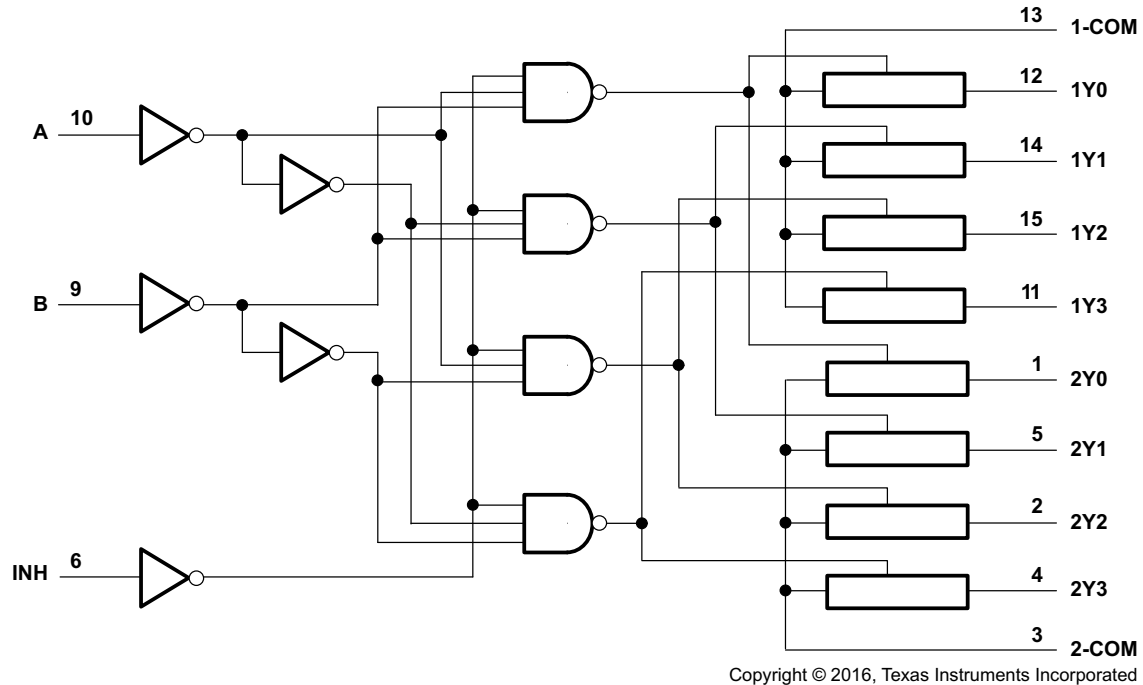

Figure 7-1. Logic Diagram (Positive Logic)

### 7.3 Feature Description

- The SNx4LV4052A operates from 2V to 5.5V  $V_{CC}$  with extremely low input current consumption at the CMOS input pins of A, B and INH.
- The SNx4LV4052A enables fast switching with low crosstalk between the switches. 5.5V peak level bidirectional transmission allowed with the either analog or digital signals.

### 7.4 Device Functional Modes

Table 7-1 lists the functional modes of SNx4LV4052A.

Table 7-1. Function Table

INPUTS			ON CHANNELS
INH	B	A	
L	L	L	1Y0, 2Y0
L	L	H	1Y1, 2Y1
L	H	L	1Y2, 2Y2
L	H	H	1Y3, 2Y3
H	X	X	None

## 8 Application and Implementation

### Note

Information in the following applications sections is not part of the TI component specification, and TI does not warrant its accuracy or completeness. TI's customers are responsible for determining suitability of components for their purposes, as well as validating and testing their design implementation to confirm system functionality.

### 8.1 Application Information

Typical applications for the SNx4LV4052A include signal gating, chopping, modulation or demodulation (modem), and signal multiplexing for analog-to-digital and digital-to-analog conversion systems.

### 8.2 Typical Application

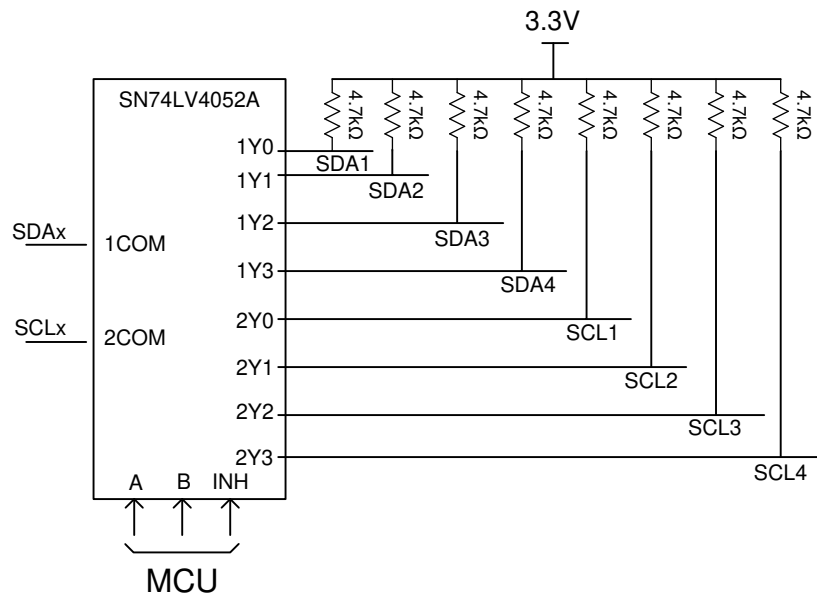

Copyright © 2016, Texas Instruments Incorporated

**Figure 8-1. Typical I<sup>2</sup>C Multiplexing Application**

#### 8.2.1 Design Requirements

Designing with the SNx4LV4052A device requires a stable input voltage between 2V and 5.5V (see *Recommended Operating Conditions* for details). Another important design consideration are the characteristics of the signal being multiplexed—ensure no important information is lost due to timing or incompatibility with this device.

#### 8.2.2 Detailed Design Procedure

The SNx4LV4052A dual 1- to 4-channel multiplexer is an excellent choice for I<sup>2</sup>C selection. The I<sup>2</sup>C data and clock lines are selected using A,B select lines from the MCU. The pullup resistors are selected based on the capability of the driver. Low pullup resistor results in faster rise time; however, it generates additional current during the low state into the driver. See the *Recommended Operating Conditions* for the input transition rates ( $V_{IH}$  and  $V_{IL}$ ) of the CMOS inputs.

### 8.2.3 Application Curve

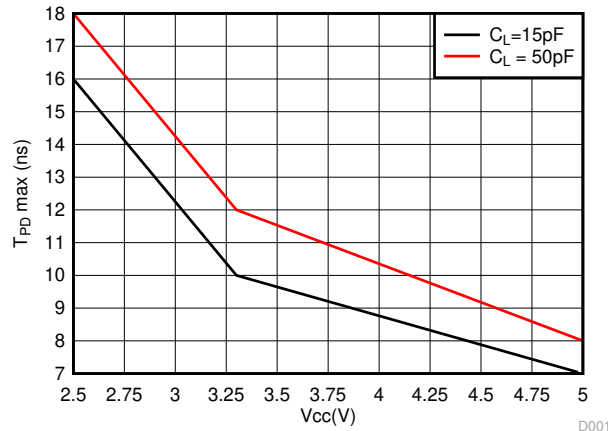

Figure 8-2. Maximum Propagation Delay vs V<sub>CC</sub> D001

### 8.3 Power Supply Recommendations

Most systems have a common 3.3V or 5V rail that can supply the V<sub>CC</sub> pin of this device. If this rail is not available, a switched-mode power supply (SMPS) or a low dropout regulator (LDO) can supply this device from a higher-voltage rail.

See the *Recommended Operating Conditions* for operating voltage range for this device. Having bypass capacitors of 0.1μF is highly recommended.

### 8.4 Layout

#### 8.4.1 Layout Guidelines

TI recommends keeping the signal lines as short and as straight as possible (see [Figure 8-3](#)). Incorporation of microstrip or stripline techniques are also recommended when signal lines are more than 1 in. long. These traces must be designed with a characteristic impedance of either 50Ω or 75Ω as required by the application.

Do not place this device too close to high-voltage switching components because they may cause interference. Not all PCB traces can be straight and therefore some traces must turn corners. [Figure 8-4](#) shows progressively better techniques of rounding corners. Only the last example (BEST) maintains constant trace width and minimizes reflections.

### 8.4.2 Layout Example

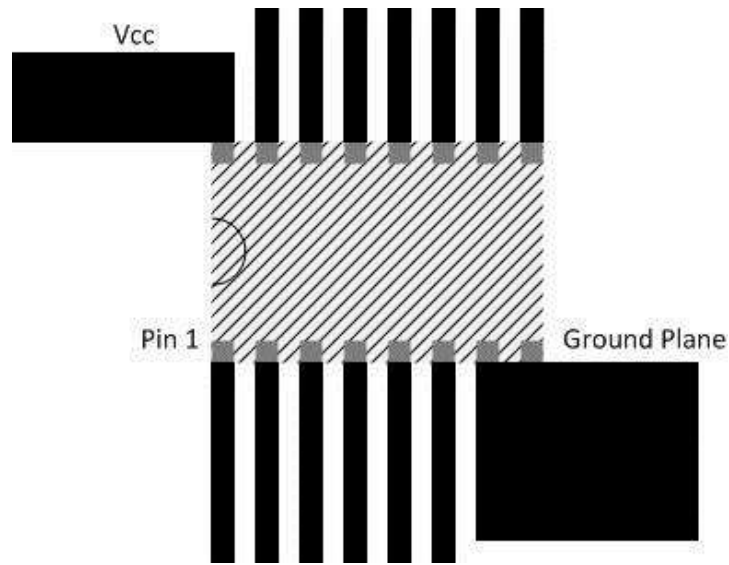

Figure 8-3. Layout Schematic

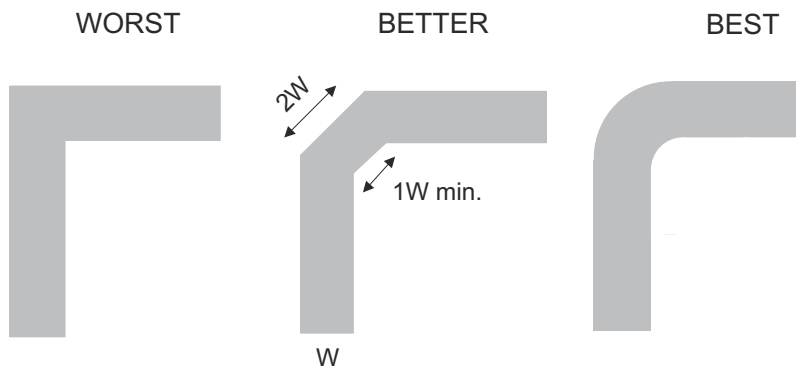

Figure 8-4. Trace Example

## 9 Device and Documentation Support

### 9.1 Documentation Support

#### 9.1.1 Related Documentation

For related documentation, see the following:

- Texas Instruments, [Implications of Slow or Floating CMOS Inputs](#)

### 9.2 Receiving Notification of Documentation Updates

To receive notification of documentation updates, navigate to the device product folder on ti.com. In the upper right corner, click on *Alert me* to register and receive a weekly digest of any product information that has changed. For change details, review the revision history included in any revised document.

### 9.3 Support Resources

TI E2E™ support forums are an engineer's go-to source for fast, verified answers and design help — straight from the experts. Search existing answers or ask your own question to get the quick design help you need.

Linked content is provided "AS IS" by the respective contributors. They do not constitute TI specifications and do not necessarily reflect TI's views; see TI's [Terms of Use](#).

### 9.4 Trademarks

TI E2E™ is a trademark of Texas Instruments.

All trademarks are the property of their respective owners.

### 9.5 Electrostatic Discharge Caution



This integrated circuit can be damaged by ESD. Texas Instruments recommends that all integrated circuits be handled with appropriate precautions. Failure to observe proper handling and installation procedures can cause damage.

ESD damage can range from subtle performance degradation to complete device failure. Precision integrated circuits may be more susceptible to damage because very small parametric changes could cause the device not to meet its published specifications.

### 9.6 Glossary

[TI Glossary](#) This glossary lists and explains terms, acronyms, and definitions.

## 10 Revision History

NOTE: Page numbers for previous revisions may differ from page numbers in the current version.

Changes from Revision M (September 2024) to Revision N (September 2024)	Page
• Added DYY package and size.....	1
• Added DYY package.....	3
• Added DYY package.....	4
• Added DYY package.....	4

Changes from Revision L (June 2024) to Revision M (September 2024)	Page
• Updated ESD Ratings CDM from +/-1500V to +/-2000V.....	4

Changes from Revision K (November 2016) to Revision L (June 2024)	Page
• Updated the numbering format for tables, figures, and cross-references throughout the document.....	1
• Added new VIH and VIL Specifications at 1.65V Vcc.....	5
• Increased max ambient temperature max to 125C.....	5
• Added Ron, Ron Peak, and Delta Ron Specifications at 1.65V Vcc.....	5

---

- Added Ron, Ron Peak, and Delta Ron Specifications at 125C.....5
- Added Timing Specifications at 125C.....7

---

## 11 Mechanical, Packaging, and Orderable Information

The following pages include mechanical, packaging, and orderable information. This information is the most current data available for the designated devices. This data is subject to change without notice and revision of this document. For browser-based versions of this data sheet, refer to the left-hand navigation.

**PACKAGING INFORMATION**

Orderable Device	Status (1)	Package Type	Package Drawing	Pins	Package Qty	Eco Plan (2)	Lead finish/ Ball material (6)	MSL Peak Temp (3)	Op Temp (°C)	Device Marking (4/5)	Samples
SN74LV4052ADBR	NRND	SSOP	DB	16	2000	RoHS & Green	NIPDAU	Level-1-260C-UNLIM	-40 to 85	LW052A	
SN74LV4052ADBRE4	NRND	SSOP	DB	16	2000	RoHS & Green	NIPDAU	Level-1-260C-UNLIM	-40 to 85	LW052A	
SN74LV4052ADGVR	NRND	TVSOP	DGV	16	2000	RoHS & Green	NIPDAU	Level-1-260C-UNLIM	-40 to 85	LW052A	
SN74LV4052ADR	ACTIVE	SOIC	D	16	2500	RoHS & Green	NIPDAU	Level-1-260C-UNLIM	-40 to 85	LV4052A	Samples
SN74LV4052ADYYR	ACTIVE	SOT-23-THIN	DYY	16	3000	RoHS & Green	NIPDAU	Level-1-260C-UNLIM	-40 to 85	LV4052	Samples
SN74LV4052AN	NRND	PDIP	N	16	25	RoHS & Green	NIPDAU	N / A for Pkg Type	-40 to 85	SN74LV4052AN	
SN74LV4052ANSR	NRND	SOP	NS	16	2000	RoHS & Green	NIPDAU	Level-1-260C-UNLIM	-40 to 85	74LV4052A	
SN74LV4052APWR	ACTIVE	TSSOP	PW	16	2000	RoHS & Green	NIPDAU	Level-1-260C-UNLIM	-40 to 85	LW052A	Samples
SN74LV4052APWRG4	OBSOLETE	TSSOP	PW	16		TBD	Call TI	Call TI	-40 to 85	LW052A	
SN74LV4052APWT	OBSOLETE	TSSOP	PW	16		TBD	Call TI	Call TI	-40 to 85	LW052A	
SN74LV4052ARGYR	ACTIVE	VQFN	RGY	16	3000	RoHS & Green	NIPDAU	Level-1-260C-UNLIM	-40 to 85	LW052A	Samples

(1) The marketing status values are defined as follows:

**ACTIVE:** Product device recommended for new designs.

**LIFEBUY:** TI has announced that the device will be discontinued, and a lifetime-buy period is in effect.

**NRND:** Not recommended for new designs. Device is in production to support existing customers, but TI does not recommend using this part in a new design.

**PREVIEW:** Device has been announced but is not in production. Samples may or may not be available.

**OBSOLETE:** TI has discontinued the production of the device.

(2) **RoHS:** TI defines "RoHS" to mean semiconductor products that are compliant with the current EU RoHS requirements for all 10 RoHS substances, including the requirement that RoHS substance do not exceed 0.1% by weight in homogeneous materials. Where designed to be soldered at high temperatures, "RoHS" products are suitable for use in specified lead-free processes. TI may reference these types of products as "Pb-Free".

**RoHS Exempt:** TI defines "RoHS Exempt" to mean products that contain lead but are compliant with EU RoHS pursuant to a specific EU RoHS exemption.

**Green:** TI defines "Green" to mean the content of Chlorine (Cl) and Bromine (Br) based flame retardants meet JS709B low halogen requirements of <=1000ppm threshold. Antimony trioxide based flame retardants must also meet the <=1000ppm threshold requirement.

(3) MSL, Peak Temp. - The Moisture Sensitivity Level rating according to the JEDEC industry standard classifications, and peak solder temperature.

(4) There may be additional marking, which relates to the logo, the lot trace code information, or the environmental category on the device.

(5) Multiple Device Markings will be inside parentheses. Only one Device Marking contained in parentheses and separated by a "~" will appear on a device. If a line is indented then it is a continuation of the previous line and the two combined represent the entire Device Marking for that device.

(6) Lead finish/Ball material - Orderable Devices may have multiple material finish options. Finish options are separated by a vertical ruled line. Lead finish/Ball material values may wrap to two lines if the finish value exceeds the maximum column width.

**Important Information and Disclaimer:**The information provided on this page represents TI's knowledge and belief as of the date that it is provided. TI bases its knowledge and belief on information provided by third parties, and makes no representation or warranty as to the accuracy of such information. Efforts are underway to better integrate information from third parties. TI has taken and continues to take reasonable steps to provide representative and accurate information but may not have conducted destructive testing or chemical analysis on incoming materials and chemicals. TI and TI suppliers consider certain information to be proprietary, and thus CAS numbers and other limited information may not be available for release.

In no event shall TI's liability arising out of such information exceed the total purchase price of the TI part(s) at issue in this document sold by TI to Customer on an annual basis.

**OTHER QUALIFIED VERSIONS OF SN74LV4052A :**

- Automotive : [SN74LV4052A-Q1](#)
- Enhanced Product : [SN74LV4052A-EP](#)

NOTE: Qualified Version Definitions:

- Automotive - Q100 devices qualified for high-reliability automotive applications targeting zero defects
- Enhanced Product - Supports Defense, Aerospace and Medical Applications

DGV (R-PDSO-G\*\*)

PLASTIC SMALL-OUTLINE

24 PINS SHOWN

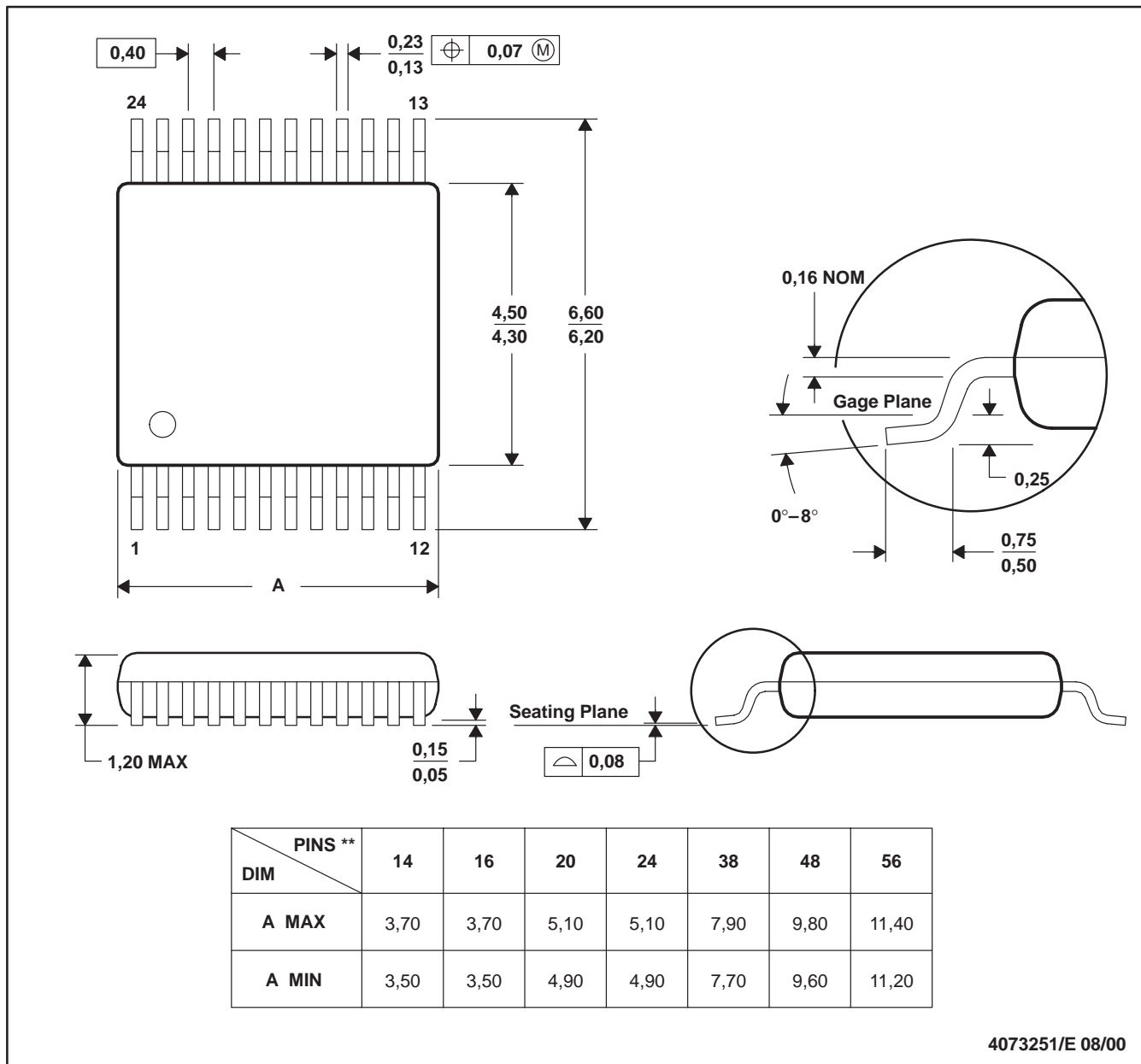

- NOTES: A. All linear dimensions are in millimeters.  
 B. This drawing is subject to change without notice.  
 C. Body dimensions do not include mold flash or protrusion, not to exceed 0,15 per side.  
 D. Falls within JEDEC: 24/48 Pins – MO-153  
 14/16/20/56 Pins – MO-194

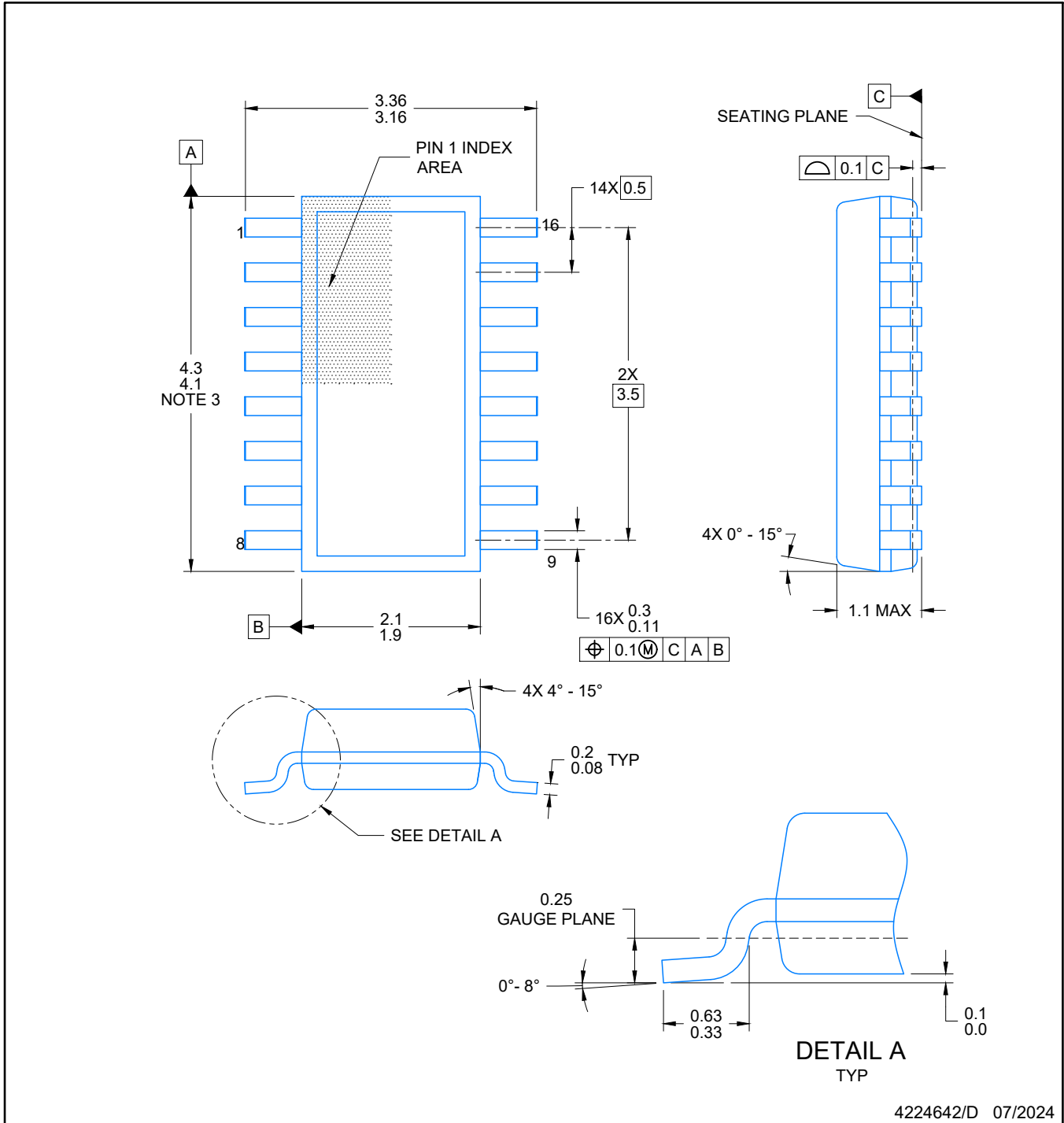

4224642/D 07/2024

NOTES:

1. All linear dimensions are in millimeters. Any dimensions in parenthesis are for reference only. Dimensioning and tolerancing per ASME Y14.5M.
2. This drawing is subject to change without notice.
3. This dimension does not include mold flash, protrusions, or gate burrs. Mold flash, protrusions, or gate burrs shall not exceed 0.15 per side.
4. This dimension does not include interlead flash. Interlead flash shall not exceed 0.50 per side.
5. Reference JEDEC Registration MO-345, Variation AA

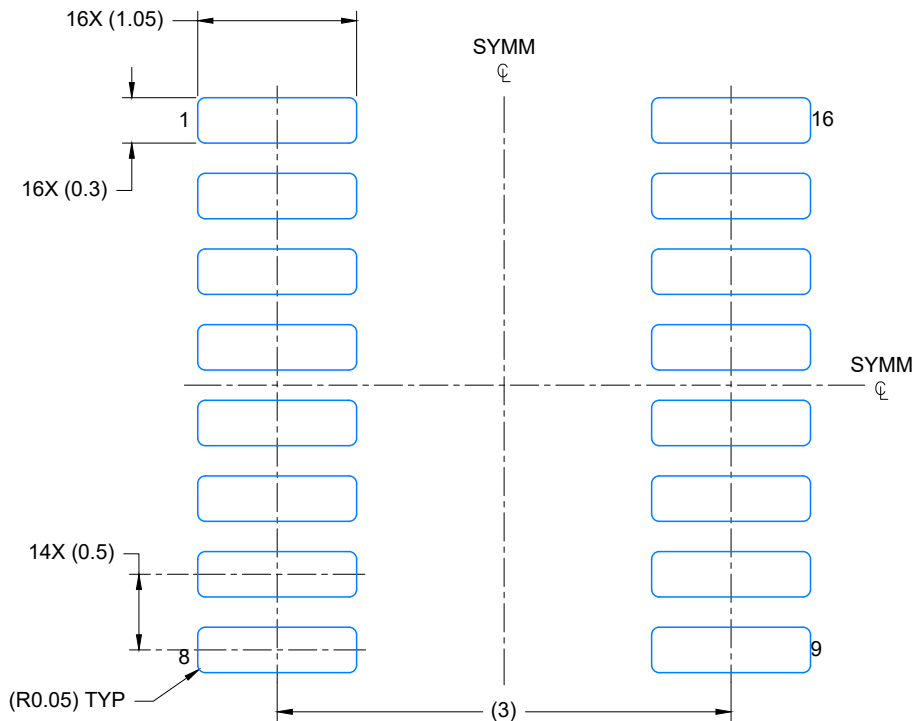

LAND PATTERN EXAMPLE  
EXPOSED METAL SHOWN  
SCALE: 20X

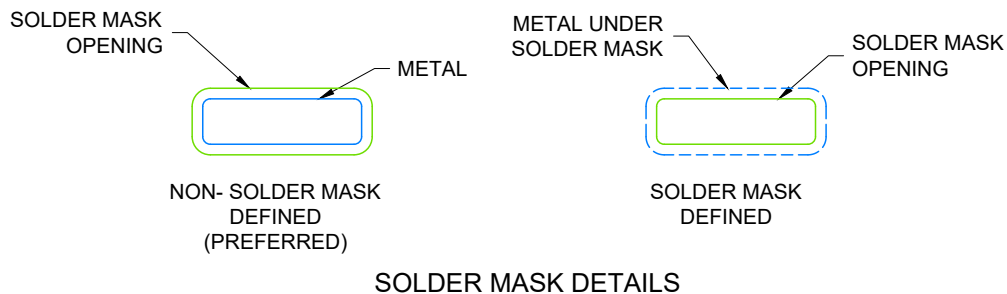

4224642/D 07/2024

NOTES: (continued)

- 6. Publication IPC-7351 may have alternate designs.
- 7. Solder mask tolerances between and around signal pads can vary based on board fabrication site.

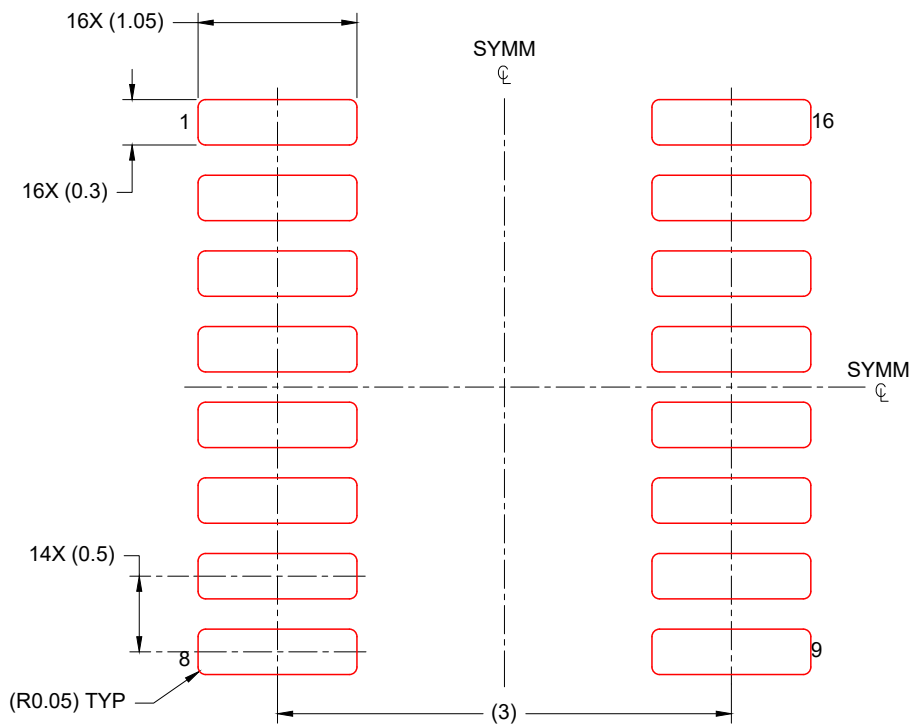

SOLDER PASTE EXAMPLE  
BASED ON 0.125 mm THICK STENCIL  
SCALE: 20X

4224642/D 07/2024

NOTES: (continued)

- 8. Laser cutting apertures with trapezoidal walls and rounded corners may offer better paste release. IPC-7525 may have alternate design recommendations.
- 9. Board assembly site may have different recommendations for stencil design.

N (R-PDIP-T\*\*)

PLASTIC DUAL-IN-LINE PACKAGE

16 PINS SHOWN

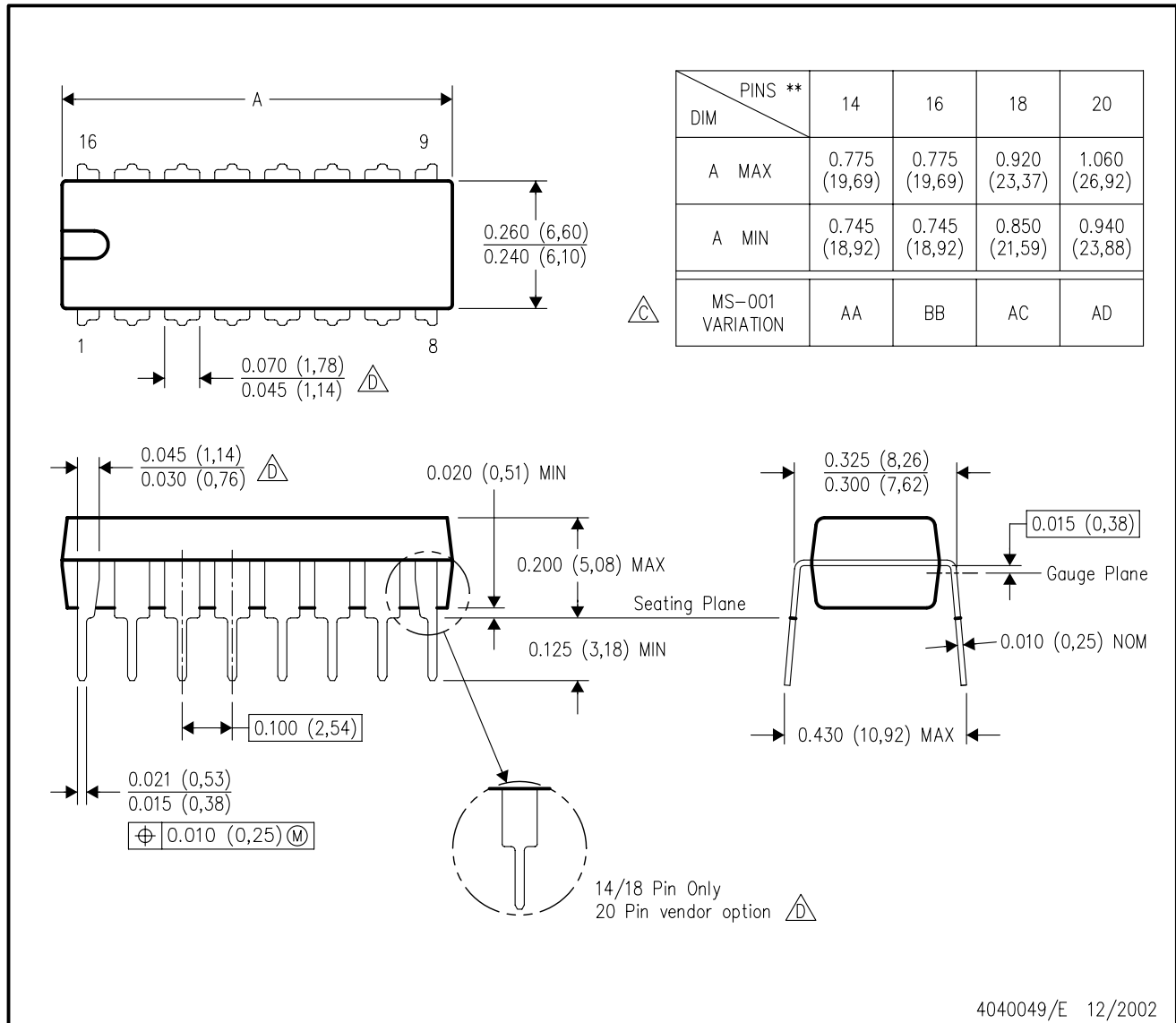

- NOTES:
- A. All linear dimensions are in inches (millimeters).
  - B. This drawing is subject to change without notice.
  - $\triangle C$  Falls within JEDEC MS-001, except 18 and 20 pin minimum body length (Dim A).
  - $\triangle D$  The 20 pin end lead shoulder width is a vendor option, either half or full width.

RGY (R-PVQFN-N16)

PLASTIC QUAD FLATPACK NO-LEAD

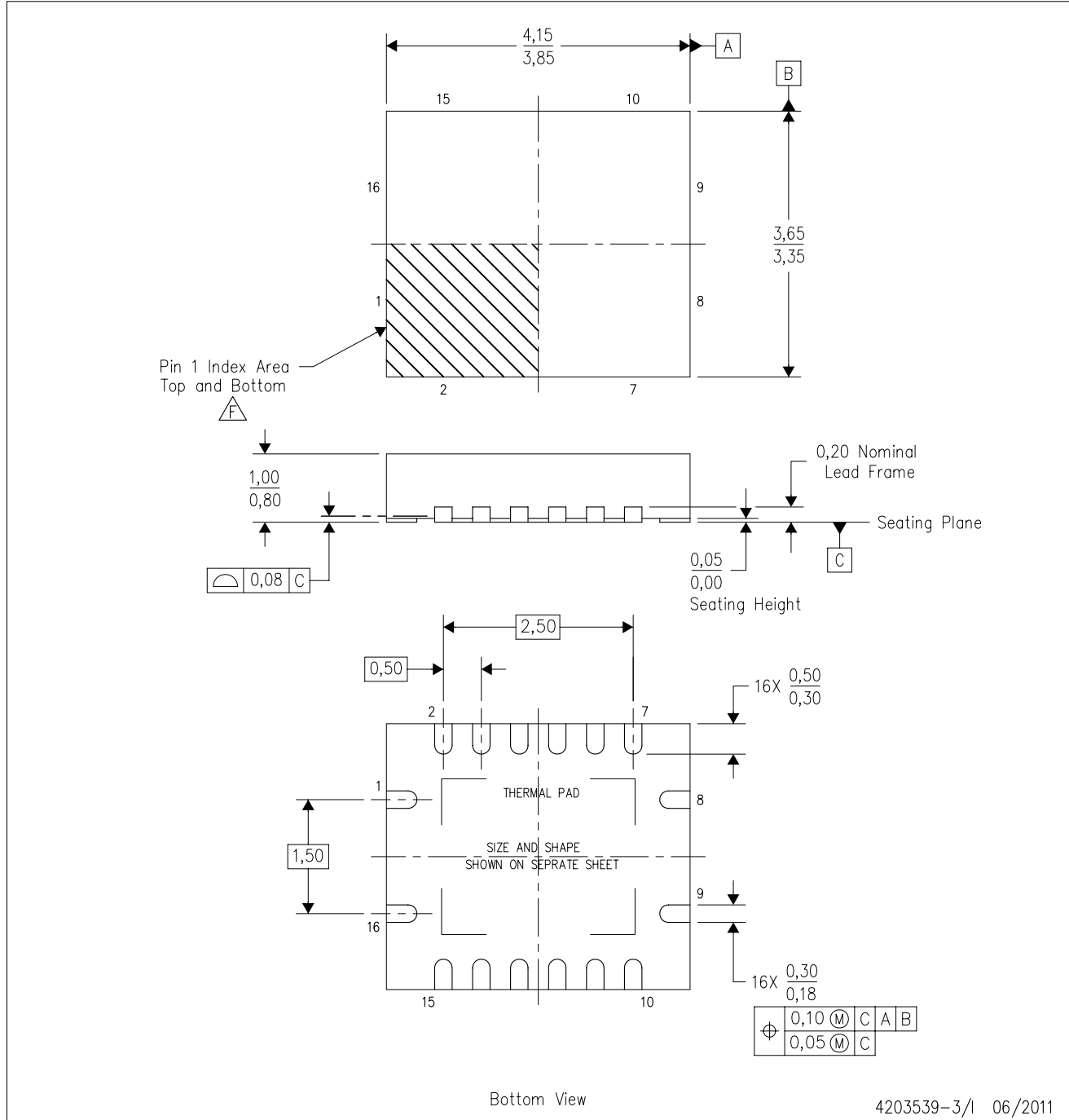

4203539-3/1 06/2011

- NOTES:
- All linear dimensions are in millimeters. Dimensioning and tolerancing per ASME Y14.5M-1994.
  - This drawing is subject to change without notice.
  - QFN (Quad Flatpack No-Lead) package configuration.
  - The package thermal pad must be soldered to the board for thermal and mechanical performance.
  - See the additional figure in the Product Data Sheet for details regarding the exposed thermal pad features and dimensions.
  - Pin 1 identifiers are located on both top and bottom of the package and within the zone indicated. The Pin 1 identifiers are either a molded, marked, or metal feature.
  - Package complies to JEDEC MO-241 variation BA.

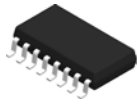

# PACKAGE OUTLINE

## NS0016A

### SOP - 2.00 mm max height

SOP

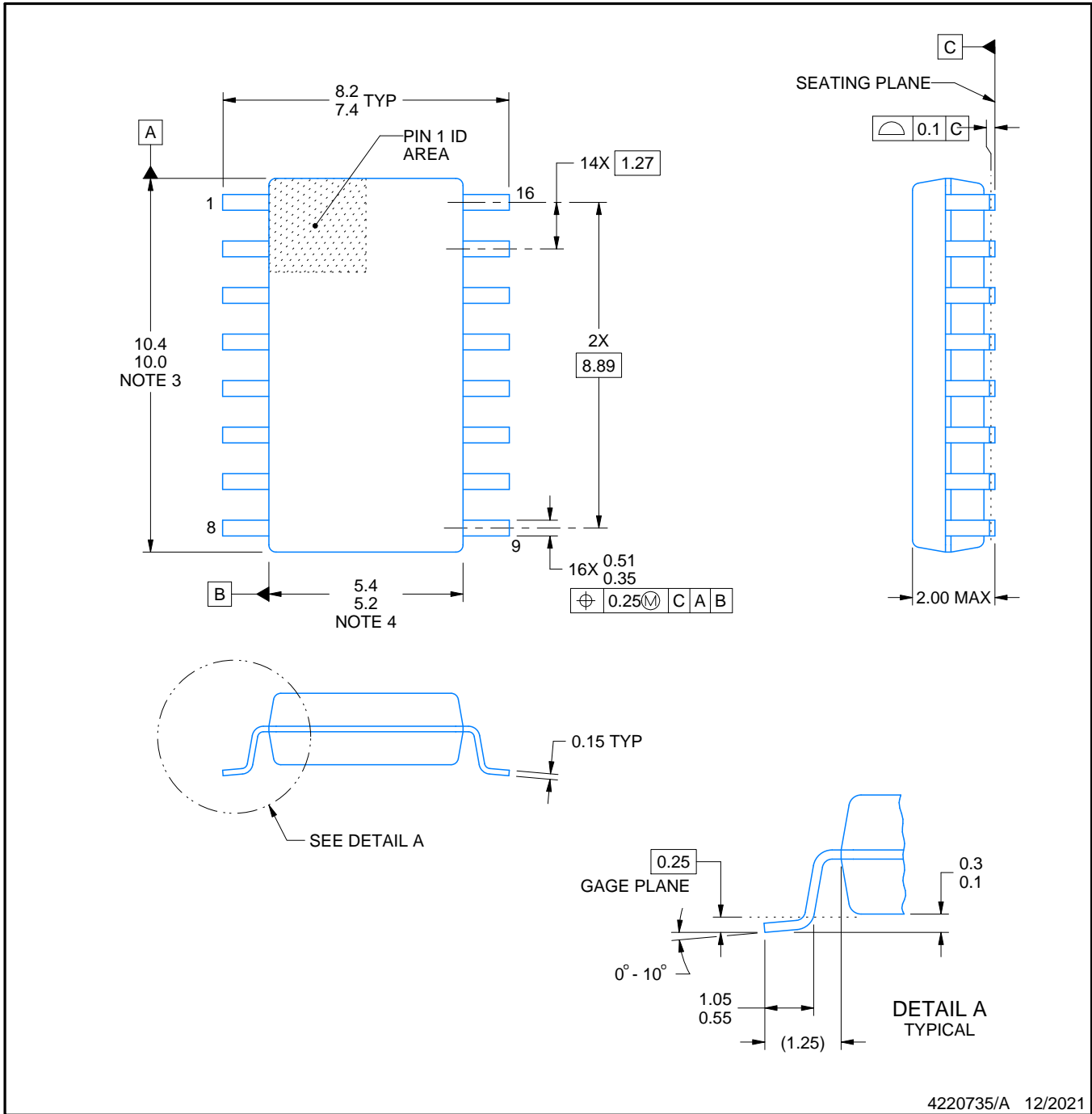

4220735/A 12/2021

#### NOTES:

1. All linear dimensions are in millimeters. Dimensions in parenthesis are for reference only. Dimensioning and tolerancing per ASME Y14.5M.
2. This drawing is subject to change without notice.
3. This dimension does not include mold flash, protrusions, or gate burrs. Mold flash, protrusions, or gate burrs shall not exceed 0.15 mm, per side.
4. This dimension does not include interlead flash. Interlead flash shall not exceed 0.25 mm, per side.

# EXAMPLE BOARD LAYOUT

NS0016A

SOP - 2.00 mm max height

SOP

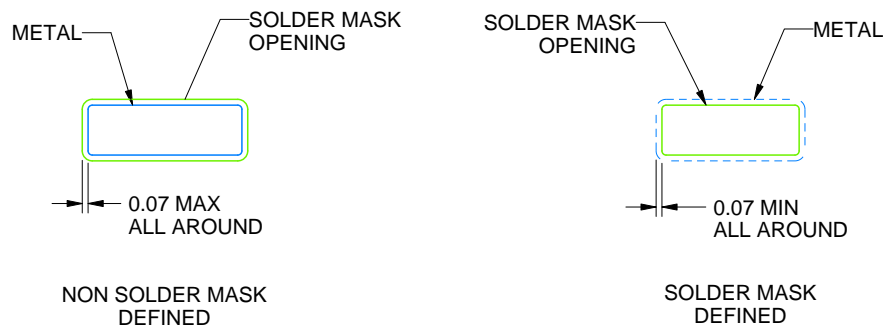
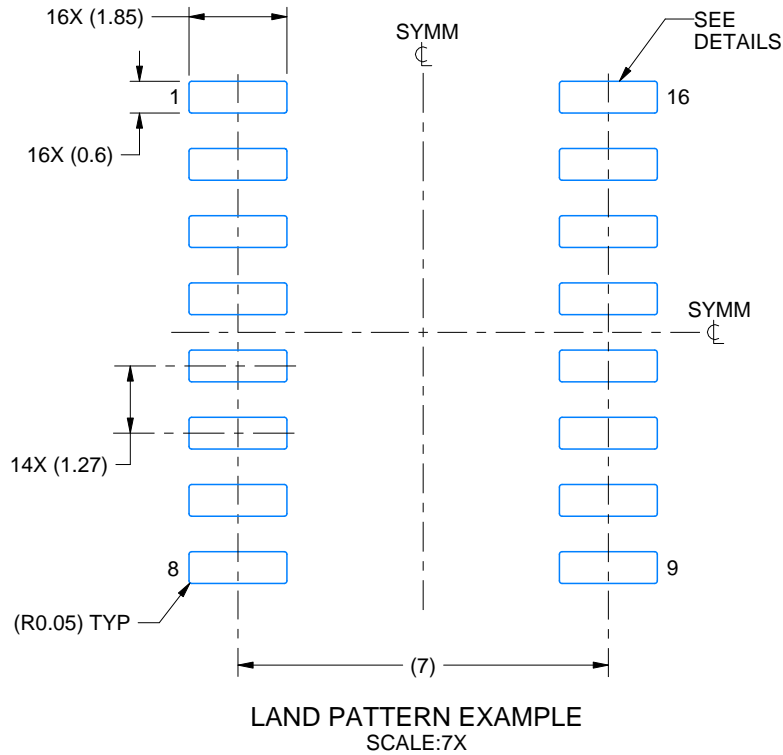

4220735/A 12/2021

NOTES: (continued)

5. Publication IPC-7351 may have alternate designs.

6. Solder mask tolerances between and around signal pads can vary based on board fabrication site.

# EXAMPLE STENCIL DESIGN

NS0016A

SOP - 2.00 mm max height

SOP

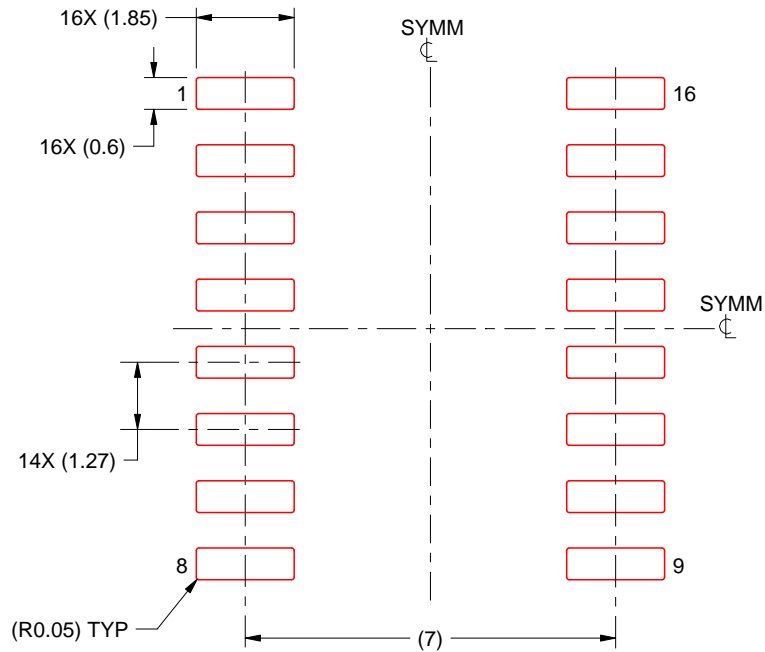

SOLDER PASTE EXAMPLE  
BASED ON 0.125 mm THICK STENCIL  
SCALE:7X

4220735/A 12/2021

NOTES: (continued)

7. Laser cutting apertures with trapezoidal walls and rounded corners may offer better paste release. IPC-7525 may have alternate design recommendations.
8. Board assembly site may have different recommendations for stencil design.

D (R-PDSO-G16)

PLASTIC SMALL OUTLINE

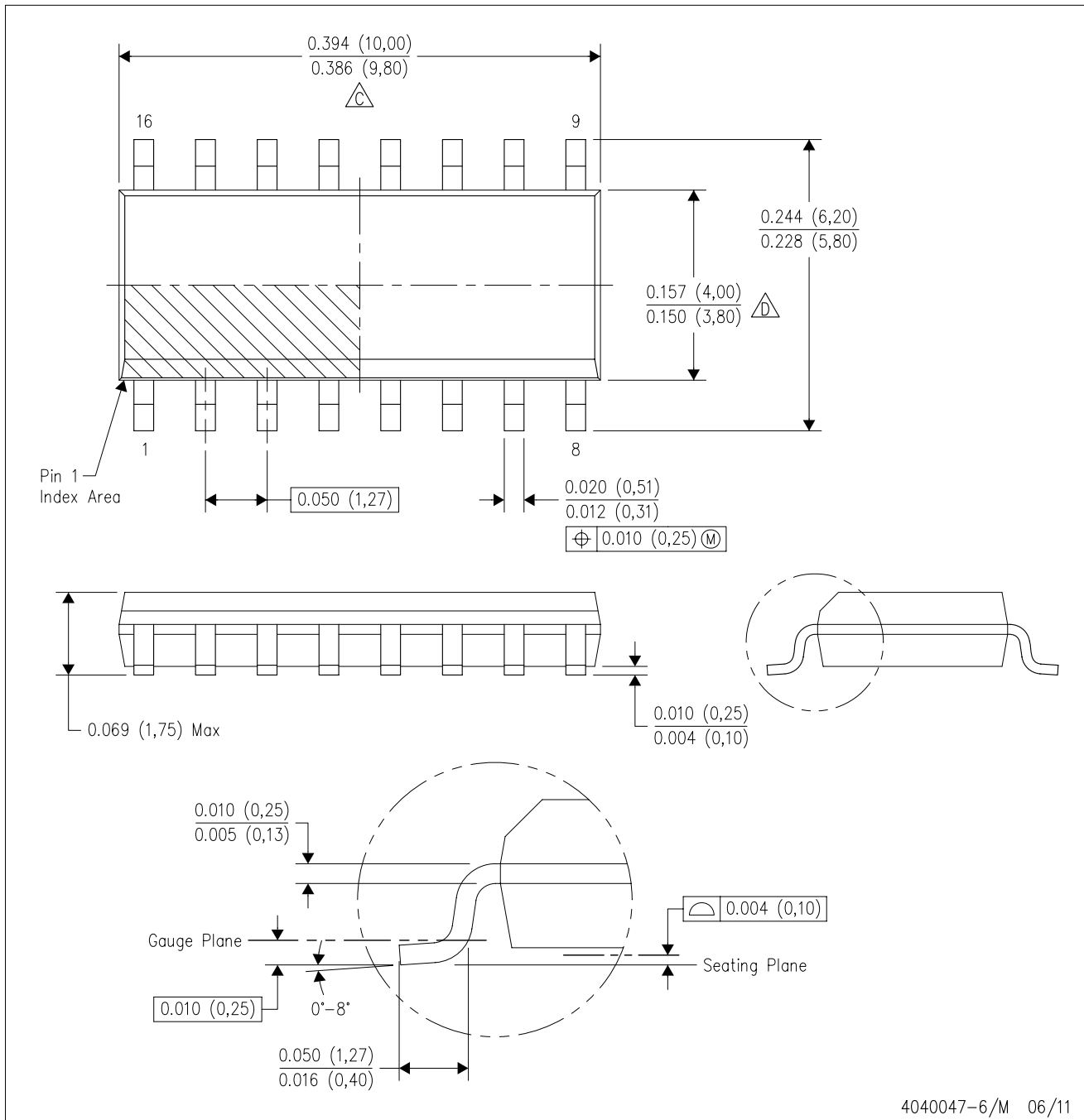

- NOTES:
- A. All linear dimensions are in inches (millimeters).
  - B. This drawing is subject to change without notice.
  - C. Body length does not include mold flash, protrusions, or gate burrs. Mold flash, protrusions, or gate burrs shall not exceed 0.006 (0,15) each side.
  - D. Body width does not include interlead flash. Interlead flash shall not exceed 0.017 (0,43) each side.
  - E. Reference JEDEC MS-012 variation AC.

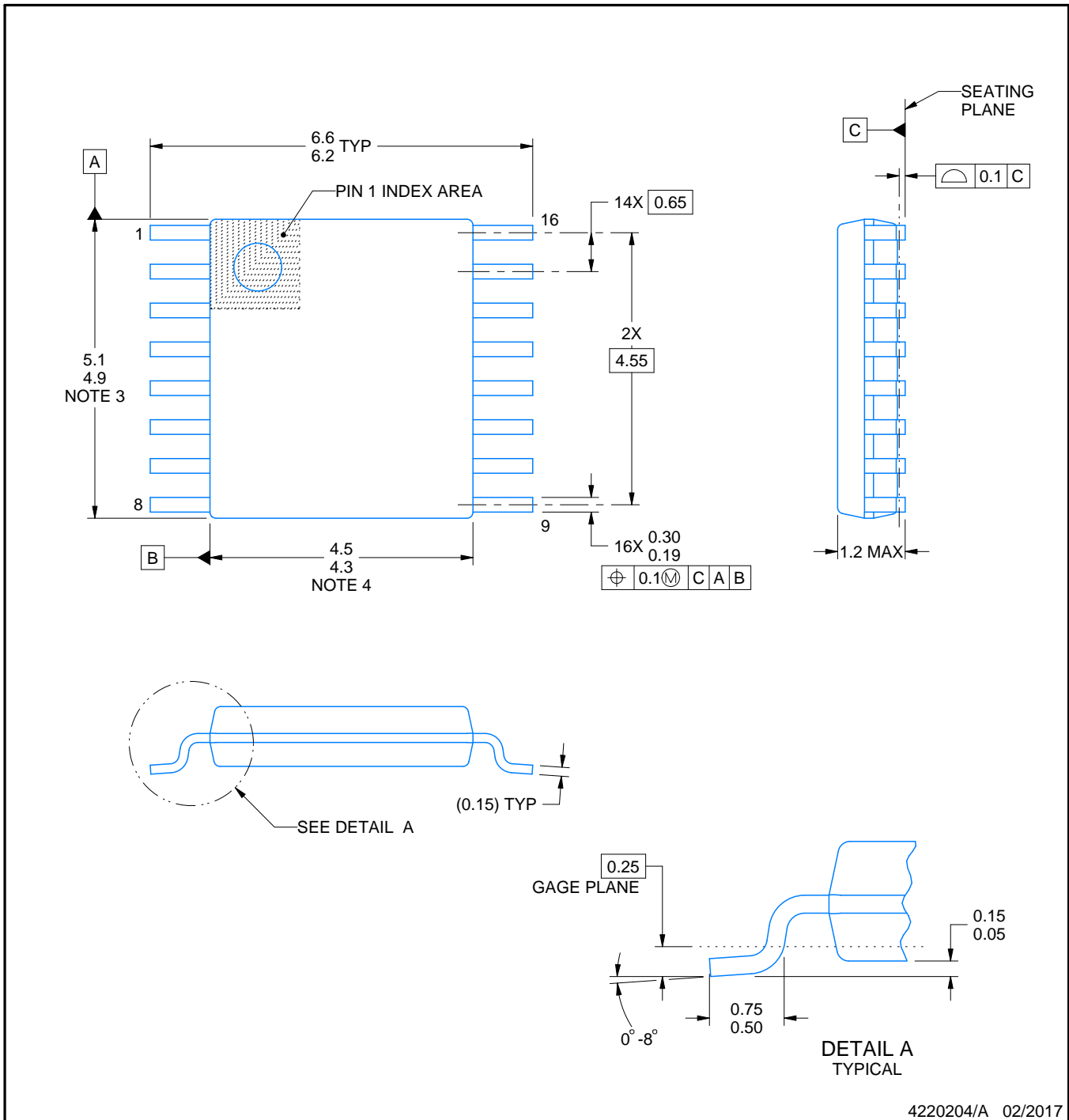

4220204/A 02/2017

NOTES:

1. All linear dimensions are in millimeters. Any dimensions in parenthesis are for reference only. Dimensioning and tolerancing per ASME Y14.5M.
2. This drawing is subject to change without notice.
3. This dimension does not include mold flash, protrusions, or gate burrs. Mold flash, protrusions, or gate burrs shall not exceed 0.15 mm per side.
4. This dimension does not include interlead flash. Interlead flash shall not exceed 0.25 mm per side.
5. Reference JEDEC registration MO-153.

# EXAMPLE BOARD LAYOUT

PW0016A

TSSOP - 1.2 mm max height

SMALL OUTLINE PACKAGE

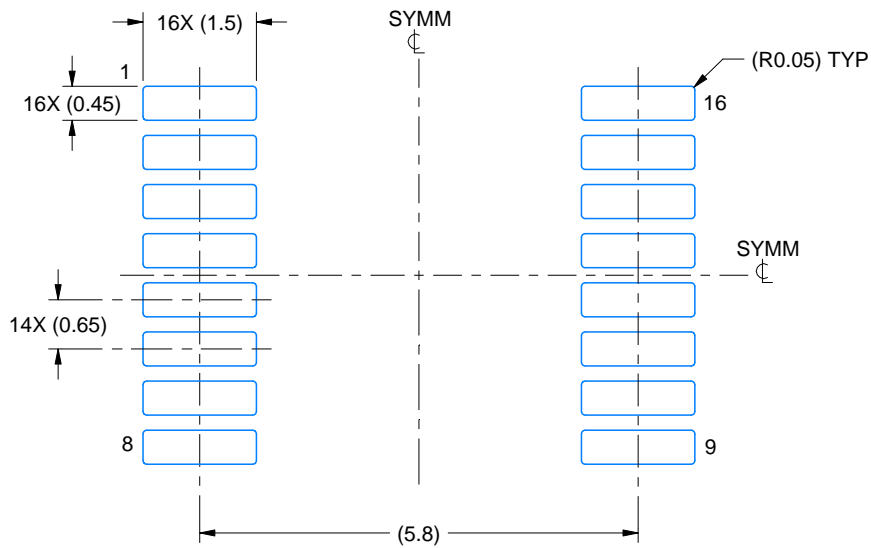

LAND PATTERN EXAMPLE  
EXPOSED METAL SHOWN  
SCALE: 10X

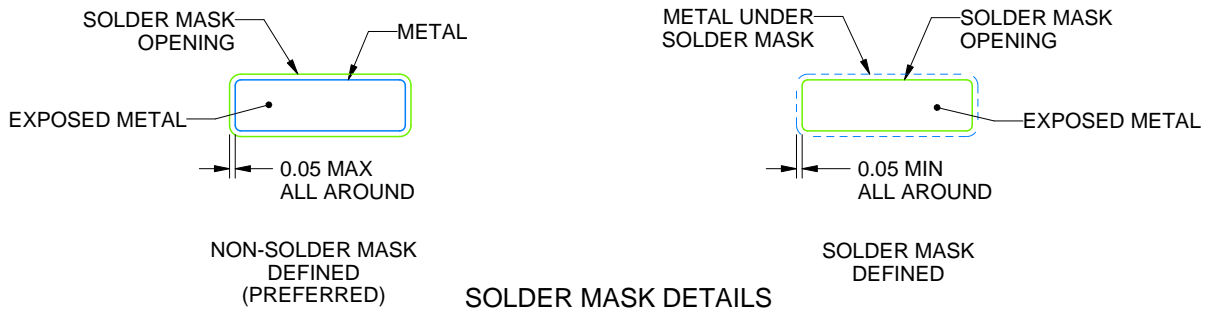

SOLDER MASK DETAILS

4220204/A 02/2017

NOTES: (continued)

- 6. Publication IPC-7351 may have alternate designs.
- 7. Solder mask tolerances between and around signal pads can vary based on board fabrication site.

# EXAMPLE STENCIL DESIGN

PW0016A

TSSOP - 1.2 mm max height

SMALL OUTLINE PACKAGE

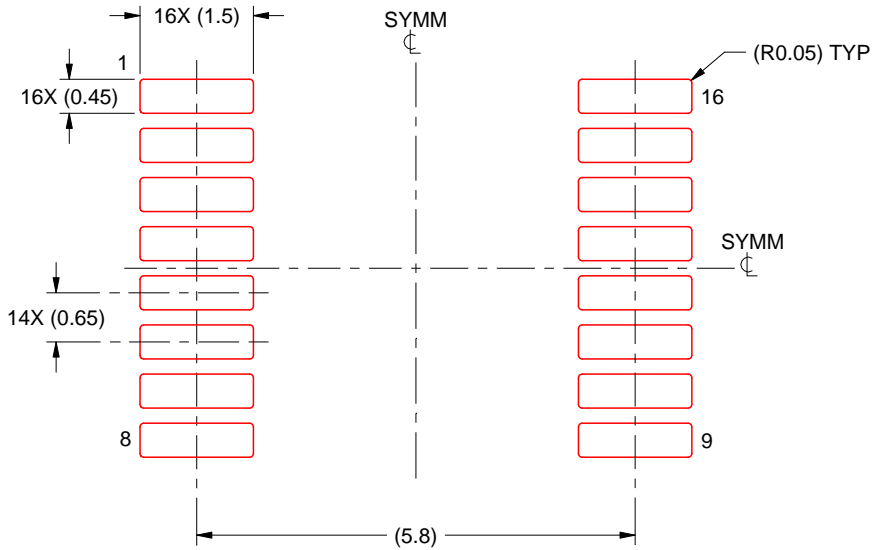

SOLDER PASTE EXAMPLE  
BASED ON 0.125 mm THICK STENCIL  
SCALE: 10X

4220204/A 02/2017

NOTES: (continued)

8. Laser cutting apertures with trapezoidal walls and rounded corners may offer better paste release. IPC-7525 may have alternate design recommendations.
9. Board assembly site may have different recommendations for stencil design.

# DB0016A



# PACKAGE OUTLINE

## SSOP - 2 mm max height

SMALL OUTLINE PACKAGE

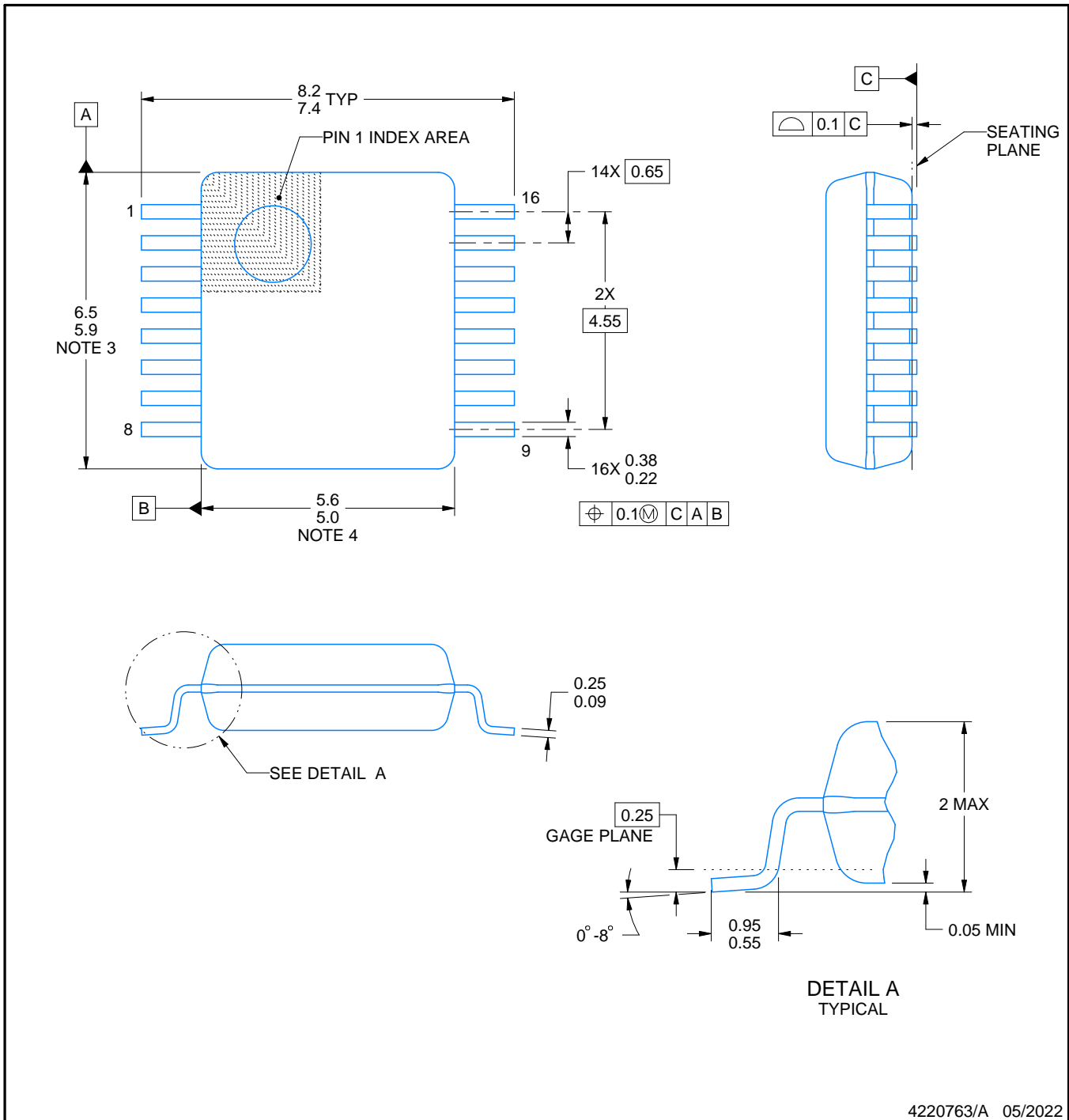

4220763/A 05/2022

### NOTES:

1. All linear dimensions are in millimeters. Any dimensions in parenthesis are for reference only. Dimensioning and tolerancing per ASME Y14.5M.
2. This drawing is subject to change without notice.
3. This dimension does not include mold flash, protrusions, or gate burrs. Mold flash, protrusions, or gate burrs shall not exceed 0.15 mm per side.
4. Reference JEDEC registration MO-150.

# EXAMPLE BOARD LAYOUT

DB0016A

SSOP - 2 mm max height

SMALL OUTLINE PACKAGE

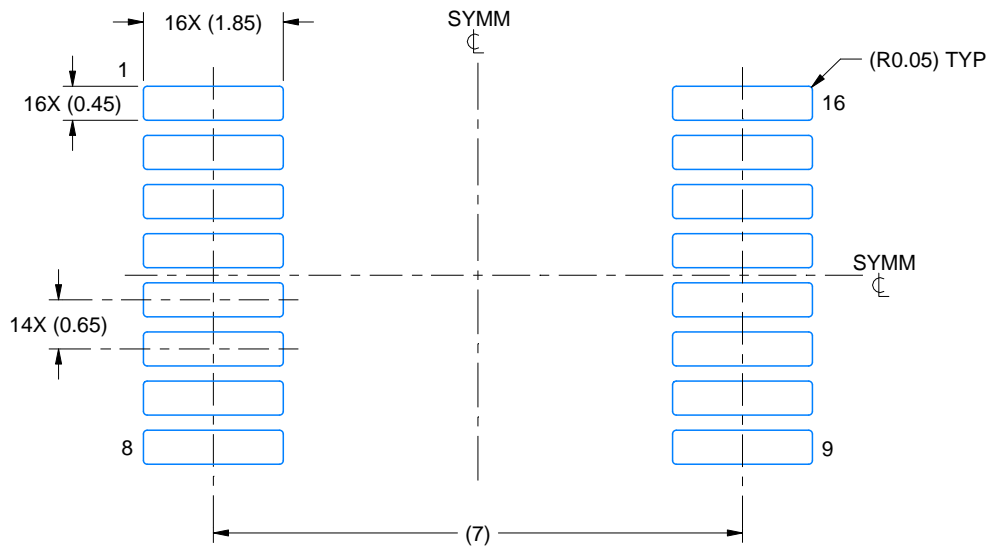

LAND PATTERN EXAMPLE  
EXPOSED METAL SHOWN  
SCALE: 10X

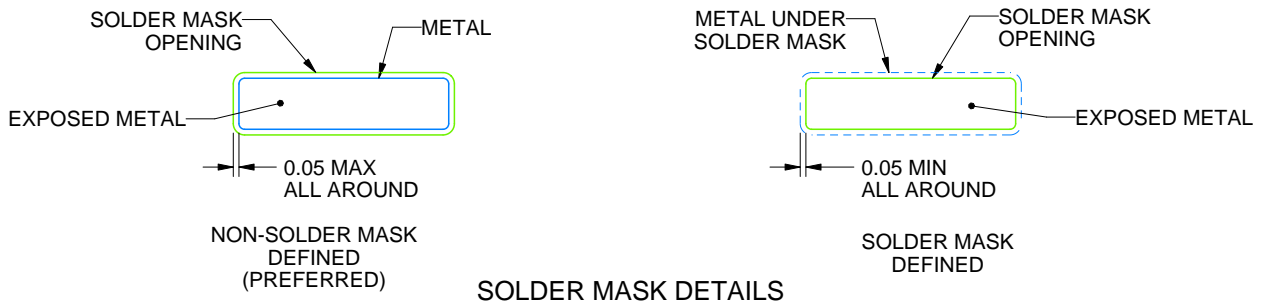

4220763/A 05/2022

NOTES: (continued)

- 5. Publication IPC-7351 may have alternate designs.
- 6. Solder mask tolerances between and around signal pads can vary based on board fabrication site.

# EXAMPLE STENCIL DESIGN

DB0016A

SSOP - 2 mm max height

SMALL OUTLINE PACKAGE

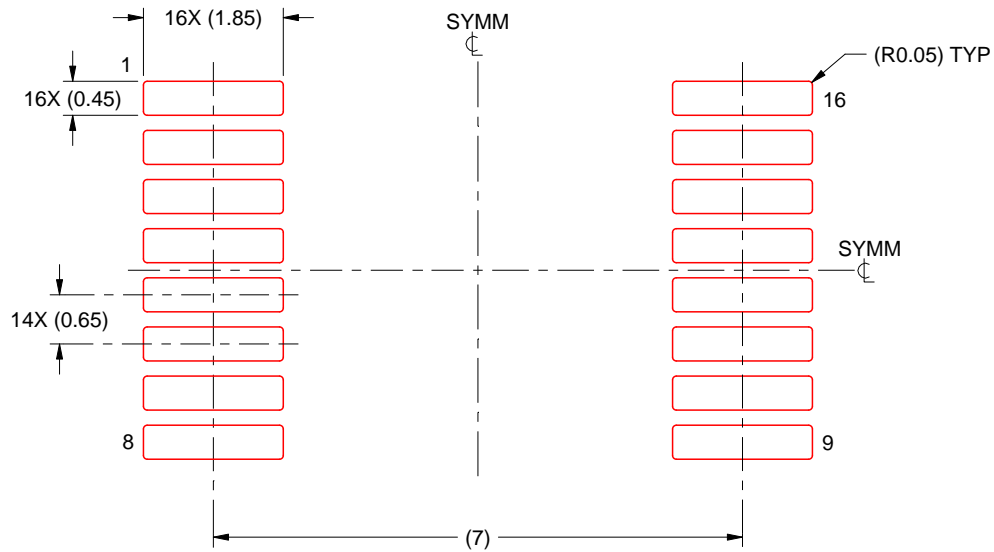

SOLDER PASTE EXAMPLE  
BASED ON 0.125 mm THICK STENCIL  
SCALE: 10X

4220763/A 05/2022

NOTES: (continued)

7. Laser cutting apertures with trapezoidal walls and rounded corners may offer better paste release. IPC-7525 may have alternate design recommendations.
8. Board assembly site may have different recommendations for stencil design.

# MECHANICAL DATA

NS (R-PDSO-G\*\*)

PLASTIC SMALL-OUTLINE PACKAGE

14-PINS SHOWN

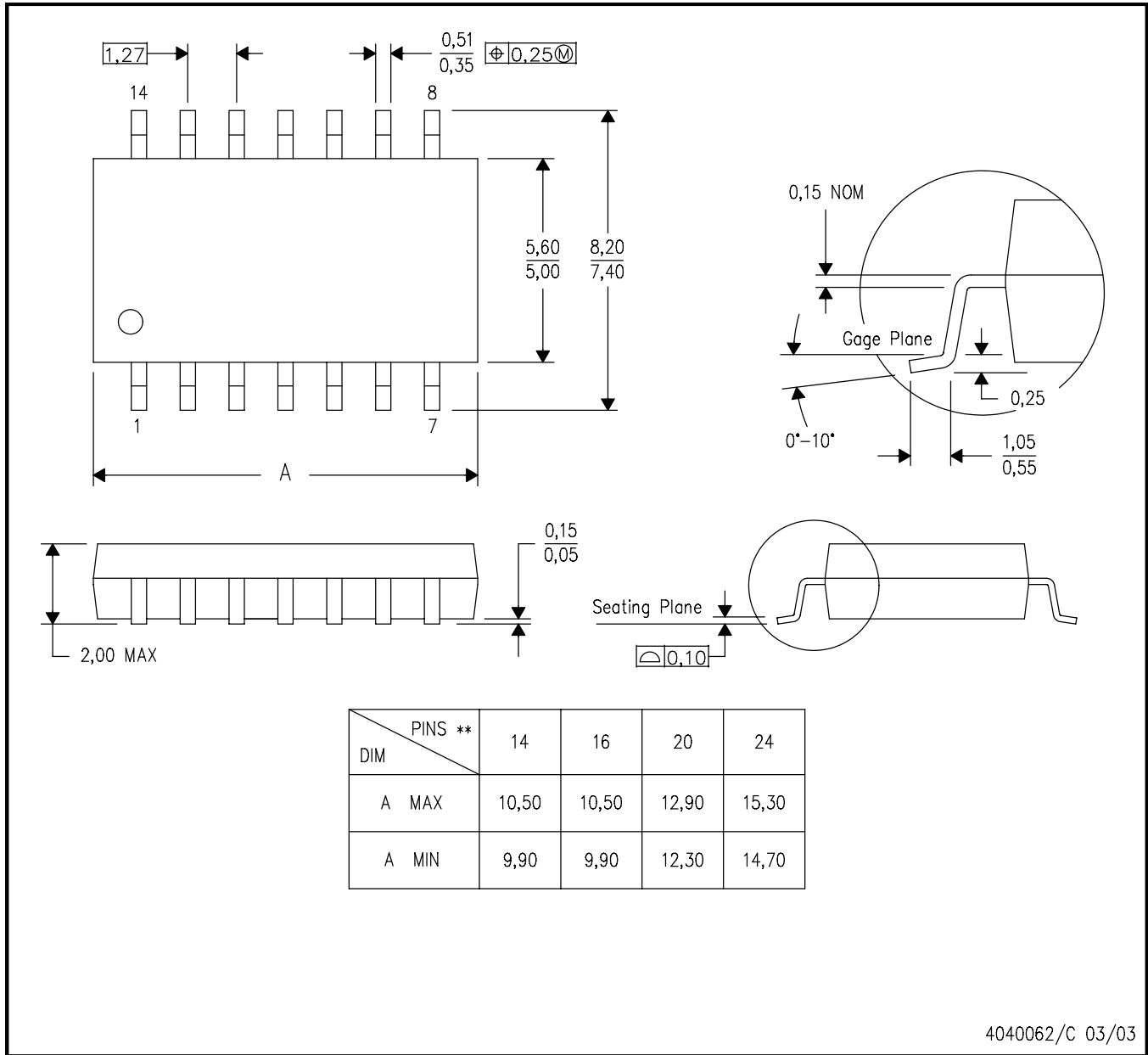

- NOTES:
- A. All linear dimensions are in millimeters.
  - B. This drawing is subject to change without notice.
  - C. Body dimensions do not include mold flash or protrusion, not to exceed 0,15.

## IMPORTANT NOTICE AND DISCLAIMER

TI PROVIDES TECHNICAL AND RELIABILITY DATA (INCLUDING DATA SHEETS), DESIGN RESOURCES (INCLUDING REFERENCE DESIGNS), APPLICATION OR OTHER DESIGN ADVICE, WEB TOOLS, SAFETY INFORMATION, AND OTHER RESOURCES "AS IS" AND WITH ALL FAULTS, AND DISCLAIMS ALL WARRANTIES, EXPRESS AND IMPLIED, INCLUDING WITHOUT LIMITATION ANY IMPLIED WARRANTIES OF MERCHANTABILITY, FITNESS FOR A PARTICULAR PURPOSE OR NON-INFRINGEMENT OF THIRD PARTY INTELLECTUAL PROPERTY RIGHTS.

These resources are intended for skilled developers designing with TI products. You are solely responsible for (1) selecting the appropriate TI products for your application, (2) designing, validating and testing your application, and (3) ensuring your application meets applicable standards, and any other safety, security, regulatory or other requirements.

These resources are subject to change without notice. TI grants you permission to use these resources only for development of an application that uses the TI products described in the resource. Other reproduction and display of these resources is prohibited. No license is granted to any other TI intellectual property right or to any third party intellectual property right. TI disclaims responsibility for, and you will fully indemnify TI and its representatives against, any claims, damages, costs, losses, and liabilities arising out of your use of these resources.

TI's products are provided subject to [TI's Terms of Sale](#) or other applicable terms available either on [ti.com](https://www.ti.com) or provided in conjunction with such TI products. TI's provision of these resources does not expand or otherwise alter TI's applicable warranties or warranty disclaimers for TI products.

TI objects to and rejects any additional or different terms you may have proposed.

Mailing Address: Texas Instruments, Post Office Box 655303, Dallas, Texas 75265

Copyright © 2025, Texas Instruments Incorporated